



Safety Precautions



Thank you for purchasing Shihlin Electric product. This user manual introduce how to install, wiring, inspect and operate Shihlin Servo Drive and Motor. Please read related items in this user manual prior to installation for safety.

- There are 2 safety notification levels in this user manual: Danger and Caution.

 DANGER	It indicates that it may cause severe or fatal injuries if the instructions are not followed.
 CAUTION	It indicates that it may cause moderate injury or malfunction of the product if the instructions are not followed.

Besides, for those items remark as CAUTION, it may cause bad consequences in some cases, please follow the instruction to operate due to its importance.

- Below symbols indicate the items should be followed.

	It indicates the FORBIDDEN items.
	It Indicates the MANDATORY Items.

In this user manual, NOTE indicates the cautions which may not cause malfunction of the product, but need pay attention.

Please read this manual carefully and keep it properly to make sure the user can reach it freely.

Safety Instruction

1. Electric Shock Prevention



- ⊘ Do NOT operate the switch with wet hands, otherwise it may cause electric shock.
- ⚠ Any wiring or inspection must perform AFTER turning off the power for over 20 minutes, charging indicator is off and voltage test is confirmed, otherwise it may cause electric shock.
- ⚠ Well ground the servo drive and motor.
- ⚠ Install the servo driver and servo motor before wiring, otherwise it may cause electric shock.
- ⊘ Do NOT damage the cable, apply excessive pressure, place heavy objects or extrude the cable, otherwise it may cause electric shock.
- ⊘ Do not disassemble the servo drive front cover when the power is on or under operation, otherwise it may cause electric shock.
- ⊘ Do NOT run the equipment when the servo drive front cover is disassembled, otherwise exposed the high voltage terminal and charging pins may cause electric shock.
- ⊘ Except for wiring and regular inspection, do NOT open the servo front cover, even if the power has been turned off, due to a charge may still remain in the components, which may cause electric shock.
- ⚠ Make sure that ground the servo drive protection grounding (PE) terminal (with  remark) on the protection grounding terminal (PE) of protection chamber.
- ⚠ Insulate the electrical terminal connection area to avoid electric shock.

2. Fire Disaster Prevention



- ⚠ Do NOT place the servo drive, motor or external regenerative resistor on or nearby

inflammable objects, otherwise, fire disaster may be caused.

- ❗ Turn off the servo drive power when problem occurs, otherwise, the high current flow may cause fire disaster.
- ❗ Turn off the power by regenerative abnormal signal When regenerative resistor is used. If there is a regenerative brake transistor fault, which will make the regenerative resistor overheat and may cause fire disaster.
- ⊘ Never let below items go inside of the servo drive or motor. Including: flammable matter, such as oil, fat, etc. And conductive matter: such as screw, metal parts, etc.
- ❗ Ensure the servo drive power supply is connected with a no-fuse breaker.

3. Injury Prevention



- ⊘ Do NOT apply voltages other than those specified in the specifications to each terminal, otherwise, a burst or damage may occur.
- ⊘ Do NOT make mistake when wiring to the terminal. Otherwise, a burst or damage may occur.
- ⊘ Do NOT make mistake on the(+ -)polarity. otherwise, a burst or damage may occur.
- ⊘ Do NOT touch the heat sink, regenerative resistor of the servo drive, servo motor and other components during operation or soon after the power just turned off, because it may get hot and cause injury.

4. Other cautions

Please pay attention to below notifications, improper operation may cause breakdown, injury , electric shock, etc.

(1) Delivery & Installation



- ⚠ Choose correct way to deliver the product base on its weight.
- ⊘ Never stack products which is beyond limitation.
- ⚠ Do NOT hand carry the cable, motor shaft, and encoder when deliver the servo motor.
- ⚠ Servo drive and motor must be installed on the location with enough bearing capacity.
- ⊘ Do NOT stand or put heavy staff on the product.
- ⚠ Ensure the product is installed correctly as specified in this manual.
- ⚠ Inside the protective chamber, a specified space must be reserved between the servo drive and other equipment.
- ⊘ Do NOT install, run the damaged or component missing servo drive and servo motor.
- ⊘ Do NOT congest the vent of servo drive. Otherwise, it may cause a malfunction.
- ⊘ Do NOT drop or strike the servo drive and servo motor as they are precision machinery.
- ⚠ Consult with Shihlin Electric system service representative if you need keep the product for a long period without using.

(2) Wiring



- ⚠ Do wiring carefully, otherwise, it may cause error on servo motor.
- ⊘ Do NOT install phase-in capacitors, surge absorber, and EMI noise filters between the servo drive and servo motor.
- ⚠ Connect the servo drive and motor correctly(terminal U,V,W), otherwise, it may cause malfunction of servo motor.
- ⊘ Connect the servo drive output(terminal U,V,W)and servo motor input(terminal U, V, W)

directly, Do NOT connect them by electromagnetic contactor, otherwise, it may cause abnormality or fault.

⊘ Do NOT put the diode which control the output signal in wrong direction. Otherwise, it may cause malfunction: no signal output and protect circuit is disabled.

⚠ Fasten the cable which is connect to the terminal panel with correct torque force. Otherwise, it may cause overheat on the cable and terminal panel.

(3) Trial run and adjustment.



⚠ Check the program and parameters before operation. Otherwise, it may lead to malfunction of the machine.

⚠ Do NOT adjust the parameter settings excessively, otherwise, it may cause some abnormal on the product.

(4) Operation



⚠ Set an emergency stop circuit outside the drive, which can be activated immediately in urgent cases to turn off the power supply.

⊘ Do NOT disassembly, repair or modify the equipment.

⚠ Please confirm that the run signal is off before clear the alarm. otherwise the motor might restart immediately and you may get injured.

⚠ Use noise filter to minimize the influence of electromagnetic interference, otherwise, the electric device nearby might be impacted.

⊘ Do NOT burn or disassemble the servo drive, or it may cause hazardous gas.

⚠ Ensure a specified combination of servo drive and motor is used.

⊘ The built-in electromagnetic brake is designed to hold the motor shaft, do NOT use for ordinary braking.

(5) Maintenance and Inspection



⚠ Ensure the power LED indicator is off before maintenance or inspection.

⊘ Only qualified electricians can install, wire, repair and maintain the servo drive and servo motor.

⚠ Do NOT disassemble the servo motor, otherwise you may get electric shock or injured.

⚠ When the power is ON, do NOT connect or disconnect the servo drive with motor.

⊘ The built-in electromagnetic brake is designed to hold the motor shaft, do NOT use for ordinary braking.

Note: The content of this manual may be revised without prior notice. Please consult our distributors or download the latest version at <http://www.seec.com.tw/en/>

1. Product Overview and Introduction	14
1.1 Outline.....	14
1.2 Product Checklist	14
1.3 Product Model Overview	15
1.3.1 Servo Motor Model Naming Rule.....	15
1.3.2 Servo Drive Model Naming Rule	18
1.3.3 Servo Drive and Motor Model Overview Chart	20
1.4 Servo Drive Appearance and panel Introduction.....	21
1.5 Servo Drive Control Mode Introduction	23
1.6 Recommended Specification Chart for Breaker and Fuse	24
2. Installation	24
2.1 Precautions and Storage.....	24
2.2 Installation Environment	25
2.3 Installation Direction and Clearances	25
3. Wiring and Signal	29
3.1 Connection of power supply and peripheral equipment.....	29
3.1.1 Peripheral equipment wiring diagram - Below 1KW.....	29
3.1.2 Peripheral equipment wiring diagram-1. 5KW~3KW	30
3.1.3 Description of Drive Connector and Terminals	30
3.1.4 Wiring for Power Supply	32
3.1.5 Connector specifications of motor U,V, W	33
3.1.6 Wire selection	34
3.2 CN1 I/O signal wiring and introduction	35
3.2.1 CN1 terminal configuration diagram	35
3.2.2 CN1 Signal Wire Shielding and Grounding.....	39

3.2.3 CN1 Terminal signal description	41
3.2.4 Interface wiring diagram	60
3.2.5 User-specified DI and DO signals.....	65
3.3 CN2 encoder signal wiring and description	66
3.3.1 Encoder lead wire connector specifications	67
3.4 CN3/CN3L communication port wiring and description	68
3.5 CN4 USB communication port.....	69
3.6 CN5 absolute encode battery connector.	70
3.7 Standard wiring instruction	71
3.7.1 Position control mode(Pr Mode) wiring diagram	72
3.7.2 Position control mode(Pt Mode) wiring diagram	73
3.7.3 Speed control mode (S Mode)wiring diagram.....	74
3.7.4 Torque control mode wiring diagram (T Mode)	75
4. Panel display and operation.....	76
4.1 Name of each part of the panel	76
4.2 Displayed procedure	77
4.3 Status display	78
4.4 One-touch Tuning Function	84
4.5 Alarm mode	84
4.6 Diagnostic mode.....	86
4.6.1 External I/O signal indicator.	87
4.6.2 Forced output (DO forced output)	89
4.6.3 JOG operation	90
4.6.4 Test positioning operation.....	92
4.6.5 Inertia estimation and tuning by communication software	92

4.7 Parameter mode.....	96
4.7.1 16 bit parameter setting instruction.....	96
4.7.2 32 bit parameter setting instruction.....	97
5. Running Operation.....	100
5.1 Check items Before Operation.	100
5.2 No-load test.....	101
5.2.1 No-load JOG test.....	101
5.2.2 No-load positioning test.....	104
5.3 Tuning procedure.	106
5.3.1 Tuning method and type.....	106
5.3.2 One-touch Tuning Function.....	109
5.3.3 Auto tuning function.....	117
5.3.4 Manually tuning mode.....	122
5.3.5 Interpolation mode.....	124
5.4 Position mode parameter setting and operation.....	125
5.5 Speed mode parameter setting and operation.	127
5.6 Torque mode parameter setting and operation.....	130
6. Control function.....	132
6.1 Control mode option.....	132
6.2 Torque control mode.....	134
6.2.1 Torque command.....	134
6.2.2 Torque command smoothing.....	135
6.2.3 Torque limit of torque control mode.....	135
6.2.4 The speed limit of torque mode.....	137
6.3 Speed control mode.....	139

6.3.1 Selection of speed command	140
6.3.2 Speed command Smoothing	141
6.3.3 Torque limit of speed control mode.....	144
6.3.4 Adjustment of speed loop gain	145
6.3.5 Resonance suppression unit	148
6.3.6 Gain switch function.....	154
6.4 Position control mode.....	161
6.4.1 External pulse command(Pt command).....	162
6.4.2 Internal position command (Pr command)	165
6.4.3 Position command smoothing.....	166
6.4.4 Electronic gear.....	168
6.4.5 Torque limit of position loop.....	170
6.4.6 Position loop gain.	170
6.5 Dual control mode.	171
6.5.1 Position/speed dual mode	173
6.5.2 Speed/torque dual mode	174
6.5.3 Torque/position dual mode.	175
6.6 Other functions	176
6.6.1 Selection of regenerative resistor	176
6.6.2 Operation of electromagnetic brake.....	181
7. PR (procedure) sequence control introductions	183
7.1 PR introduction.....	183
7.2 DI/DO and sequences	183
7.3 Parameter setting of PR.....	185
7.4 PR sequence status	196

8. Parameter setting	201
8.1 Parameter definitions	201
8.2 List of Parameters	203
8.3 Parameter group introduction	229
Table 8.1: Digital input(DI) function description:	311
Table 8.2: Digital output(DO) function description.	312
9. Communication function	314
9.1 Communication hardware interface and wiring	314
9.2 Communication specifications	316
9.3 Modbus communication protocol.....	317
9.3.1. ASCII mode	317
9.3.2. RTU mode	325
9.4 Setting and accessing communication parameters	332
10. Troubleshooting	346
10.1 Alarm list and corrective actions.....	346
10.2 Causes and corrective actions	349
11. Specifications	364
11.1 Servo drive standard specifications.....	364
11.2 Interface and out dimensions of the servo drive	366
11.3 Dimensions of the servo drive	367
11.4 SME series servo motor general specification.....	368
11.4.1 Standard Specification of Low Capacity Servo Motor.....	368
11.5 Motor dimensions	370
11.5.1 Dimensions of 3000 RPM motor.....	370
11.5.2 Dimensions of 2000 RPM motor.....	371

11.5.3	Dimensions of servo motor keyway	371
11.6	Electromagnetic Interference Filter (EMI Filter)	372
11.7	EMI interference countermeasure	373
12.	Features	375
12.1	Motor T-N Curve/S-T curve	375
12.2	Overload features	377
13.	Absolute Servo System	379
13.1	Mitsubishi Absolute Position Detection System	383
13.1.1	Signal description	383
13.1.2	Startup procedure	384
13.1.3	Absolute position data transmission protocol	385
13.2	Delta absolute position detection system	395
13.2.1	Signal description	395
13.2.2	Start procedure	396
13.2.3	Use DI/DO to initialize absolute coordinates	397
13.2.4	Use parameter settings to initialize absolute coordinates	398
13.2.5	Absolute position data transmission protocol	399
13.3	Absolute battery specifications	401
14.	Appendix	403
14.1	Accessories	403
14.2	Regenerative resistor	408
14.3	Table of communication address	409
14.4	Compliance with global standards	414
14.4.1.	Safety instructions	414
14.4.2.	Professional technicians	414

14.4.3. Compliance with standards	414
14.4.4. Correct use method	415
14.4.5. Basic inspection and maintenance	417
14.5 Manual version and revision history	419

1. Product Overview and Introduction

1.1 Outline

The control modes of Shihlin general purpose AC servo includes single mode and dual mode. Single mode includes following 4 types: position mode(terminal input), position mode(internal register), speed mode and torque mode. And dual mode includes following 5 types: position mode(terminal input)/speed mode, position mode(terminal input)/torque mode, position mode(internal register)/speed mode, position mode(internal register)/torque mode, speed mode/torque mode.

The servo can be used for high-precision positioning system, speed control smoothing system in general machinery industry, machine tools and tension control system.

Shihlin servo have RS-485 series communication function, and also have the most convenient USB communication function, this enable that you can rapidly perform parameter adjustment, test operation, status monitoring and gain adjustment by a computer which is installed with Shihlin communication software.

With the auto tuning function, Shihlin servo gain value could automatically adjust according to the machinery status. The Shihlin series servo is equipped with 17-bit pulses/rev absolute magnetic encoder, it can perform high-precision control.

1.2 Product Checklist

Check below items before you start to use our product:

- ◆ Any loose or fall off screw on motor or drive.
- ◆ Check if the product model name on nameplates of the motor and drive are align with the purchase order. You can refer to the product model list in next section.
- ◆ Check if any damage or scratch on the surface of the motor and drive.
- ◆ Manually rotate the motor shaft to check if it can move smoothly to make sure no abnormality on the motor shaft. If the motor is equipped with electromagnetic brake, you cannot smoothly rotate the motor shaft by hand.

If any of the above problems occur, please contact the distributor.

A complete servo set includes:

- (1) A servo drive and a servo motor.
- (2) A UVW motor power cable: one end of the U, V, and W wires connects to the corresponding terminal panel and the other end to the UVW connector on the motor. The green wire is connect to the ground terminal of the servo drive (optional purchase).
- (3) An encoder cable: one end of it connects to the CN2 of the servo drive and the other end to encoder.
- (4) A USB communication cable, one end of it connects to CN4 on the drive, the other end to USB port on the computer. (Optional purchase).
- (5) A 50 Pin connector for CN1.
- (6) A 8 Pin connector (L1, L2, P, C, N, U, V, W) for servo below 1kw.
- (7) An installation guide.
- (8) A Shihlin servo user manual, the electric copy can be download from the website.

1.3 Product Model Overview

1.3.1 Servo Motor Model Naming Rule

1. Naming Rule

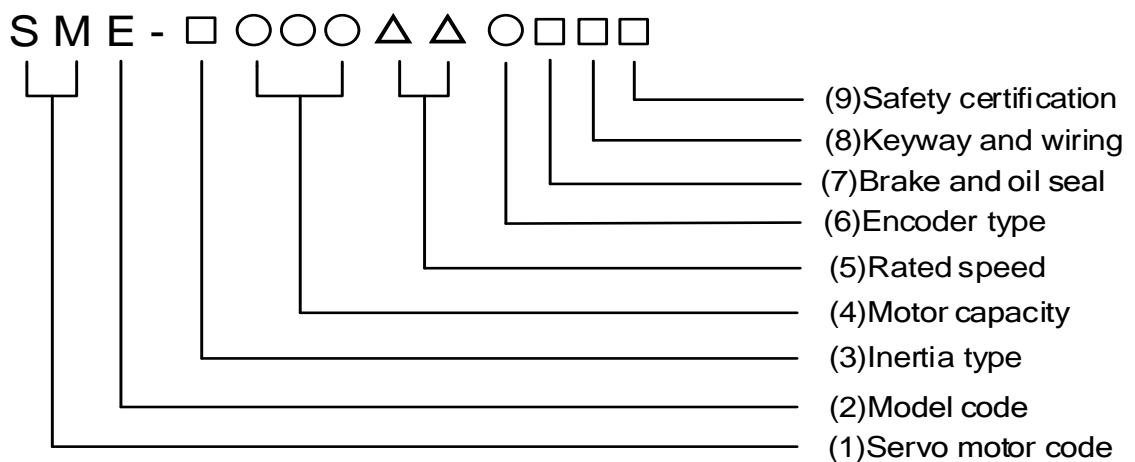

2. Description of each code item.

(1) Servo motor code: SM indicates servo motor.

(2) Model code: E.

(3) Inertia classification: Coding according to the motor inertia as follows:

Code	Inertia class
L	Low
M	Medium (SDC currently not supported)
H	High(SDC currently not supported)

(4) Motor capacity: motor output power.

Code	010	020	040	075	100
Motor power(W)	100	200	400	750	1000

(5) Rated speed: the rated output speed of motor.

Code	20	30
Rated speed(rpm)	2000	3000

(6) Encoder type: Shihlin servo motor magnetic encoder(17bit)
Shihlin servo motor optical encoder(22bit)

Code	Encoder type
T	Single turn, 17bit/rev
N	65536 turns, 17bit/rev
S	Single turn, 22bit/rev
M	65536 turns, 22bit/rev

(7) Brake and oil seal: below codes to indicate whether the motor is equipped with brake and oil seal.

Item \ Code	A	B	C	D
	Brake	—	●	—
Oil seal	—	—	●	●

(8) Keyway and outlet type: below codes to indicate if the motor have keyway and outlet type selection.

Code \ Item	A	B	C	D
Keyway	—	•	—	•
back side cable	—	—	•	•

(9) Safety certification: the certified safety certification of the motor is indicated by the following code:

Code \ Item	CE Certification	Conform to UL/CE certification
Code	-	U

Code samples:

Example (1): 200W motor, low inertia, rated speed 3000 rpm, no brake, no oil seal, no keyway, Single-turn absolute magnetic type encoder, with CE certification, the model name is as follows: SME-L02030TAA.

Example (2): 750W motor, low inertia, rated speed 3000 rpm, with brake, no oil seal, with keyway, Multi-turn absolute magnetic type encoder, rear lead wire, with UL certification, the model name is as follows: SME – L07530NBDU.

Example (3): 1000W motor, low inertia, rated speed 3000 rpm, no brake, oil seal, with keyway, Multi-turn absolute magnetic type encoder, with CE certification, the model name is as follows: SME – L10030NCB.

1.3.2 Servo Drive Model Naming Rule

1. Naming Rule

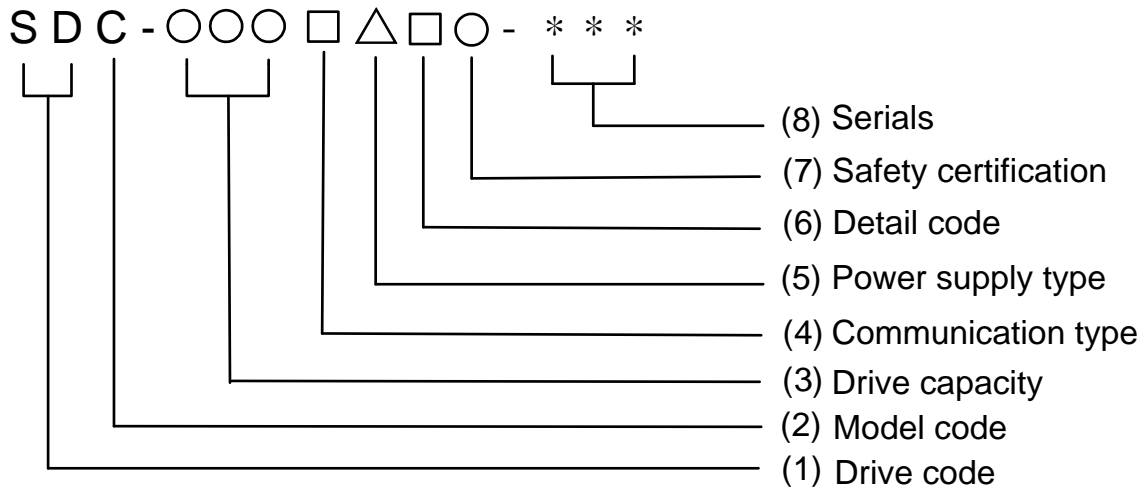

2. Description of each code item

(1) Drive code: SD means servo drive.

(2) Model code: C.

(3) Drive capacity: motor output capacity, it indicate by the last 3 digits

of the number which is a multiply the motor output power with 1/10. For models above 1000W, using the English letter K in the third code to represent 1000W,

Example: 020 means 200W; 100 means 1000W.

(4) Communication type: different types of communication

Code	A	C	E
Item			
Communication protocol	Modbus	CANopen	EtherCAT

(5) Power type: input power specification

2: Single-phase or three-phase, 220VAC

4: Single-phase or three-phase, 440VAC

(6) Detail code

Code	-	A	C
Item			
Application type	General		Full-closed

(7) Safety certification: the certified safety certification of the drive is indicated by the following code.

Code	CE certification	Conform the UL/CE certification
Item		
Code	-	U

(8) Series

Code	General type	Advanced type	SXX
Item			
Code	-	P	Customer type or Other definitions

Example description:

Example (1): For a 200W drive, with CE certification, single-phase or three-phase 200~240VAC, general type, the coding is as follows: SDC – 020A2.

Example (2): For a 400W drive, with UL certification, single-phase or three-phase 200~240VAC, general type, dedicated for a certain customer, The code is: SDC-040A2-UXX, in which XX is a number.

1.3.3 Servo Drive and Motor Model Overview Chart

	Servo Drive	Corresponding servo motor
100W	SDC-010A2□○-***	SME-L01030○□□□
200W	SDC-020A2□○-***	SME-L02030○□□□
400W	SDC-040A2□○-***	SME-L04030○□□□
750W	SDC-075A2□○-***	SME-L07530○□□□
1000W	SDC-100A2□○-***	SME-L10030○□□□

Note 1; □ is safety certification, *** is Shihlin definition/market/customer.

Note 2: ○ is encoder type of servo motor. ○=T is for single turn resolution type, ○=N is multi-turn resolution type.

Note 3: For the description of □□□ in the servo motor, please refer to section 1.3.1.

1.4 Servo Drive Appearance and panel Introduction

1.4.1 Appearance and panel of Drive below 1kw

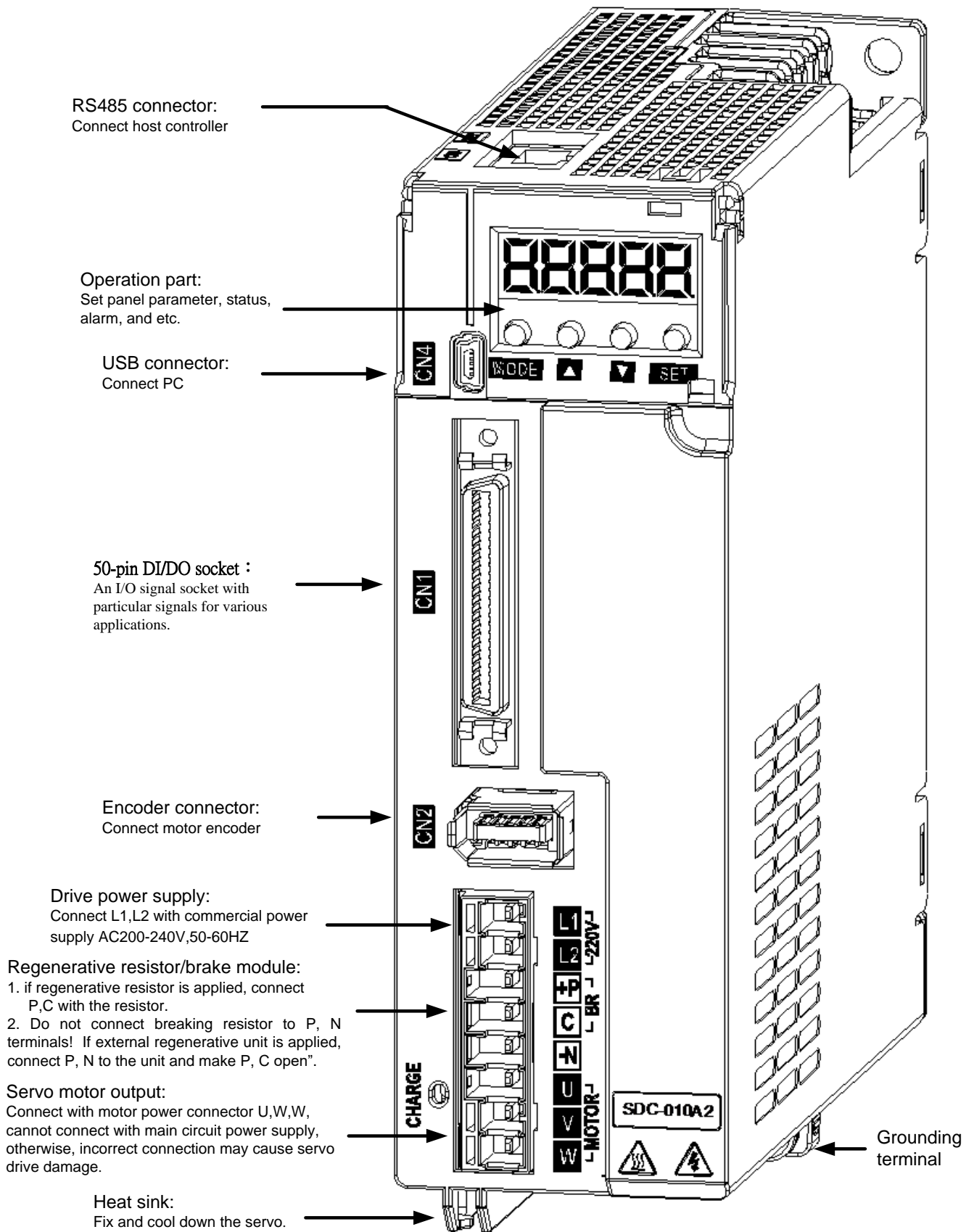

1.5 Servo Drive Control Mode Introduction

Shihlin servo drive provides a variety of control modes for you, as detailed in the table below:

Mode Name		Mode code	Description
Single Mode	Position mode(terminal input)	Pt	Drive receives the external position pulse command which is input from terminal , then runs the motor to reach the target position.
	Position mode(internal register)	Pr	The drive receives the position command which is provided by the internal register (64 groups of registers). and runs the motor to the target position. The DI signal can be used to select the register number.
	Speed mode	S	The drive receives the speed command and runs the motor to the target speed. The speed command can be selected by the DI signal(7 groups of register)
	Torque mode	T	The drive receives torque command which is provided by three groups of internal torque commands and runs the motor to the target torque.
Dual mode		Pt-S	Pt/S is switched mutually via the signal of DI.
		Pt-T	Pt/T is switched mutually via the signal of DI.
		Pr-S	Pr/S is switched mutually via the signal of DI.
		Pr-T	Pr/T is switched mutually via the signal of DI.
		S-T	S/T is switched mutually via the signal of DI.

- ★ You can set PA01 to perform the mode selection. After PA01 is been set, you should restart the power to activate it.
- ★ If use the default configuration directly, the Parameter PA01 need set as 1XXX.

1.6 Recommended Specification Chart for Breaker and Fuse

Specification of Shihlin Servo Drive Fuse and Breaker

Drive Model Name	Fuse	Circuit Breaker
SDC-010A2□	5A	5A
SDC-020A2□	5A	5A
SDC-040A2□	20A	10A
SDC-075A2□	20A	10A
SDC-100A2□	25A	15A

2. Installation

2.1 Precautions and Storage

- ◆ Do not install the product in the location with or nearby inflammable matters.
- ◆ Do not over tighten the wire between the drive and the motor.
- ◆ Do not place heavy objects on the top of the drive.
- ◆ Be sure to fasten every screw tightly when fixing the drive.
- ◆ Install the drive at a location with proper weight capacity.
- ◆ The motor shaft must be aligned with the shaft of the equipment.
- ◆ Do not mix metal pieces, screws and other conductive matters or inflammable matters such as oil in the drive.
- ◆ Upgrade the diameter of the U/V/W wires and the encoder cable if the length between the drive and the motor is over 20meters.
- ◆ Do NOT congest vent of the drive, otherwise breakdown may be occurred.
- ◆ Do not drop or strike the drive.

- ◆ Do not try to operate the drive if something has been damaged.
- ◆ Refer to section 10.1 and 11.3 for drive and motor storage details.

2.2 Installation Environment

The applicable ambient temperature for Shihlin drive is between 0°C and 55°C. If it exceeds 45°C, please place the drive in a well-ventilated or air-conditioned room. It is recommended to keep the ambient temperature below 45°C for long-term operation to ensure the reliable performance of the product. If this product is installed in a distribution box, the size of the distribution box and the ventilation conditions must be good enough to ensure that all internal electronic devices are free from the danger of overheating, and be careful if vibration of the machine will impact the electronic devices of the distribution box.

In addition, the applicable location of Shihlin servo includes the following criteria:

- ◆ Locations without high-heating devices.
- ◆ Locations without floating dust and metal particles.
- ◆ Locations without corrosive, inflammable gas and liquid.
- ◆ Locations without water drops, steam, dust or oil dust.
- ◆ Locations without electromagnetic noise interference.
- ◆ Select a solid, vibration-free location.

2.3 Installation Direction and Clearances

Cautions:

The installation direction must follow the requirement, otherwise it may cause servo breakdown. When installing Shihlin AC servo drive, sufficient clearance must be reserved between its surrounding and adjacent objects to ensure a good cooling air flow cycle. When installing the AC servo drive, its vent cannot be sealed or dumped, otherwise it may cause breakdown.

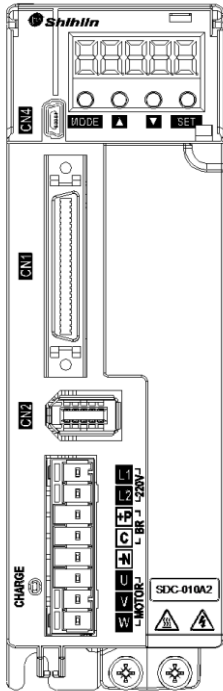

CORRECT

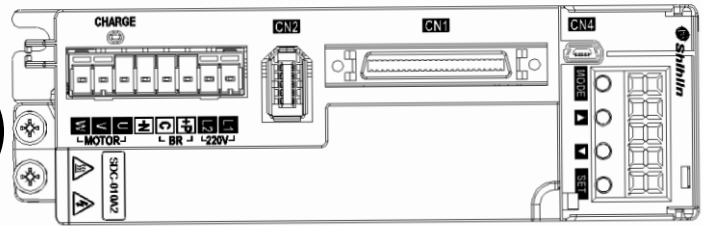

WRONG

Installation diagram:

In order to have adequate air flow for ventilation, please follow the suggested clearances when installing one or more servo drives (refer to the following diagrams).

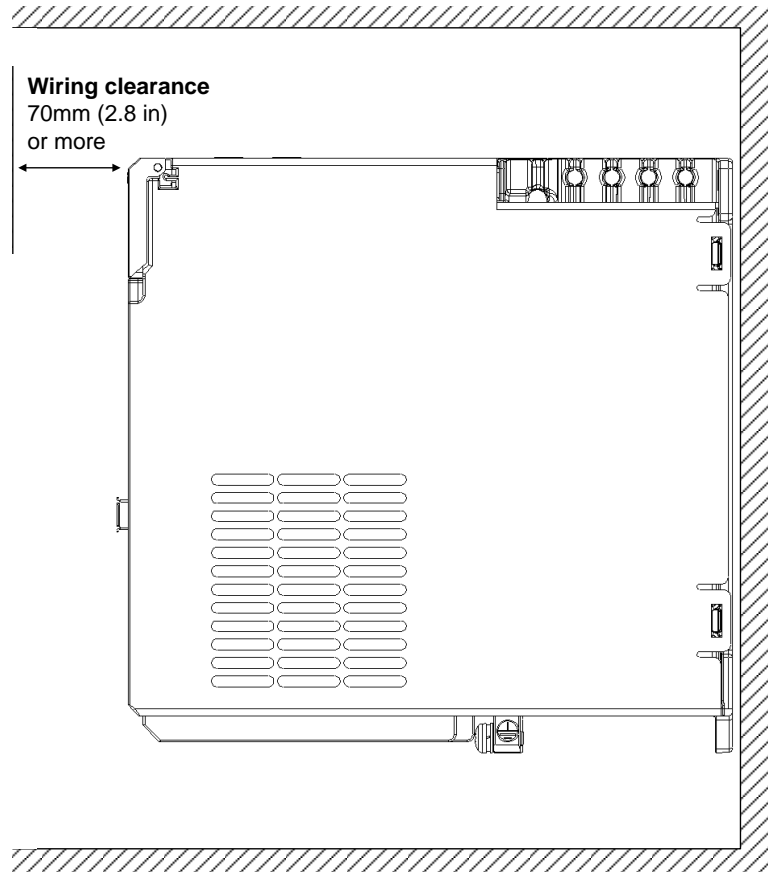
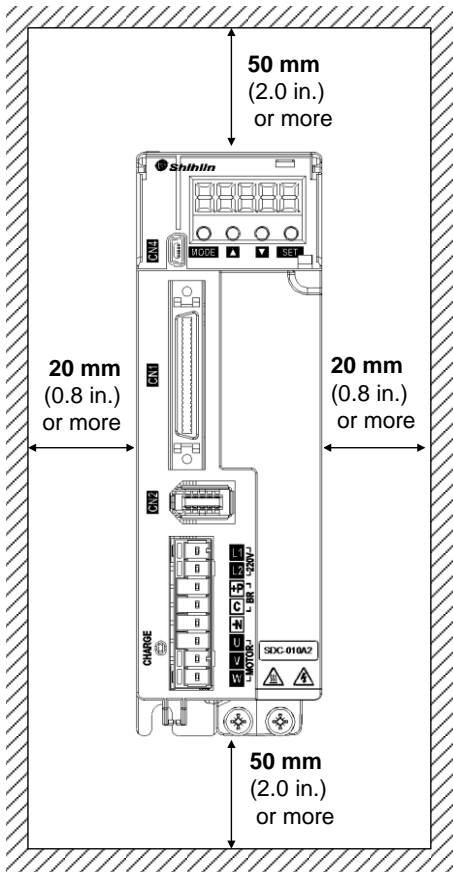

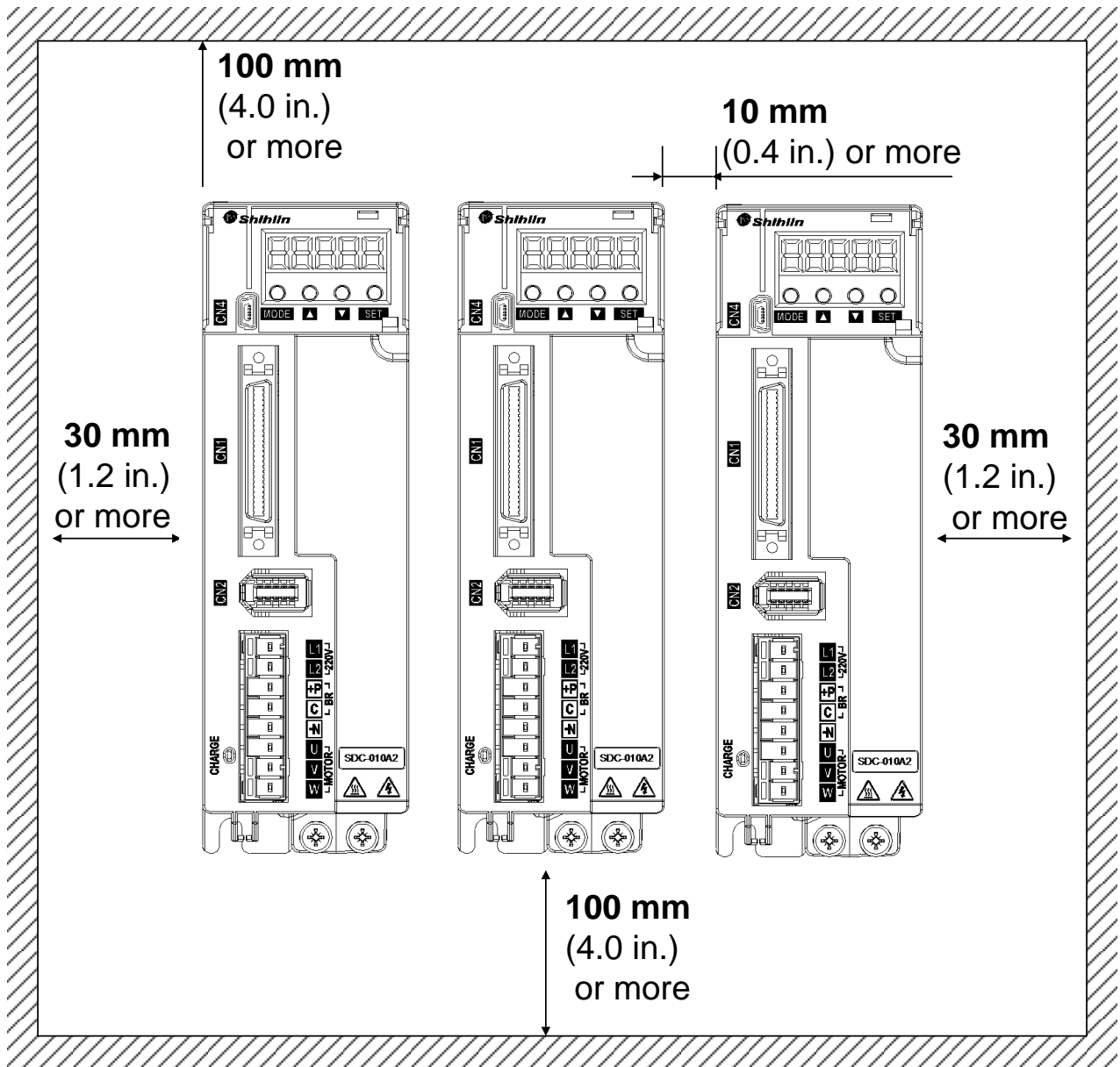

3. Wiring and Signal

This chapter explains the wiring method of Shihlin servo drive and the definition of signals, as well as the standard wiring diagrams in all modes.

3.1 Connection of power supply and peripheral equipment

3.1.1 Peripheral equipment wiring diagram - Below 1KW

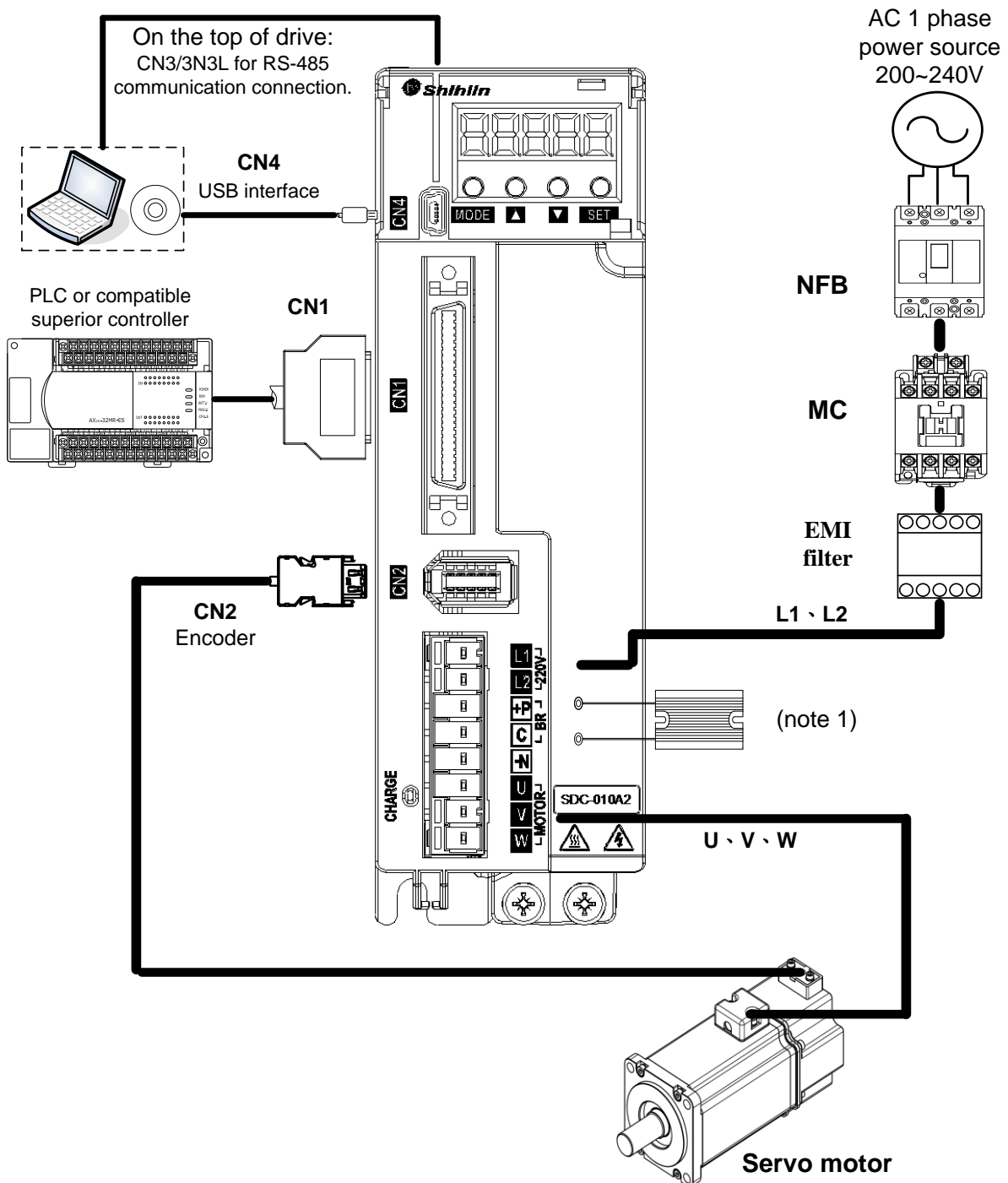

Note1: If an external brake resistor is applied, please make sure that “P” and “C” connect to the resistor, and make “P” and “N” open. If an active brake unit is applied, connect “P” and “N” to the unit and make “P” and “C” open. “Do not connect braking resistor to P, N terminals!”

※For detailed EMI filter content, please refer to section 12.6 EMI Filter



DANGER

Prevent electric shock, the ground protection (PE) terminal (marked terminal \oplus) of the servo drive must be connected to the ground protection terminal of the controller.

3.1.2 Peripheral equipment wiring diagram-1. 5KW~3KW

Content reserved due to no such capacity currently.

3.1.3 Description of Drive Connector and Terminals

Item	Terminal name	Description	
Power supply input	L1, L2	Connect to single-phase AC power source	
Motor power input terminal	U, V, W, PE	Terminal code	Wire color
		U	red
		V	white
		W	black
		PE	green
Regenerative resistor terminal	P, C	External resistor	Remove the original wiring and connect a regenerative resistor.
		Internal resistor	P and C terminals are connected to the internal regenerative resistor.

Grounding terminal		Connect both the power grounding terminal and the motor grounding terminal, which is the green screw on the outside of the controller.
P: Main circuit+ terminal N: Main circuit -terminal	P, N	When selecting to use a brake module, connect its + terminal to the P terminal of servo drive, and its - terminal to N terminal of servo drive. The brake module is optional purchase item and usually does not need to be connected. it is used to offset the regenerative energy when the huge regenerative power produced by the servo motor.
I/O connector	CN1	Connect to the host controller.
Encoder connector	CN2	Connect to the encoder.
RS-485 connector	CN3/CN3L	Connect to RS485 device.
USB connector	CN4	Connect to USB slot of PC.
Absolute encoder battery connecting terminal	CN5	Connect to absolute encode battery pack(optional purchase).

The following items must be paid special attention:

1. Separate L1, L2 and U, V, W from other wires. The separation should be at least 30 cm.
2. When the power supply is OFF, do not touch the power cable L1, L2 and U, V, W because the big capacitors inside the drive contains a large amount of electric charge. Wait for the charging indicator OFF before touching.
3. If the encoder wiring needs to be lengthened, use a twisted pair with an isolated grounded signal wire and it should not exceed 20 meters (65. 62 feet). If it exceed 20 meters, a signal cable that is twice the diameter must be used to ensure that the signal will not attenuated too much.
4. If the power supply and the detector (encoder) of the SV motor are not fixed on the motor, it may cause them swaying and poor wire contact.

3.1.4 Wiring for Power Supply



DANGER

- Insulate the connection of the power terminal to avoid the possibility of electric shock.



CAUTION

- The power supply wire(U · V · W) of the servo drive and the servo motor must be connected correctly to avoid any abnormal operation on servo motor.
- Servo motor cannot be connected to commercial power supply, otherwise it may cause malfunction.

The power wiring of Shihlin servo drive is a single-phase power supply. In this below figure, Power ON is A contact point, Power OFF and Alarm Processing are B contact points. 1MC/a is self-contained supply, and 1MC is electromagnetic contactor.

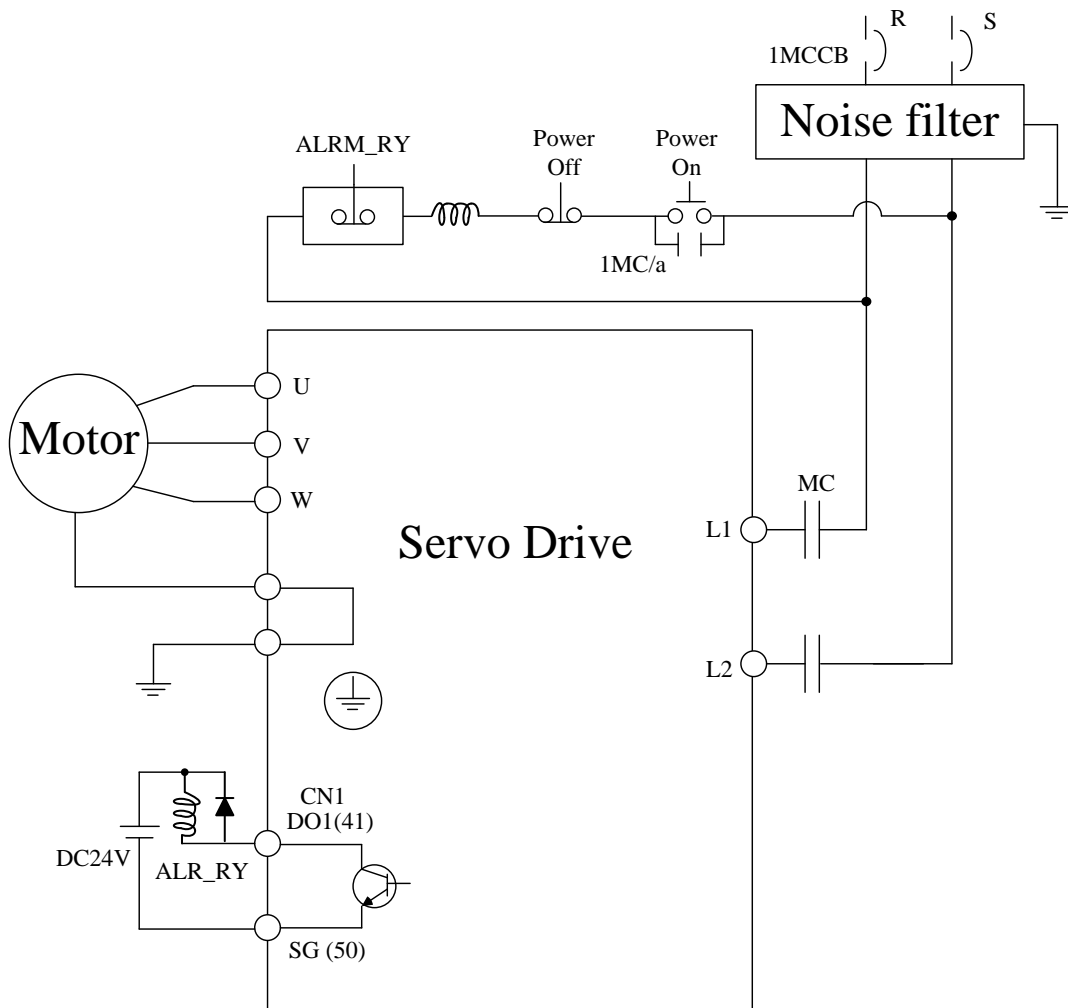

3.1.5 Connector specifications of motor U,V, W

Connector specifications of Shihlin low inertia motor U, V, W (female connector):

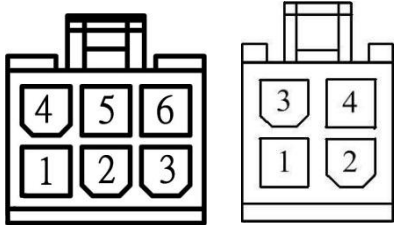
Drive capacity	Motor model	
100W	SME – L01030○□□□	 <p>The diagram shows two female connector terminal blocks. The 'With brake' block has six terminals labeled 1 through 6 in a 2x3 grid. The 'Without brake' block has four terminals labeled 1 through 4 in a 2x2 grid.</p>
200W	SME – L02030○□□□	
400W	SME – L04030○□□□	
750W	SME – L07530○□□□	
1kW	SME – L10030○□□□	

The following table shows the signal of low inertia motor UVW ends:

PIN	Signal	Wire color
1	U	red
2	V	white
3	W	black
4	PE	green/yellow(green is the bottom)
5	NC	black(for motor with electromagnetic brake)
6	NC	black(for motor with electromagnetic brake)

★ Note: the above wiring connects to the motor itself.

3.1.6 Wire selection

Drive model	Wire[mm ²]			
	Power supply wiring(AWG)			
	L1, L2	U, V, W	P, C, N	B1, B2
SDC-010A2□	2(AWG14)	2(AWG14)	2(AWG14)	2(AWG14)
SDC-020A2□				
SDC-040A2□				
SDC-075A2□				
SDC-100A2□				

Drive model	Encoder wiring(AWG)			
	Wire specification	Standard wire length	Wire count	Wire gauge
SDC-010A2□	UL1332	2meters	10	AWG26
SDC-020A2□	UL1332	2meters	10	AWG26
SDC-040A2□	UL1332	2meters	10	AWG26
SDC-075A2□	UL1332	2meters	10	AWG26
SDC-100A2□	UL1332	2meters	10	AWG26

- ★ Please wiring base on the recommended specifications or higher to avoid danger.
- ★ The shielding end of isolation net should be grounded.
- ★ Use twisted-pair isolated wires to reduce noise interference when wiring encoder.
- ★ American Wire Gauge (AWG) is US wire diameter standard.
- ★ The standard is to use 600V vinyl wire, and the wiring distance is less than 30meters.
- ★ If the wiring distance exceeds 30meters, please consider the voltage drop before changing the wire gauge.
- ★ Use UL-certified copper wires with a rating of 75°C or higher when wiring for UL/C-UL (CSA) specifications.
- ★ Ground wire needs to use AWG14, 12in-lbs.

3.2 CN1 I/O signal wiring and introduction

3.2.1 CN1 terminal configuration diagram

Shihlin servo drives provides user-defined 9 digital input (DI) points and 5 digital output (DO) points which enable a more flexible connection method between the servo drive and the host controller. The 9 user-defined input DIs are PD02~PD09 and PD21, and the 5 output DO are PD10~PD14. In addition, it provides differential output encoder A+, A-, B+, B-, Z+, Z- signals, its pin diagram is shown as follows:

(1) CN1 connector(female)

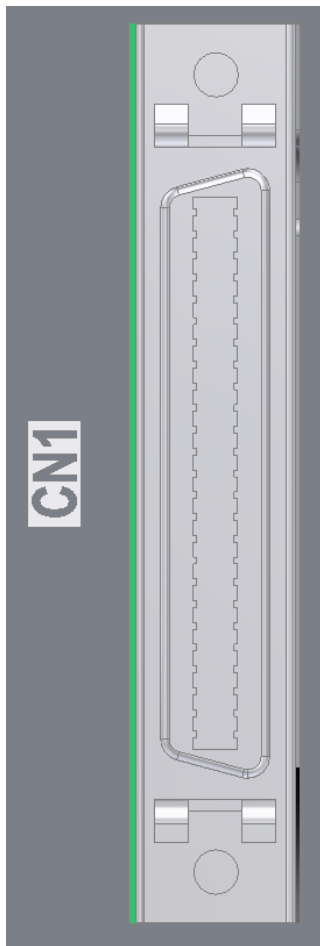

Front view

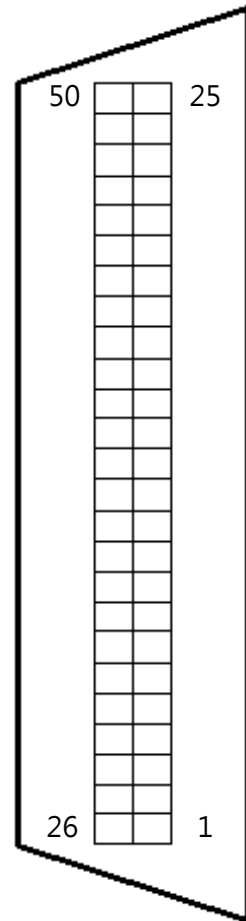

Pin assignment

(2) CN1 connector(male)

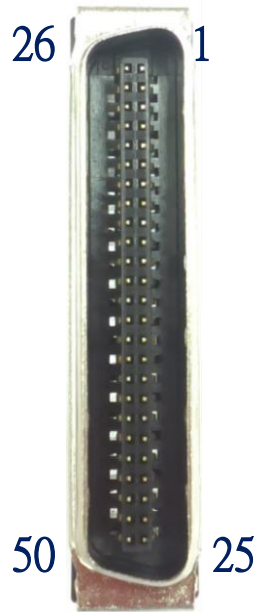

front view

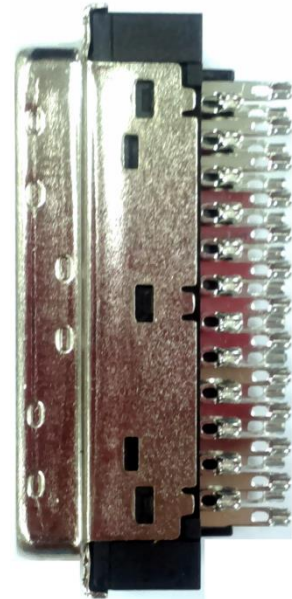

side view

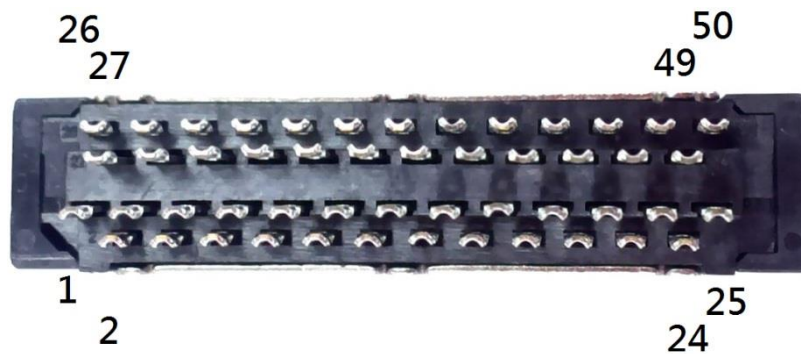

Rear view

26	NC	LG	NC	NC	/LAR	/LBR	/LZR	DOCOM	DO2	DO4	NC	VDD	SG	50
27	NC	LG	LG	LA	LB	LZ	OP	DO1	DO3	DO5	COM+	COM+	49	
1	NC	LG	NG	OPC	PG	NC	NC	DI2	DI4	DI6	DI8	NC	SG	25
2	NC	LG	NP	PP	NC	NC	DI1	DI3	DI5	DI7	DI9	SG	24	

CN1 terminal on the back of the connector

Pin	Code	Function	Pin	Code	Function	Pin	Code	Function	Pin	Code	Function
1	NC	NA	2	NC	NA	26	NC	NA	27	NC	NA
3	LG	Signal ground of OP	4	LG	Signal ground of OP	28	LG	Signal ground of OP	29	LG	Signal ground of OP
5	NG	Input pulse	6	NP	Input pulse	30	NC	NA	31	LG	Signal ground of OP
7	OPC	Open collector power input	8	PP	Input pulse	32	NC	NA	33	LA	Encoder A pulse output
9	PG	Input pulse	10	NC	NA	34	LAR	Encoder A pulse reverse output	35	LB	Encoder B pulse output
11	NC	NA	12	NC	NA	36	LBR	Encoder B pulse reverse output	37	LZ	Encoder Z pulse output
13	NC	NA	14	DI1	Digital input 1	38	LZR	Encoder Z pulse reverse output	39	OP	Encoder Z pulse output(Open-collector)

15	DI2	Digital input 2	16	DI3	Digital input 3	40	DOC OM	Common port of digital output	41	DO1	Digital output1
17	DI4	Digital input 4	18	DI5	Digital input 5	42	DO2	Digital output 2	43	DO3	Digital output 3
19	DI6	Digital input 6	20	DI7	Digital input 7	44	DO4	Digital output 4	45	DO5	Digital output 5
21	DI8	Digital input 8	22	DI9	Digital input 9	46	NC	NA	47	COM+	Digital input power
23	NC	NA	24	SG	Digital power ground	48	Vdd (24V)	+24V power output	49	COM+	Digital input power
25	SG	Digital power ground				50	SG	Digital power ground			

3.2.2 CN1 Signal Wire Shielding and Grounding

The both ends of the CN1 signal line which is the CN1 connector and the upper controller terminal, its shielding and grounding wire must be connected to the corresponding pins to effectively achieve the shielding and grounding functions.

Connecting shielded wire to the CN1 encoder connector as following instruction:

1. Pull out the metal isolation net and fix it with a copper sheet around it.

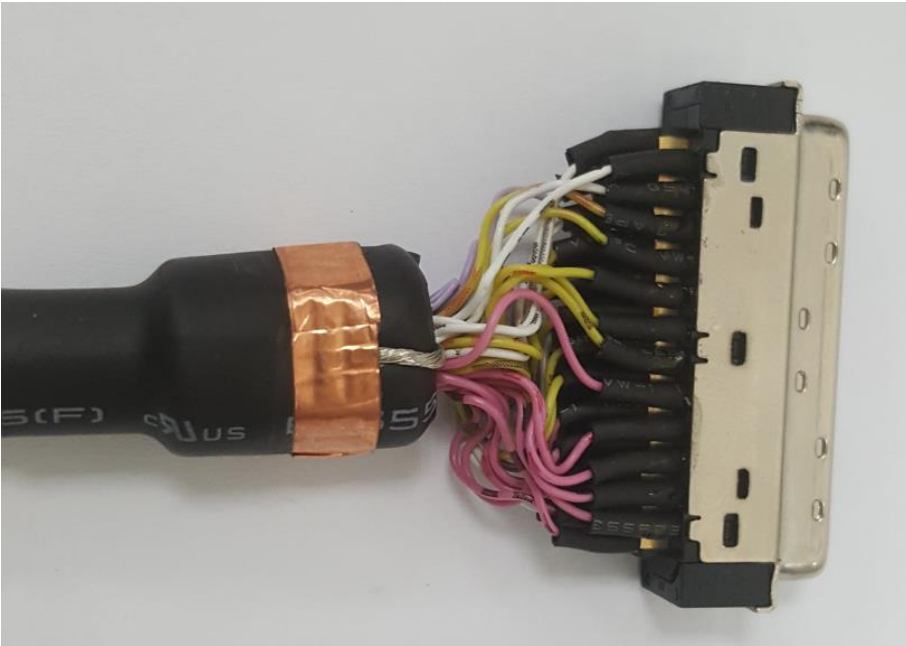

2. Screw the big metal case to fix the copper sheet, make sure the copper sheet is completely covered the extended metal sheet, and which is contact with the metal part of the connector.

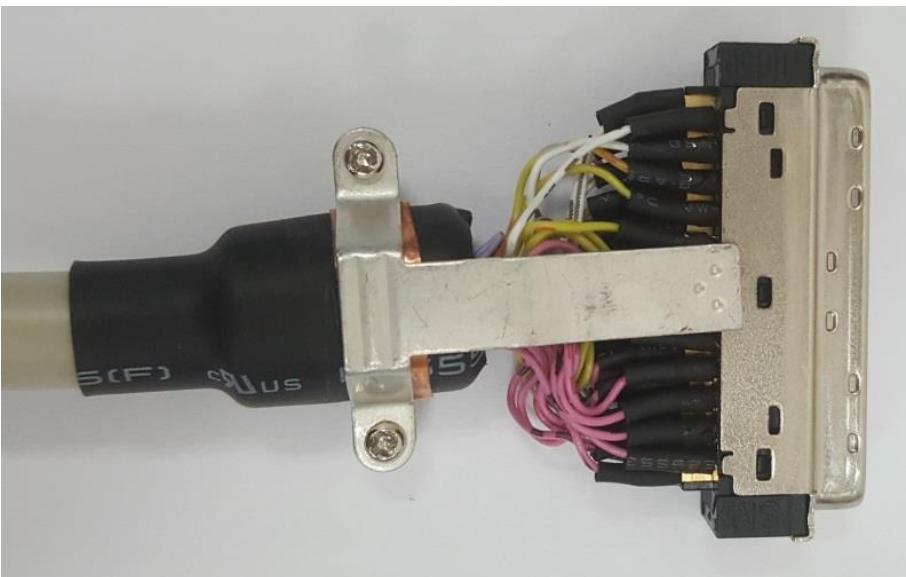

3. Put it into the connector housing as below picture shows:

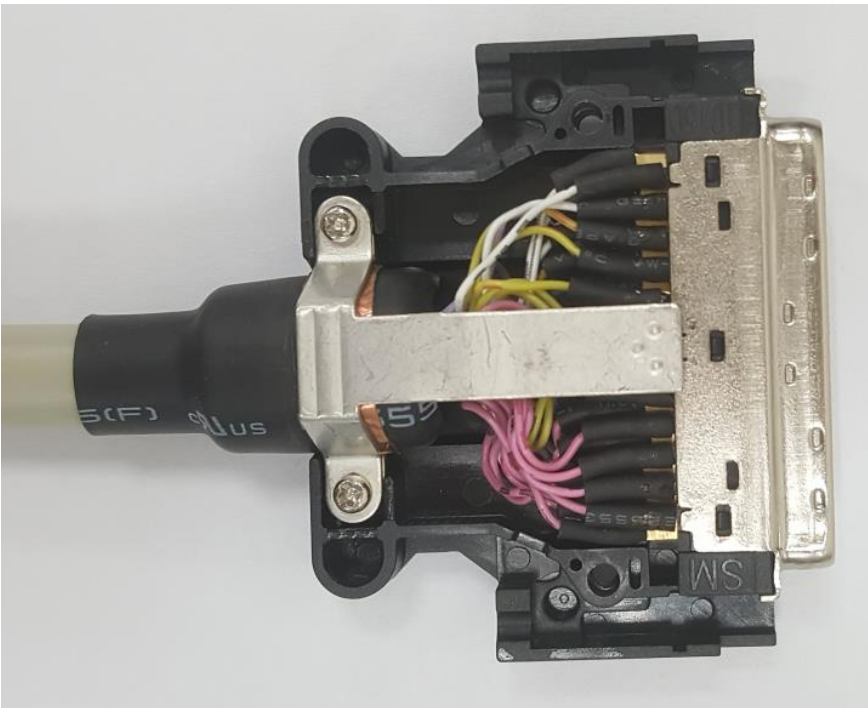

4. Fasten the housing to complete assembly:

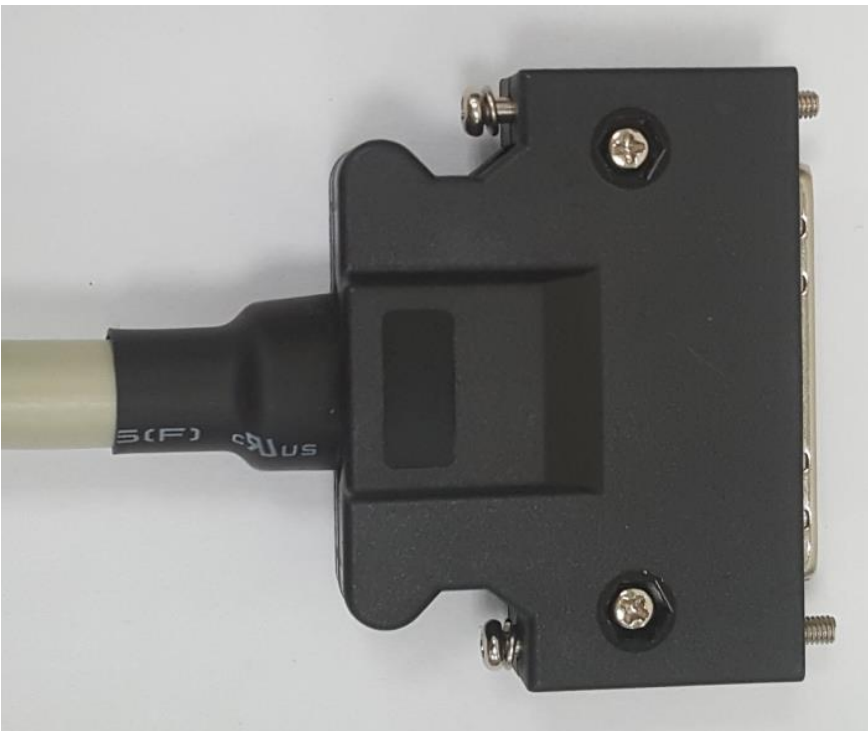

3.2.3 CN1 Terminal signal description

This section introduce the signal which mentioned in section 3.2.2.

1. CN1 terminal signal

The detailed description of each signal of total 50Pin of CN1 is as follows:

The symbols of the control modes in the following table are as follows:

Pt : Position control mode/ position mode(terminal input)

Pr : Position control mode/position mode(internal register)

S: Speed control mode

T: Torque control mode

Signal Name	Code	Pin NO	Function	Control mode
Signal ground of OP	LG	CN1-3 CN1-4 CN1-28 CN1-29 CN1-31	It's signal ground of OP. Each pin is connected internally.	ALL
Forward/reverse rotation pulse	NG	CN1-5	Open-collector type(max input frequency is 200kpps) Signal between PP-SG is "forward command". Signal between NP-SG is "reverse command". Differential receiving type (the max input	Pt

			<p>frequency is 4Mpps)</p> <p>Signal between PG-PP is “forward command”.</p> <p>Signal between NG-NP is “reverse command”.</p> <p>The command pulse type can be changed by PA13 setting.</p>	
open-collector power input	OPC	CN1-7	When the pulse train is input in the open collector type, this pin provides DC24V.	ALL
Digital I/O signal ground	SG	CN1-24 CN1-25 CN1-50	It's common pin for input signals such as SON and EMG, etc. Each PIN is internally connected and separated from LG.	ALL

Signal Name	Code	Pin NO	Function	Control mode
Encoder A-phase pulse differential output(line driver)	LA	CN1-33	Output the differential pulses of PA14 setting value in one revolution. A $\pi/2$ delay between phase A and phase B.(when the servo motor runs in CCW direction)	ALL
	LAR	CN1-34		
Encoder B-phase pulse differential output(line driver)	LB	CN1-35	The phase sequence of rotation and difference between phase A and phase B could be defined by the PA39 setting value.	ALL
	LBR	CN1-36		
Encoder Z-phase pulse differential output(line driver)	LZ	CN1-37	Output the OP signal in differential line driver type.	ALL
	LZR	CN1-38		
Encoder Z phase pulse output (open-collector)	OP	CN1-39	Output the ZERO signal of encoder. Each revolution of servo motor generate 1 pulse.	ALL
Digital input power	COM+	CN1-47 CN1-49	Input DC24V for input interface. Connect to the the positive pole of DC24V external power supply or to the VDD terminal, but you can only choose one of the two, not both ones.	ALL
Common pin of digital output	DOCOM	CN1-40	Use as common pin of output signal, it can be applied in Sink Type and Source Type. In sink type, DOCOM is connected to SG or the “-” of external 24V power. In source type, DOCOM is connected to VDD or “+” of external 24V power. Refer to section 3.3.4 for wiring detail.	ALL
Internal +24V power output	VDD (24V)	CN1-48	Output a +24V \pm 10% power source between VDD-SG, and connect to COM+ when it used as a digital interface power supply.	ALL

The signals of DI and DO are explained in detail below:

Digital Input Wiring

The users can define the DI function by editing user parameters, see the following table for details:

Signal name	code	Function	Control mode
Servo ON	SON	<p>If SON is ON, the basic circuit is on and servo is ready to run(servo ON status).</p> <p>If SON is OFF, the basic circuit is off and the servo motor is in free run status(servo OFF status).</p>	ALL
Reset	RES	<p>If the RES is ON for over 50ms, reset is valid, but may not able to clear an abnormal alarm status (refer to section 11. 1). The circuit is still on when set PD20 to XXX1.</p>	ALL
Proportion control	PC	<p>The speed controller will switch from proportion integral control to proportion control when PC is ON. When servo motor is static, 1 external pulse will generate torque and adjust position shift. Once the positioning is done(stopped), it will lock the machine shaft and turn on the proportional control signal (PC) at the same time to suppress the unnecessary torque.</p> <p>When the servo stops running for long time, you need to turn on both the proportion control signal and the torque control signal(TL) at the same time to control it below the rated torque.</p>	Pt, Pr, S

Signal name	code	Function	Control mode																																																																							
Internal torque limit selection	TL1	Internal torque limit control 2 is valid when TI1 is ON. PC25 > PA05 => PA05 PC25 < PA05 => PC25	ALL																																																																							
Speed option 1	SP1	<p>To select the speed command in speed control mode, and make it usable by setting internal parameter when using SP3.</p> <table border="1"> <thead> <tr> <th rowspan="2">Parameter setting</th> <th colspan="3">Input signals</th> <th rowspan="2">Speed command</th> </tr> <tr> <th>SP3</th> <th>SP2</th> <th>SP1</th> </tr> </thead> <tbody> <tr> <td rowspan="4">When speed option (SP3) is not used. (initial status)</td> <td></td> <td>0</td> <td>0</td> <td>NA(ZERO speed)</td> </tr> <tr> <td></td> <td>0</td> <td>1</td> <td>Inner speed command 1</td> </tr> <tr> <td></td> <td>1</td> <td>0</td> <td>Inner speed command 2</td> </tr> <tr> <td></td> <td>1</td> <td>1</td> <td>Inner speed command 3</td> </tr> <tr> <td rowspan="7">When speed option (SP3) is used.</td> <td>0</td> <td>0</td> <td>0</td> <td>NA(ZERO speed)</td> </tr> <tr> <td>0</td> <td>0</td> <td>1</td> <td>Inner speed command 1</td> </tr> <tr> <td>0</td> <td>1</td> <td>0</td> <td>Inner speed command 2</td> </tr> <tr> <td>0</td> <td>1</td> <td>1</td> <td>Inner speed command 3</td> </tr> <tr> <td>1</td> <td>0</td> <td>0</td> <td>Inner speed command 4</td> </tr> <tr> <td>1</td> <td>0</td> <td>1</td> <td>Inner speed command 5</td> </tr> <tr> <td>1</td> <td>1</td> <td>0</td> <td>Inner speed command 6</td> </tr> <tr> <td>1</td> <td>1</td> <td>1</td> <td>Inner speed command 7</td> </tr> </tbody> </table> <p>To select the speed limit in torque control mode.</p> <table border="1"> <thead> <tr> <th rowspan="2">Parameter setting</th> <th colspan="3">Input signals</th> <th rowspan="2">Speed limit</th> </tr> <tr> <th>SP3</th> <th>SP2</th> <th>SP1</th> </tr> </thead> <tbody> <tr> <td></td> <td></td> <td></td> <td></td> <td></td> </tr> </tbody> </table>	Parameter setting	Input signals			Speed command	SP3	SP2	SP1	When speed option (SP3) is not used. (initial status)		0	0	NA(ZERO speed)		0	1	Inner speed command 1		1	0	Inner speed command 2		1	1	Inner speed command 3	When speed option (SP3) is used.	0	0	0	NA(ZERO speed)	0	0	1	Inner speed command 1	0	1	0	Inner speed command 2	0	1	1	Inner speed command 3	1	0	0	Inner speed command 4	1	0	1	Inner speed command 5	1	1	0	Inner speed command 6	1	1	1	Inner speed command 7	Parameter setting	Input signals			Speed limit	SP3	SP2	SP1						S, T
Parameter setting	Input signals			Speed command																																																																						
	SP3		SP2		SP1																																																																					
When speed option (SP3) is not used. (initial status)			0	0	NA(ZERO speed)																																																																					
			0	1	Inner speed command 1																																																																					
			1	0	Inner speed command 2																																																																					
			1	1	Inner speed command 3																																																																					
When speed option (SP3) is used.	0		0	0	NA(ZERO speed)																																																																					
	0		0	1	Inner speed command 1																																																																					
	0		1	0	Inner speed command 2																																																																					
	0	1	1	Inner speed command 3																																																																						
	1	0	0	Inner speed command 4																																																																						
	1	0	1	Inner speed command 5																																																																						
	1	1	0	Inner speed command 6																																																																						
1	1	1	Inner speed command 7																																																																							
Parameter setting	Input signals			Speed limit																																																																						
	SP3	SP2	SP1																																																																							
Speed option 2	SP2																																																																									
Speed option 3	SP3																																																																									

		<table border="1"> <tr> <td rowspan="4">When speed option (SP3) is not used. (initial status)</td> <td></td> <td>0</td> <td>0</td> <td>NA(ZERO speed)</td> </tr> <tr> <td></td> <td>0</td> <td>1</td> <td>Inner speed command 1</td> </tr> <tr> <td></td> <td>1</td> <td>0</td> <td>Inner speed command 2</td> </tr> <tr> <td></td> <td>1</td> <td>1</td> <td>Inner speed command 3</td> </tr> <tr> <td rowspan="7">When speed option (SP3) is used.</td> <td>0</td> <td>0</td> <td>0</td> <td>NA(ZERO speed)</td> </tr> <tr> <td>0</td> <td>0</td> <td>1</td> <td>Inner speed command 1</td> </tr> <tr> <td>0</td> <td>1</td> <td>0</td> <td>Inner speed command 2</td> </tr> <tr> <td>0</td> <td>1</td> <td>1</td> <td>Inner speed command 3</td> </tr> <tr> <td>1</td> <td>0</td> <td>0</td> <td>Inner speed command 4</td> </tr> <tr> <td>1</td> <td>0</td> <td>1</td> <td>Inner speed command 5</td> </tr> <tr> <td>1</td> <td>1</td> <td>0</td> <td>Inner speed command 6</td> </tr> <tr> <td>1</td> <td>1</td> <td>1</td> <td>Inner speed command 7</td> </tr> </table>	When speed option (SP3) is not used. (initial status)		0	0	NA(ZERO speed)		0	1	Inner speed command 1		1	0	Inner speed command 2		1	1	Inner speed command 3	When speed option (SP3) is used.	0	0	0	NA(ZERO speed)	0	0	1	Inner speed command 1	0	1	0	Inner speed command 2	0	1	1	Inner speed command 3	1	0	0	Inner speed command 4	1	0	1	Inner speed command 5	1	1	0	Inner speed command 6	1	1	1	Inner speed command 7		
When speed option (SP3) is not used. (initial status)		0		0	NA(ZERO speed)																																																	
		0		1	Inner speed command 1																																																	
		1		0	Inner speed command 2																																																	
		1	1	Inner speed command 3																																																		
When speed option (SP3) is used.	0	0	0	NA(ZERO speed)																																																		
	0	0	1	Inner speed command 1																																																		
	0	1	0	Inner speed command 2																																																		
	0	1	1	Inner speed command 3																																																		
	1	0	0	Inner speed command 4																																																		
	1	0	1	Inner speed command 5																																																		
	1	1	0	Inner speed command 6																																																		
1	1	1	Inner speed command 7																																																			
Forward rotation activated	ST1	<p>When start the servo motor , it runs in the following directions:</p> <table border="1"> <thead> <tr> <th colspan="2">Input signals</th> <th rowspan="2">Servo motor starting direction</th> </tr> <tr> <th>ST2</th> <th>ST1</th> </tr> </thead> <tbody> <tr> <td>0</td> <td>0</td> <td>Stop(servo locked)</td> </tr> <tr> <td>0</td> <td>1</td> <td>CCW</td> </tr> <tr> <td>1</td> <td>0</td> <td>CW</td> </tr> <tr> <td>1</td> <td>1</td> <td>Stop(servo locked)</td> </tr> </tbody> </table> <p>If both ST1 and ST2 are ON or OFF during operation, the servo will be decelerated to stop base on PC18 and the motor will be locked.</p>			Input signals		Servo motor starting direction	ST2	ST1	0	0	Stop(servo locked)	0	1	CCW	1	0	CW	1	1	Stop(servo locked)																																	
Input signals		Servo motor starting direction																																																				
ST2	ST1																																																					
0	0	Stop(servo locked)																																																				
0	1	CCW																																																				
1	0	CW																																																				
1	1	Stop(servo locked)																																																				
Reverse rotation activated	ST2					S																																																

Forward rotation option	RS1	<p>To select the torque direction of the servo motor. The direction is as follows:</p> <table border="1" style="margin-left: auto; margin-right: auto;"> <thead> <tr> <th colspan="2">Input signals</th> <th rowspan="2">the torque direction</th> </tr> <tr> <th>RS2</th> <th>RS1</th> </tr> </thead> <tbody> <tr> <td>0</td> <td>0</td> <td>no torque generated</td> </tr> <tr> <td>0</td> <td>1</td> <td>Forward rotation torque, reverse rotation regeneration.</td> </tr> <tr> <td>1</td> <td>0</td> <td>Reverse rotation torque, forward rotation regeneration.</td> </tr> <tr> <td>1</td> <td>1</td> <td>no torque generated</td> </tr> </tbody> </table>	Input signals		the torque direction	RS2	RS1	0	0	no torque generated	0	1	Forward rotation torque, reverse rotation regeneration.	1	0	Reverse rotation torque, forward rotation regeneration.	1	1	no torque generated	T
	Input signals		the torque direction																	
RS2	RS1																			
0	0		no torque generated																	
0	1		Forward rotation torque, reverse rotation regeneration.																	
1	0		Reverse rotation torque, forward rotation regeneration.																	
1	1	no torque generated																		
Reverse rotation option	RS2																			
Homing	ORGP	<p>This activated signal assign current position to the origin in Pr mode.</p> <p>Turn the SHOM ON to activate homing.</p>	Pr																	
Return to origin	SHOM	<p>In the internal position register mode, when searching the origin, the function of searching the origin is activated after SHOM is connected.</p>	Pr																	
Electronic gear option 1	CM1	<p>When CM1 and CM2 are used, the combination of CM1 and CM2 can be used for selecting the E-gears, and the parameter can set the numerator with 4 kinds of electronic gear ratios.</p> <p>CM1 and CM2 cannot be used in the absolute position detection system.</p> <table border="1" style="margin-left: auto; margin-right: auto;"> <thead> <tr> <th colspan="2">Input signal</th> <th rowspan="2">Electronic gear numerator</th> </tr> <tr> <th>CM2</th> <th>CM1</th> </tr> </thead> <tbody> <tr> <td>0</td> <td>0</td> <td>PA06(CMX)</td> </tr> <tr> <td>0</td> <td>1</td> <td>PC32(CMX2)</td> </tr> <tr> <td>1</td> <td>0</td> <td>PC33(CMX)</td> </tr> <tr> <td>1</td> <td>1</td> <td>PC34(CMX4)</td> </tr> </tbody> </table>	Input signal		Electronic gear numerator	CM2	CM1	0	0	PA06(CMX)	0	1	PC32(CMX2)	1	0	PC33(CMX)	1	1	PC34(CMX4)	Pt
Input signal			Electronic gear numerator																	
CM2	CM1																			
0	0	PA06(CMX)																		
0	1	PC32(CMX2)																		
1	0	PC33(CMX)																		
1	1	PC34(CMX4)																		
Electronic gear option 2	CM2																			

Clear	CR	Turn CR on to clear the position control counter droop pulses on its leading edge. When PD18 is set to xxx1, the pulse are always cleared if CR is on.	Pt, Pr
Gain switching option	CDP	When using this signal, enable CDP and turn CDP on to change the gain values to the multiplier of related parameters.	ALL
External emergency stop	EMG	Turn EMG OFF, the motor will be in emergency stop state, servo will be off and the electromagnetic brake will be activated. Turning EMG ON will release the emergency stop status in urgent cases. When set the value of PD01 to 1XXX, this signal will be automatically on(keeps ON).	ALL
Limit of forward rotation	LSP	To use as the switch for forward rotation limit. When LSP is on, the motor can be operate forwardly.	Pt, Pr, S
Limit of reverse rotation	LSN	To use the switch for reverse rotation limit. When LSN is on, the motor can be operate reversely.	Pt
Inhibit pulse input	INHP	To inhabit pulse input. In position mode, turn INHP on to make the external pulse input command invalid.	

Signal name	Code	Function	Control mode																																								
Control switch	LOP	In position/speed control switching mode, it can be used to select the control mode.	Refer to introduction in different control mode																																								
		<table border="1"> <thead> <tr> <th>LOP</th> <th>Control mode</th> </tr> </thead> <tbody> <tr> <td>0</td> <td>Position</td> </tr> <tr> <td>1</td> <td>Speed</td> </tr> </tbody> </table>		LOP	Control mode	0	Position	1	Speed																																		
		LOP		Control mode																																							
0	Position																																										
1	Speed																																										
In speed/torque control switch mode, it can be used to select the control mode.																																											
		<table border="1"> <thead> <tr> <th>LOP</th> <th>control mode</th> </tr> </thead> <tbody> <tr> <td>0</td> <td>speed</td> </tr> <tr> <td>1</td> <td>torque</td> </tr> </tbody> </table>	LOP	control mode	0	speed	1	torque																																			
LOP	control mode																																										
0	speed																																										
1	torque																																										
		In torque/position control switch mode, it can be used to select the control mode.																																									
		<table border="1"> <thead> <tr> <th>LOP</th> <th>control mode</th> </tr> </thead> <tbody> <tr> <td>0</td> <td>torque</td> </tr> <tr> <td>1</td> <td>position</td> </tr> </tbody> </table>	LOP	control mode	0	torque	1	position																																			
LOP	control mode																																										
0	torque																																										
1	position																																										
Position command option 1	POS1	<table border="1"> <thead> <tr> <th>Position command</th> <th>POS6</th> <th>POS5</th> <th>POS4</th> <th>POS3</th> <th>POS2</th> <th>POS1</th> <th>CTRG</th> </tr> </thead> <tbody> <tr> <td>P0</td> <td>0</td> <td>0</td> <td>0</td> <td>0</td> <td>0</td> <td>0</td> <td>↑</td> </tr> <tr> <td>P1</td> <td>0</td> <td>0</td> <td>0</td> <td>0</td> <td>0</td> <td>1</td> <td>↑</td> </tr> <tr> <td>~</td> <td></td> <td></td> <td></td> <td></td> <td></td> <td></td> <td></td> </tr> <tr> <td>P50</td> <td>1</td> <td>1</td> <td>0</td> <td>0</td> <td>1</td> <td>0</td> <td>↑</td> </tr> </tbody> </table>	Position command	POS6	POS5	POS4	POS3	POS2	POS1	CTRG	P0	0	0	0	0	0	0	↑	P1	0	0	0	0	0	1	↑	~								P50	1	1	0	0	1	0	↑	Pr
Position command	POS6	POS5	POS4	POS3	POS2	POS1	CTRG																																				
P0	0	0	0	0	0	0	↑																																				
P1	0	0	0	0	0	1	↑																																				
~																																											
P50	1	1	0	0	1	0	↑																																				
Position command option 2	POS2																																										
Position command option 3	POS3																																										
Position command option 4	POS4																																										

Position command option 5	POS5									
		P51	1	1	0	0	1	1	↑	
Position command option 6	POS6	~								
		P63	1	1	1	1	1	1	↑	
Position command trigger	CTR G	In position mode with internal commands(Pr mode), when CTRG is ON, it choose a position command by the ON/OFF status according to combination of POS1~POS6.								Pr
Event trigger Pr command 1	EV1	<p>The event trigger PR command 1-4: The status change of EV1~EV4 is used as a trigger event This can be set by PF83 or PF84. Applicable case: sensor, trigger preset procedure.</p>								Pr
Event trigger Pr command 2	EV2									
Event trigger Pr command 3	EV3									
Event trigger Pr command 4	EV4									
Delta ABS transfer mode	ABSE	<p>When ABSE is on, servo will enter ABS mode and enables ABSQ, ABSR, ABSD, ABSC. When ABSE is on, the functions of DI4,DO2,DO3 can not be defined by the parameters. The DI4 function is ASDQ, the DO2 function is ABSR, the DO3 function is ABSD. In addition, ABSC can be defined via the DI parameter setting.</p>								ALL
Mitsubishi ABS transfer mode	ABSM	<p>When ABSM is on, servo will enter ABS mode and enables ABSR, ABST, ABSB0, ABSB1,ABSC. When ABSE is on, the functions of DI4,DO2,DO3,DO4 can not be defined by the parameters. The DI4 function is ABSR, the DO2 function is ABST, the DO3 function is</p>								ALL

		ABSB0, the DO4 function is ABSB1. In addition, ABSC can be defined via the DI parameter setting.																										
Delta/Mitsubishi original position setting	ABSC	When ABSC is on, the number of revolution stored in absolute encoder are cleared. But this digital input is only valid when ABSE or ABSM is on.	ALL																									
Motor stopped signal in Pr mode	STOP	The motor stops running, when the stop signal is activated in Pr mode.	Pr																									
Torque command option 1	TC1	<table border="1"> <thead> <tr> <th rowspan="2">Torque command code</th> <th colspan="2">Input signal</th> <th rowspan="2">Command source</th> <th rowspan="2">Description</th> </tr> <tr> <th>TC2</th> <th>TC1</th> </tr> </thead> <tbody> <tr> <td>T1</td> <td>0</td> <td>0</td> <td>N/A(no command)</td> <td>For factory test only</td> </tr> <tr> <td>T2</td> <td>0</td> <td>1</td> <td rowspan="3">Internal register parameter</td> <td>PC73 value</td> </tr> <tr> <td>T3</td> <td>1</td> <td>0</td> <td>PC74 value</td> </tr> <tr> <td>T4</td> <td>1</td> <td>1</td> <td>PC75 value</td> </tr> </tbody> </table>	Torque command code	Input signal		Command source	Description	TC2	TC1	T1	0	0	N/A(no command)	For factory test only	T2	0	1	Internal register parameter	PC73 value	T3	1	0	PC74 value	T4	1	1	PC75 value	T
Torque command code	Input signal			Command source	Description																							
	TC2		TC1																									
T1	0		0	N/A(no command)	For factory test only																							
T2	0		1	Internal register parameter	PC73 value																							
T3	1	0	PC74 value																									
T4	1	1	PC75 value																									
Torque command option 2	TC2																											
Pt-Pr switching mode	Pt-Pr	Switch mutually between Pt and Pr. Pt-Pr OFF: Pt mode Pt-Pr ON: Pr mode	Pt, Pr																									



NOTE

1. ST1/RS2 and ST2/RS1 automatically switch signals internally when setting PA01 in speed mode (ST1) or torque mode (RS2).
2. When the user need to define the terminal function by himself, set PA01=0□□□ to activate. If PA01 is set to 1□□□, the recommended setting value of the DI/DO digital input function will be its setting value.
3. For detailed DI setting of absolute servo system, please refer to CH14.

Digital Output DO

The user can define the DO function by setting related parameters. Please refer to details in the following table:

Signal name	Code	Function	Control mode
Ready	RD	When servo is ready to operate, RD will turn ON.	ALL
Alarm	ALM	When power is off or protection circuit cuts off the main circuit, ALM signal will turn OFF. When there is no alarm occurs, ALM will be ON 1 second after the power turning on.	ALL
In-position ready	INP	INP turns on when the number of error pulses is in the preset range. The range could be changed by parameter setting. When the in-position range is increased, INP may be kept conductive during low-speed rotation.	Pr, Pt
Speed attained	SA	When servo motor speed is close to the setting value, the SA will turn ON. The SA will keep ON when setting speed is below 50 rpm.	S
Homing complete	HOME	After homing is completed, the HOME signal turns ON.	Pr
Torque limiting control	TLC	TLC is on as motor generated torque reaches the setting of inner torque limit 1 (PA05). TLC is off when SON signal turns off.	Pr, Pt, S
Speed limiting control	VLC	In torque control mode, VLC is on when motor reaches speed limit by internal speed command 1-7. VLC is off when SON signal turns off.	T
Electromagnetic brake interlock	MBR	When using electromagnetic brake motor, please set PA01 to $\square 1 \square \square$. MBR is off if servo turns off or alarm occurs. MBR is on if servo turns on.	ALL

Warning	WNG	WNG is on when Warning occurs. WNG signal is turning off when no warning occurs.	ALL
Zero speed detection	ZSP	ZSP will be ON when servo motor speed runs to below 50 rpm. the zero speed range can be adjusted by parameter.	ALL
Internal position command completion output	CMD OK	CMDOK is on when internal positioning command is completed or stopped.	Pr
overload level reached	OLW	The OLW signal is ON when reaching the overload level setting.	ALL
Internal position reached	MC_OK	When the digital output of CMD_OK and INP are ON, the MC_OK signal will turn on. Otherwise, it will turn off.	Pr
Position command overflow	OVF	The OVF signal is ON when the position command overflows.	Pr
Software positive limit reached	SWPL	When the position command exceeds the software positive limit(PF86)setting value, SWPL will be ON. Otherwise, SWPL will be OFF.	Pr
Software negative limit reached	SWNL	When the position command is less than the software negative limit(PF87)setting value, SWNL will be ON. Otherwise, SWNL will be OFF.	Pr
Delta absolute system warning output	ABSW	The related alarms of Delta's absolute system is indicated by this DO output.	ALL
Mitsubishi absolute position lost	ABSV	ABSV is ON when Mitsubishi absolute position value is lost.	ALL

Mode switching status	LOPM	<p>In control switching mode, the current control mode (related to LOP) is displayed as follows:</p> <p>1. when PA01=<u>XXX1</u>, LOPM represents the current control mode as follows:</p> <p>LOPM OFF: position mode</p> <p>LOPMON: speed mode</p> <p>2. When PA01=<u>XXX3</u>, LOPM represents the current control mode as follows:</p> <p>LOPM OFF: speed mode</p> <p>LOPM ON: torque mode</p> <p>3. When PA01=<u>XXX5</u>, LOPM represents the current control mode as follows:</p> <p>LOPM OFF: torque mode</p> <p>LOPM ON: position mode</p>	ALL
Software digital output	S_DO0 ~ S_DOF	To output bit0~bit15 of PD33.	ALL



NOTE

1. INP and SA automatically switch signals internally when setting PA01 in speed mode or position mode.
2. TLC and VLC automatically switch signals internally when setting PA01 in speed mode or position mode.

Shihlin servo has 9 digital input (PD02~ PD09 and PD21) and 5 digital output. In different control modes, its function is also different, you can refer to below table for details.

Recommended setting value for DI digital input function

DI code	Signal	Function	Pt	Pr	S	T	Pt-S	Pt-T	Pr-S	Pr-T	S-T
0x01	SON	Servo ON	DI1	DI1	DI1	DI1	DI1	DI1	DI1	DI1	DI1
0x02	RES	Reset	DI5	DI5	DI5	DI5	DI5	DI5	DI5	DI5	DI5
0x03	PC	Proportion control	DI3								
0x04		None									
0x05	TL1	Inner torque limit option	DI4								
0x06	SP1	Speed option 1			DI6	DI6	DI2	DI2		DI5	DI6
0x07	SP2	Speed option 2			DI2	DI2					DI2
0x08	SP3	Speed option 3									
0x09	ST1	Forward rotation start			DI3		DI3		DI3		
0x0A	ST2	Reverse rotation start			DI4		DI4		DI6		
0x0A	RS1	Forward rotation option				DI4		DI4		DI6	DI4
0x09	RS2	Reverse rotation option				DI3		DI3		DI3	DI3
0x0B	ORGP	Origin position									
0x0C	SHOM	Return to origin									
0x0D	CM1	Electronic gear option1	DI2								
0x0E	CM2	Electronic gear option2									
0x0F	CR	Clear	DI6	DI6			DI6	DI6			

0x10	CDP	Gain switch signal										
0x11	LOP	Control switching					DI6	DI6	DI5	DI6	DI2	
0x12	EMG	External emergency stop	DI7	DI7	DI7	DI7	DI7	DI7	DI7	DI7	DI7	DI7
0x13	POS1	Position command option 1		DI2						DI2	DI2	
0x14	POS2	Position command option 2		DI3								
0x15	POS3	position command option 3										
0x16	CTRG	Position command trigger		DI4						DI4	DI4	
0x18	LSP	Limit of forward rotation	DI9	DI9	DI9	DI9	DI9	DI9	DI9	DI9	DI9	DI9
0x19	LSN	Limit of reverse rotation	DI8	DI8	DI8	DI8	DI8	DI8	DI8	DI8	DI8	DI8
0x1A	POS4	Position command option 4										
0x1B	POS5	Position command option 5										
0x1C	POS6	Position command option 6										
0x1D	INHP	Inhabit pulse input										
0x1E	EV1	Event trigger Pr command 1										
0x1F	EV2	Event trigger Pr command 2										
0x20	EV3	Event trigger Pr command 3										
0x21	EV4	Event trigger Pr										

		command 4									
0x22	ABSE	Enable Delta absolute system									
0x22	ABSM	Enable Mitsubishi absolute system									
0x23	ABSC	Absolute system origin setting									
0x24	STOP	Pr mode stop command									
0x2D	TC1	Torque command option 1									
0x2E	TC2	Torque command option 2									
0x2F	Pt-Pr	Pt-Pr switching mode									

Recommended setting value for DO digital output function

DO code	Signal	Function	Pt	Pr	S	T	Pt-S	Pt-T	Pr-S	Pr-T	S-T
0x01	RD	Ready	DO5	DO5	DO5	DO5	DO5	DO5	DO5	DO5	DO5
0x02	ALM	Alarm	DO3	DO3	DO3	DO3	DO3	DO3	DO3	DO3	DO3
0x03	INP	In-position ready	DO1	DO1			DO1	DO1	DO1	DO1	
0x03	SA	Speed attained			DO1		DO1		DO1		DO1
0x04	HOME	Homing complete									
0x05	TLC	Torque limiting control	DO4		DO4		DO4	DO4	DO4	DO4	DO4
0x05	VLC	Speed limiting control				DO4		DO4		DO4	DO4
0x06	MBR	Electromagnetic brake interlock									
0x07	WNG	Warning				DO1					
0x08	ZSP	Zero speed detection	DO2	DO2	DO2	DO2	DO2	DO2	DO2	DO2	DO2
0x09	CMDOK	Inner position command completion output		DO4					DO4	DO4	
0x0A	OLW	Overload level reached warning									
0x0B	MC_OK	Both CMDOK and INP are reached the level									

0x0C	OVF	Position command overflow									
0x0D	SWPL	output of software positive limit reached									
0x0E	SWNL	Output of software negative limit reached									
0x0F	ABSW	Absolute system warning(Delta)									
0x10	ABSV	Absolute system lost warning (Mitsubishi)									
0x17	LOPM	Mode switching status									
0x20 ~ 0x2F	S_DO1 ~ S_SOF	Software digital output 1- software digital output 16	Applicable in all modes								

3.2.4 Interface wiring diagram

(1) Digital input in SINK type

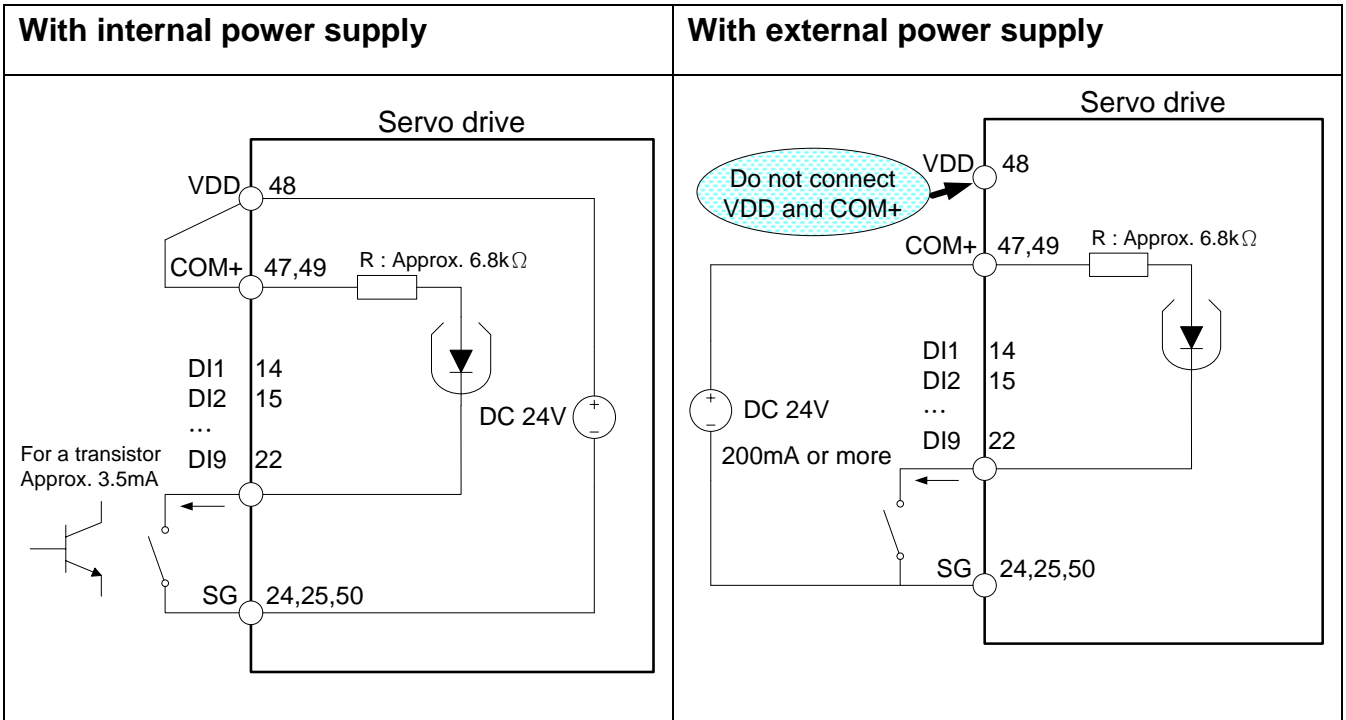

(2) Digital input in Source type

In this mode, all digital input signal are in Source type, and Source output is disabled.

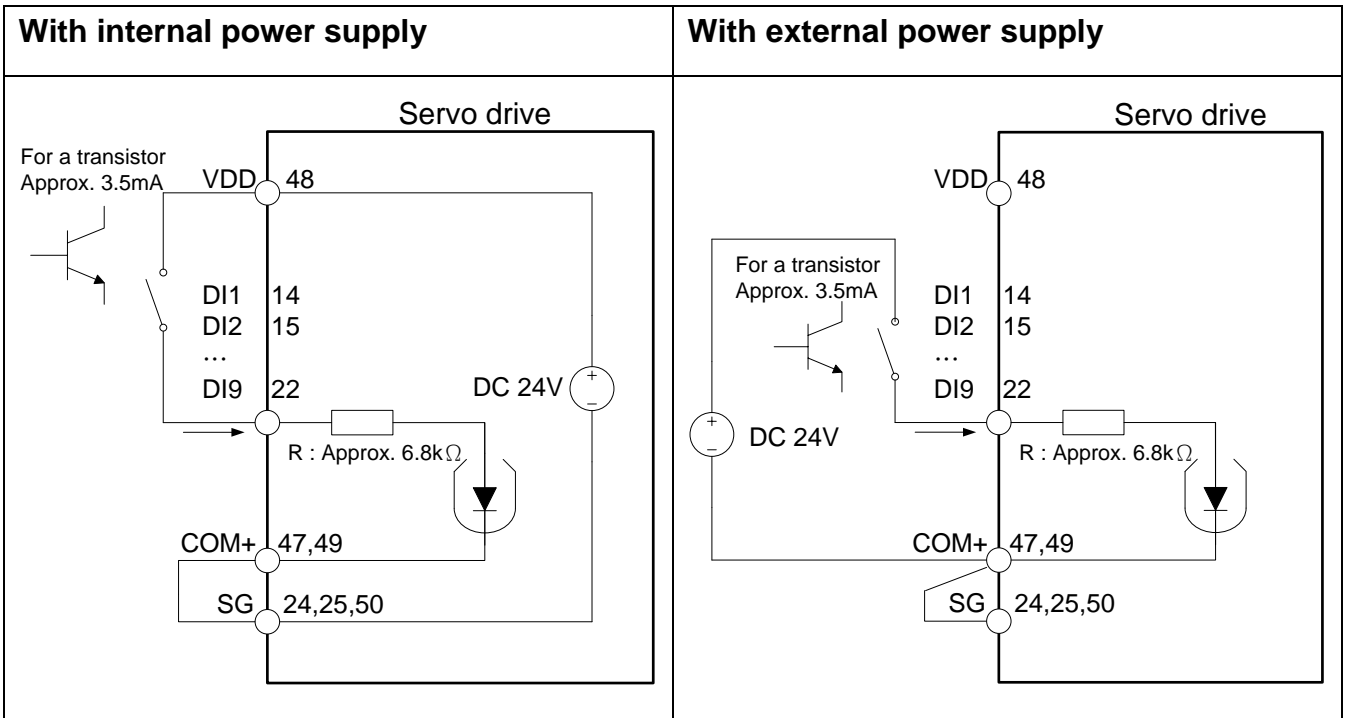

(3) Digital output

It can drive Lamp, Relay and photocoupler when a diode for relay load and a suppressing resistor for lamp load is installed. (Permissible current: below 40 mA; surge current: below 100 mA).

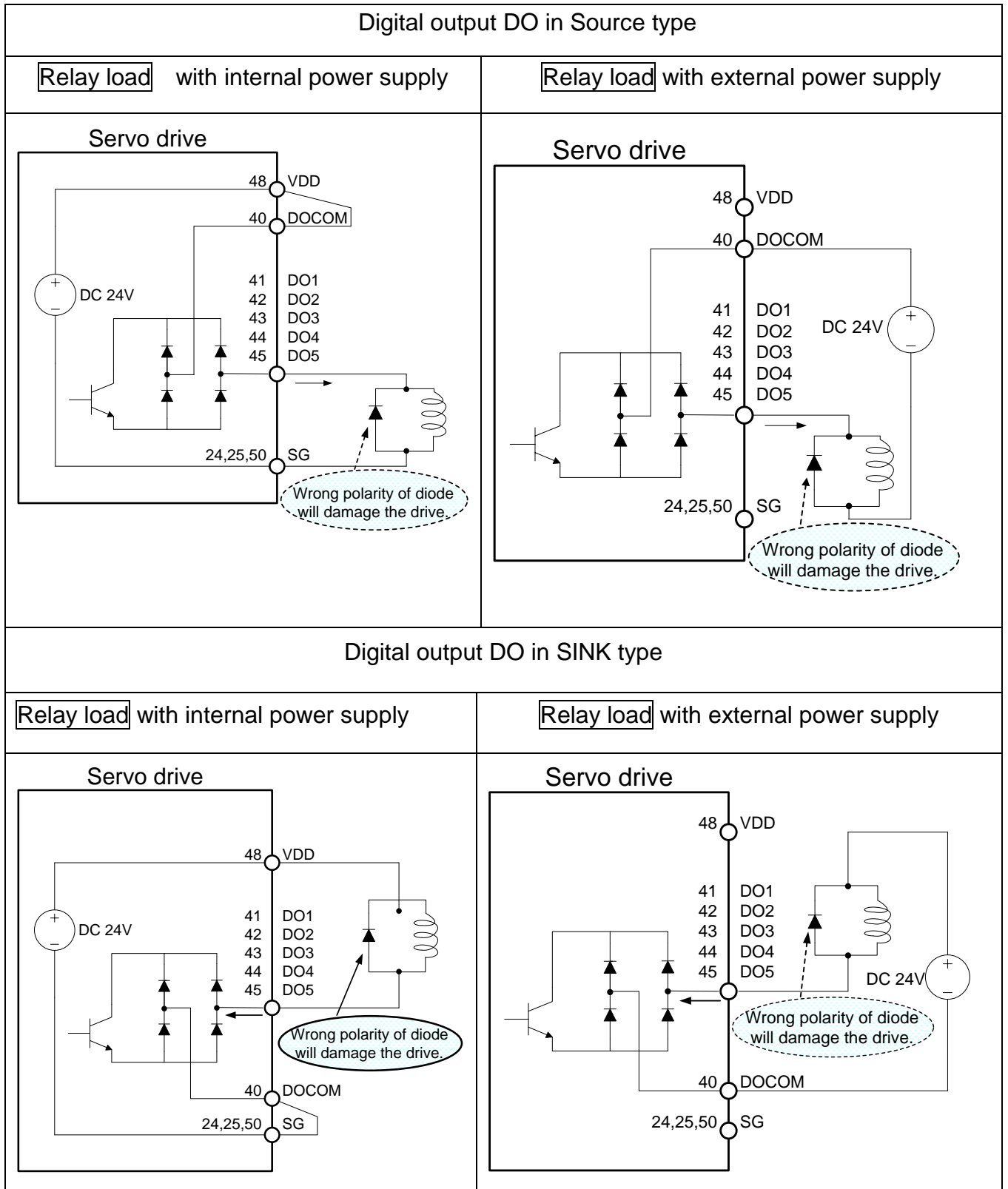

(4) Encoder position output

Encoder output contains open-collector type and differential line driver type. Open-collector type output is only available for CN1-39(OP).

The maximum input current of the open-collector encoder pulse detection circuit is 35mA.

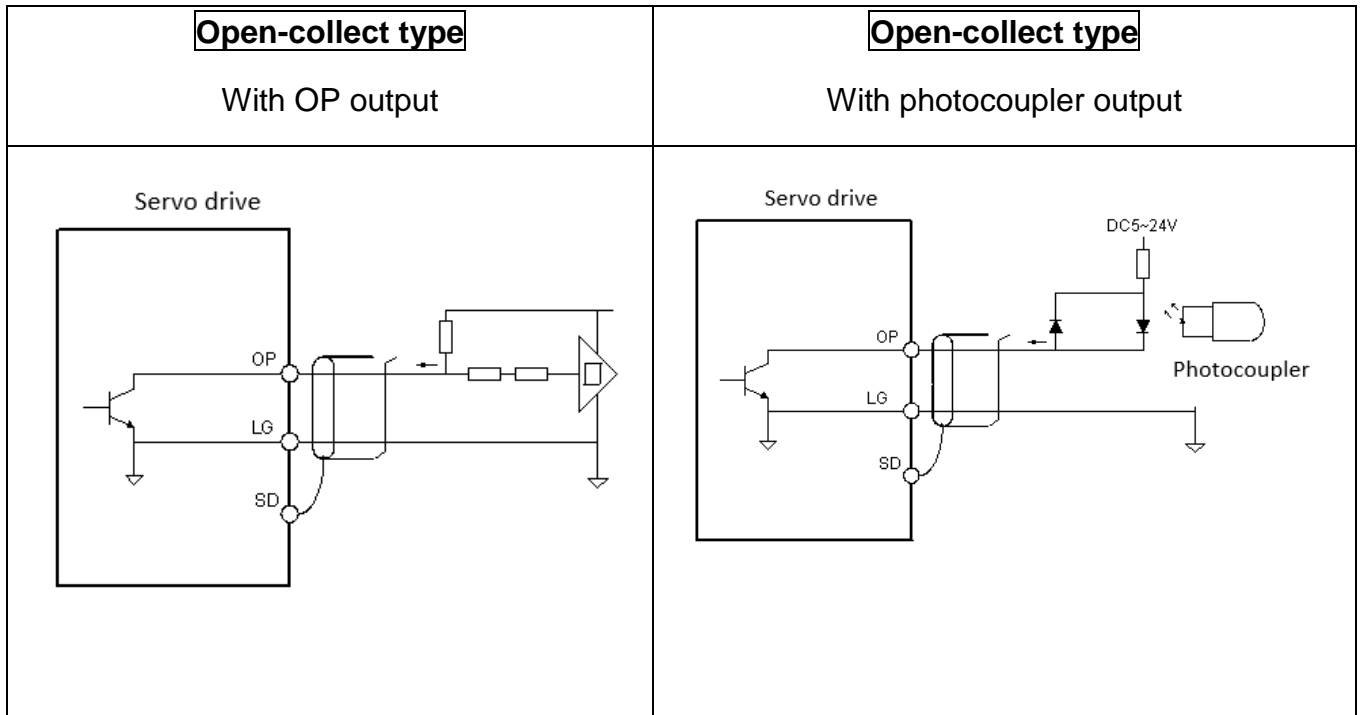

The maximum output current of the differential line drive system is 20mA.

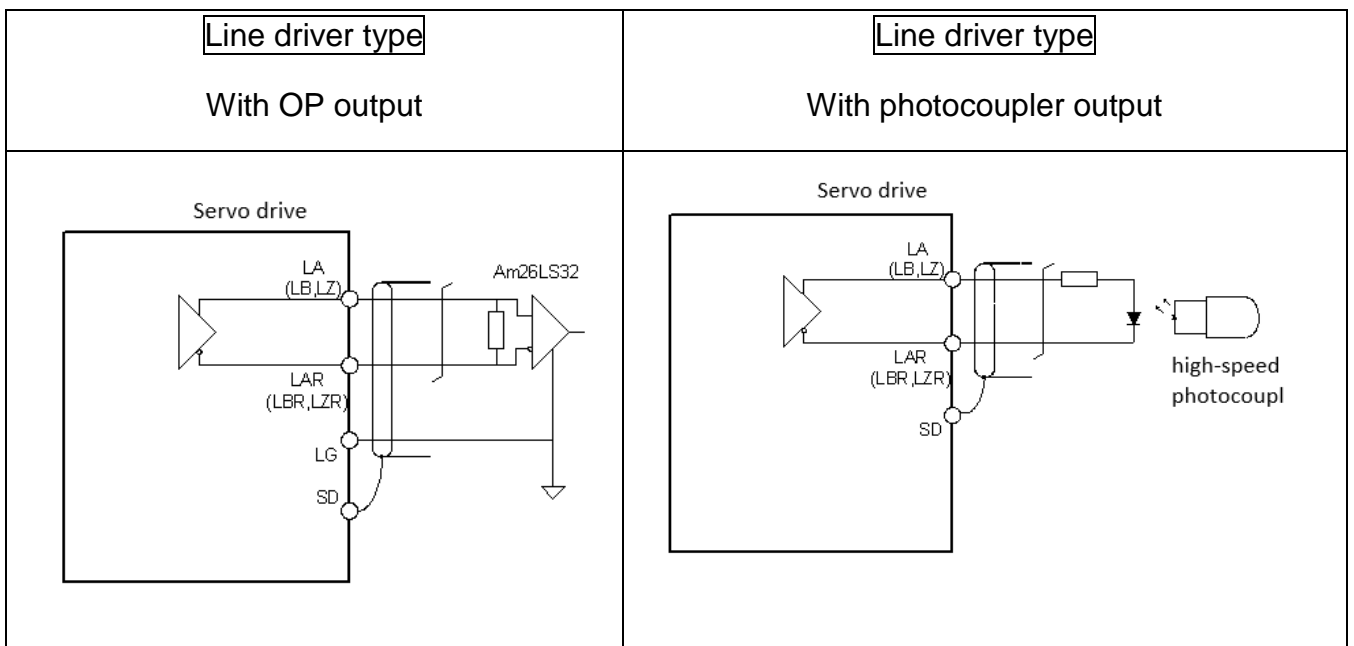

(5) Pulse command input

Pulse command can be input by open-collector type (maximum input pulse is 200kpps) and differential line driver type(maximum input pulse is 4Mpps).

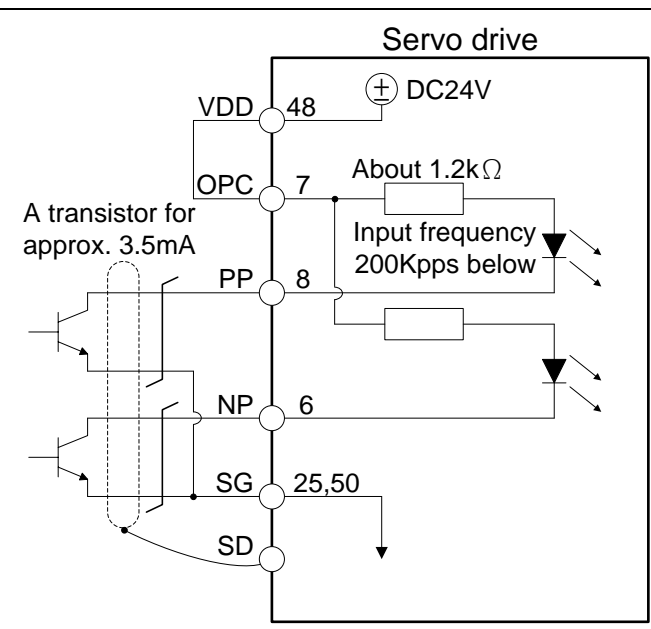
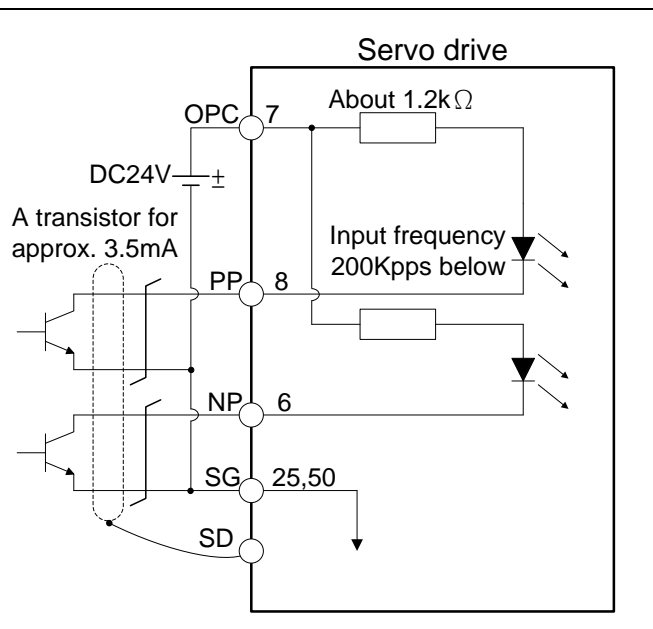
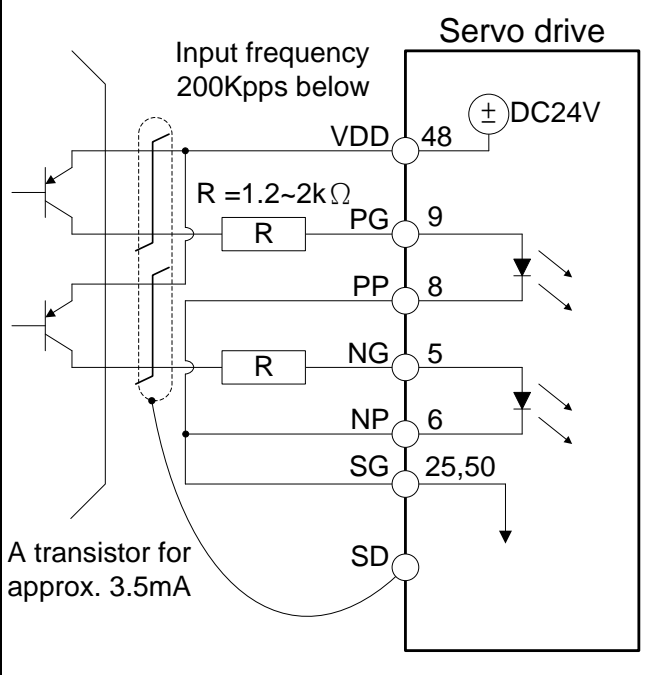
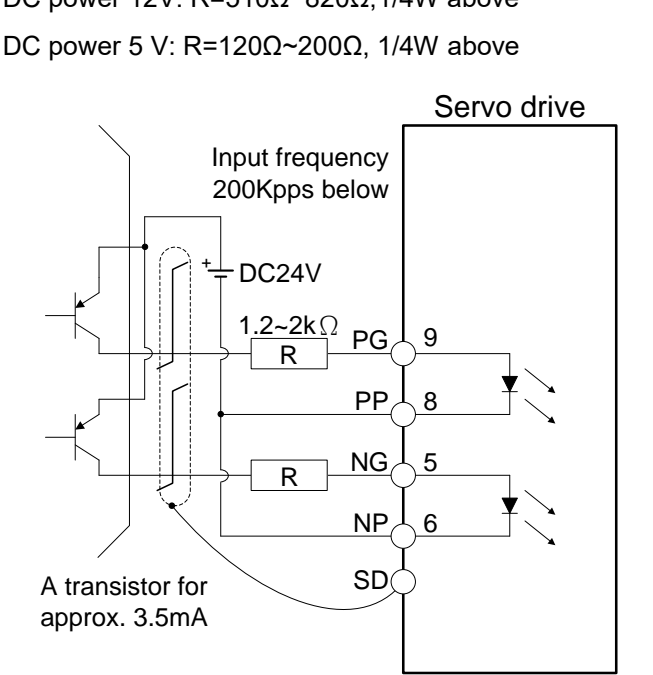
<p>Inner power supply for sink mode (NPN)</p> 	<p>External power supply for sink mode (NPN)</p> 
<p>Inner power supply for source mode (PNP)</p> <p>★Make sure to connect an external resistor with $R=1.2k\Omega\sim 2k\Omega$ & 1/4W above, to avoid burning the drive.</p> 	<p>External power supply for source mode (PNP)</p> <p>★Make sure to connect an external resistor to avoid burning the drive.</p> <p>DC power 24V: $R=1.2k\Omega\sim 2k\Omega$, 1/4W above DC power 12V: $R=510\Omega\sim 820\Omega$, 1/4W above DC power 5 V: $R=120\Omega\sim 200\Omega$, 1/4W above</p> 
<p>Differential(Line Driver)type</p>	

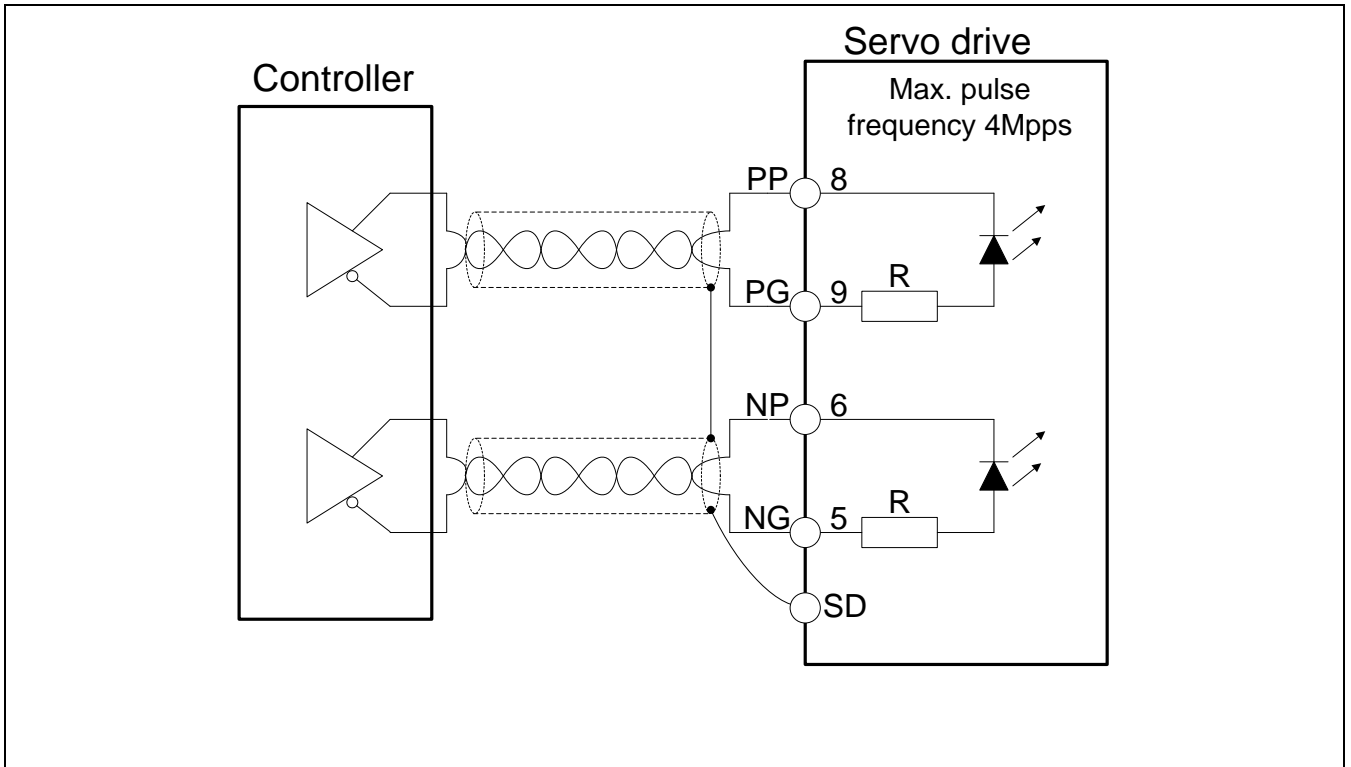

Note 1: It is recommended to use a twisted pair shielding wire for PP-PG and for NP-NG.

3.2.5 User-specified DI and DO signals

The preset DI and DO signals of Shihlin Servo are the signals of the position mode. If the preset DI/DO signals is not base on customer's requirement or customer adjusted PA01 to change control mode, you can redo the DI/DO signal setting. DI1 ~ DI12 and DO1 ~ DO5 signal are set by PD02~PD09 & PD21 and PD10~PD14 separately. You can input the DI code or DO code in the corresponding parameters to set its function. Below table will explain the DI/DO corresponding CN1 Pin and its parameters.

CN1 Pin	Signal	Parameter
CN-14	DI1	PD02
CN-15	DI2	PD03
CN-16	DI3	PD04
CN-17	DI4	PD05
CN-18	DI5	PD06
CN-19	DI6	PD07
CN-20	DI7	PD08
CN-21	DI8	PD09
CN-22	DI9	PD21

CN1 Pin	Signal	Parameter
CN-41	DO1	PD10
CN-42	DO2	PD11
CN-43	DO3	PD12
CN-44	DO4	PD13
CN-45	DO5	PD14

3.3 CN2 encoder signal wiring and description

The internal encoder connector pin assignment and terminal appearance as below:

(1)CN2 connector (Female)

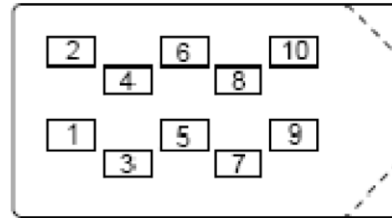

3M connector rear view

(2)CN2 connector (Male)



Connector side view

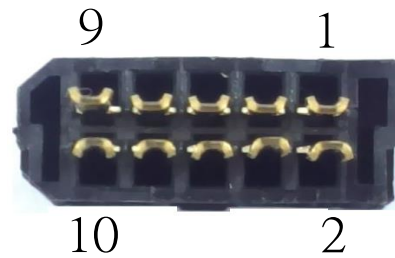

Molex connector rear view

CN2 incremental/absolute encoder signal table:

Pin	Pin marking	Signal
1, 3	Vcc(5V)	5V power supply for encoder
2	GND	5V ground
4	GNDB	3. 6V ground
5	Vcc(3. 6V)	3. 6V power battery for encoder
6	ENCP	Encoder communication(+)
7	ENCN	Encoder communication(-)
8,9,10	--	--
Casing	Shielding	Shield

3.3.1 Encoder lead wire connector specifications

Low capacity motor

The applicable Shihlin servo capacity is shown in the table below

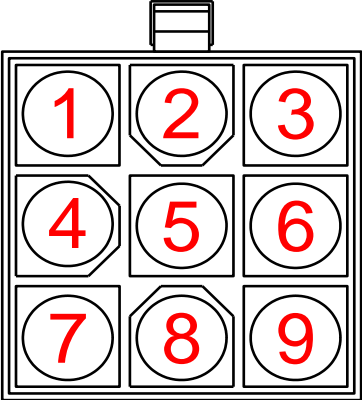
Drive capacity	Motor model name	
100W	SME – L01030○□□□	
200W	SME – L02030○□□□	
400W	SME – L04030○□□□	
750W	SME – L07530○□□□	
1kW	SME – L10030○□□□	

Pin	Pin marking	Signal
1	--	--
2	--	--
3	Vcc(3.6V)	3.6V power supply for battery
4	GNDB	3.6V ground
5	ENCN	encoder communication(-)
6	ENCP	encoder communication(+)
7	Vcc(5V)	5V power supply for encoder
8	GND	5V ground
9	Shielding	Shield

- ★ Note: the above wiring connects to the motor itself.
- ★ Refer to P2 for □□□ meaning.

3.4 CN3/CN3L communication port wiring and description

Shihlin servo CN3/CN3L are interface for RS-485 communication. The user can perform parameter setting, status monitoring, test operation and other actions by connecting the driver to a computer which is installed with Shihlin servo communication software. The CN3/CN3L allows RS485 communication between servo and the computer. The RS485 provides a longer distance communication and simultaneous connection of multiple drives.

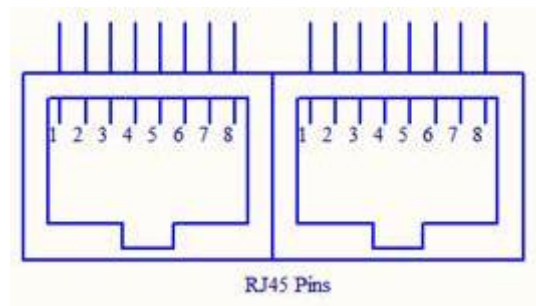

CN3/CN3L		Function
Pin NO	Pin marking	
1~3		NC
4	RS-485-B	Trans/receive data with the differential terminal B.
5	RS-485-A	Trans/receive data with the differential terminal A.
6-8		NC



NOTE

1. For RS-485 communication details, please refer to section 9.1

3.5 CN4 USB communication port

Shihlin servo drive provides USB communication slot(CN4) which is convenient to plug in and operate. Same as RS-485, when CN4 is connected to PC with universal mini-USB, you can use a PC with Shihlin communication software to perform parameter setting, status monitoring and test operation, etc.

Mini-USB is quite common in the market and very easy to buy, which greatly increases the convenience of users.

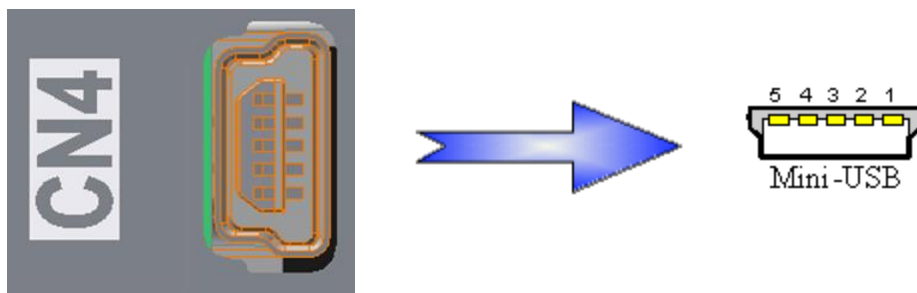

The following table shows Mini-USB standard pin assignment:

Pin NO	Pin function
1	+5V
2	D-
3	D+
4	NC
5	GND

3.6 CN5 absolute encode battery connector.

When using an absolute servo motor, an external absolute encoder battery box is required. CN5 is a battery connector. After the battery is connected, the parameter setting can be performed.

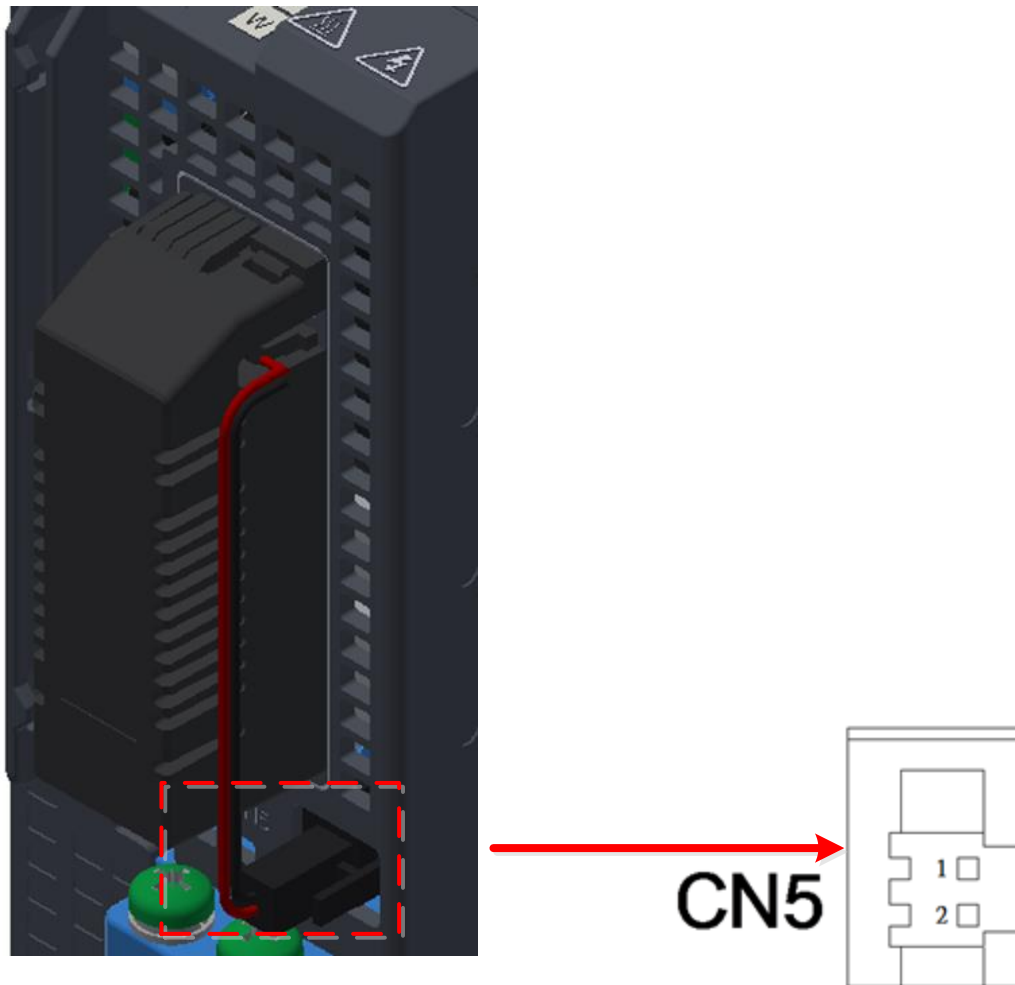

The following table shows the standard pin assignment of CN5.

Pin NO	Pin function	Function
1	Vcc(3.6V)	3.6V for battery
2	GND	3.6V ground

3.7 Standard wiring instruction



DANGER

- Only qualified engineer can do the wiring.
- The wiring must be done more than 20 minutes after the power is turned off, and the voltage must be confirmed with an electric meter, otherwise it may cause electrical shock.
- The servo drive and servo motor must be well grounded.
- Install the servo drive and motor before wiring, otherwise it may cause electric shock.
- Don't scratch or apply excessive stress on the cable, or hold it down by heavy objects.



CAUTION

- The wiring should be correct, otherwise it may cause the servo motor run unexpectedly.
- The wiring of cables and terminals should be correct, otherwise it may cause damage or abnormal operation.
- The polarity (+/-) must be correct, otherwise it may cause damage or abnormal operation.
- The polarity of the surge absorbing diode installed on the DC relay for output control cannot be reversed, otherwise the alarm signal may have no output and emergency stop protection circuit will be disabled as well.
- The electric device nearby the servo drive may have electromagnetic interference, please use the EMI suppression filter to improve.
- Don't install phase-in capacitor, surge absorber, or EMI noise suppression in the power line of the servo motor.
- When using a regenerative resistor, switch power off by regenerative abnormal signal. Otherwise, it may cause a fire due to overheated regenerative resistor.
- Do not modify the servo drive or servo motor.

3.7.1 Position control mode(Pr Mode) wiring diagram

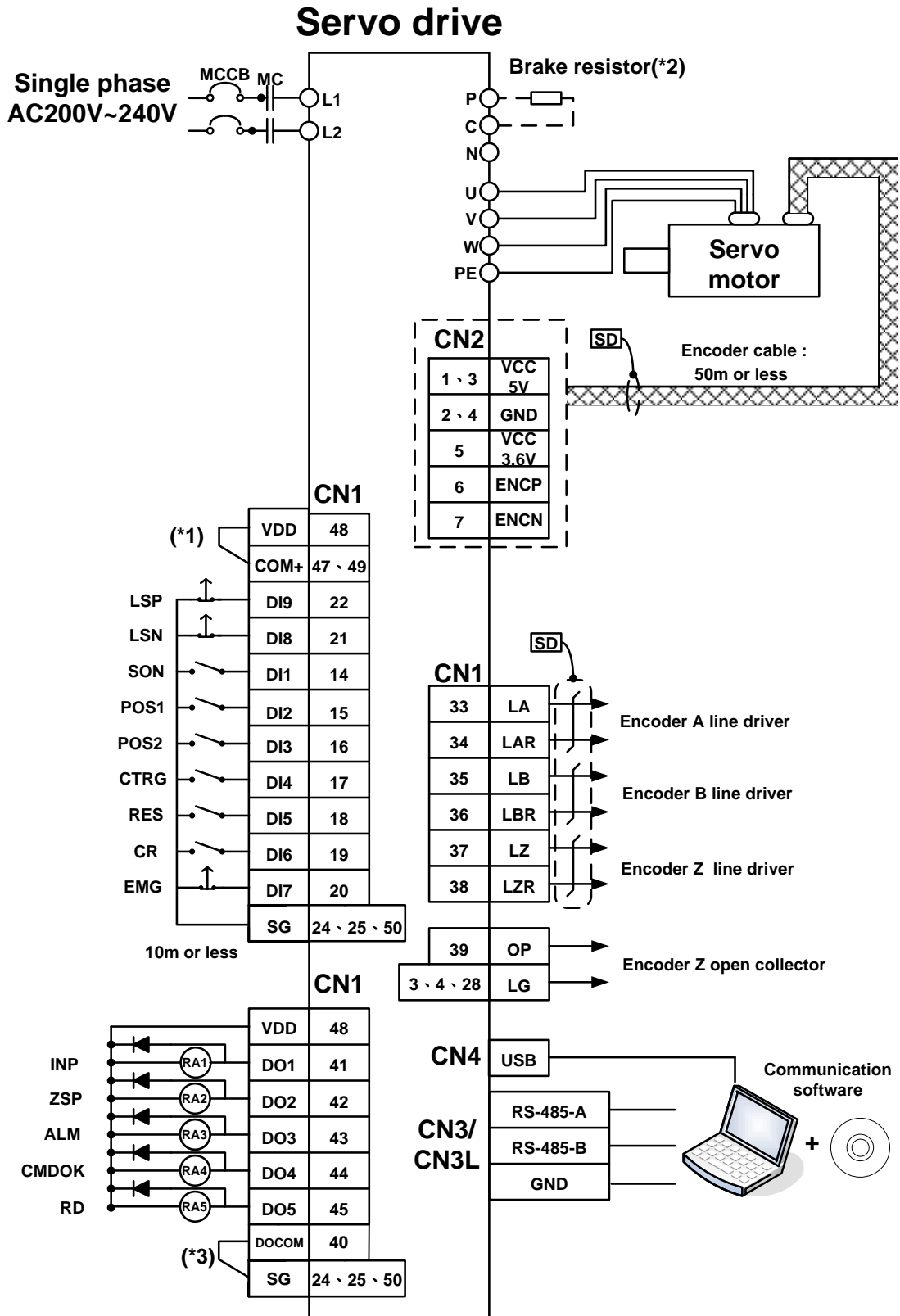

- ◆ Note: 1. If the external power is applied, do not connect VDD and COM+.
- 2. See section 3.1 for the wirings of brake resistor.
- 3. See section 3.3.6 for DO sink or source wiring

3.7.2 Position control mode(Pt Mode) wiring diagram

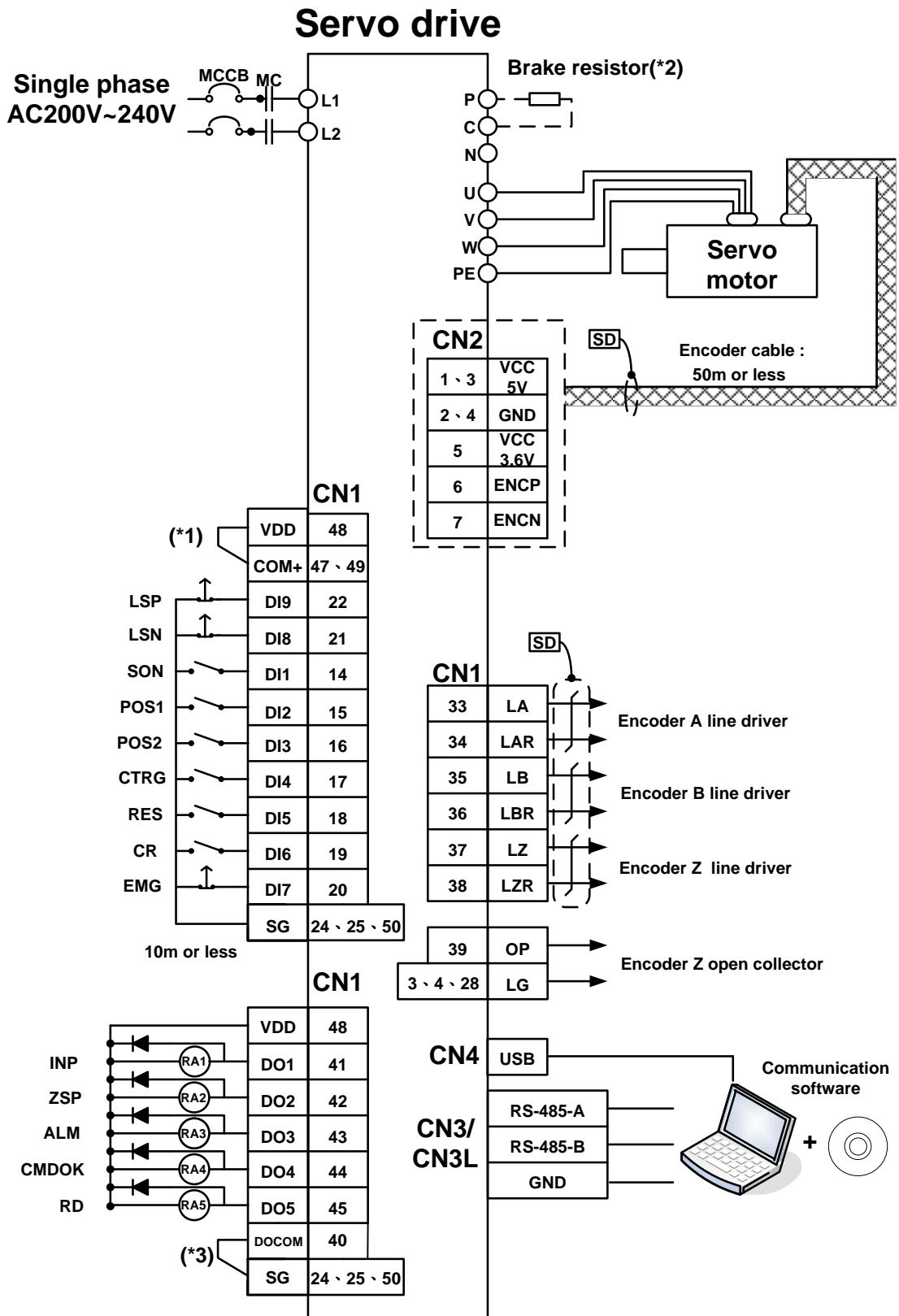

- ◆ Note: 1. If the external power is applied, do not connect VDD and COM+.
- 2. See section 3.1 for the wirings of brake resistor.
- 3. See section 3.3.6 for DO sink or source wiring

3.7.3 Speed control mode (S Mode) wiring diagram

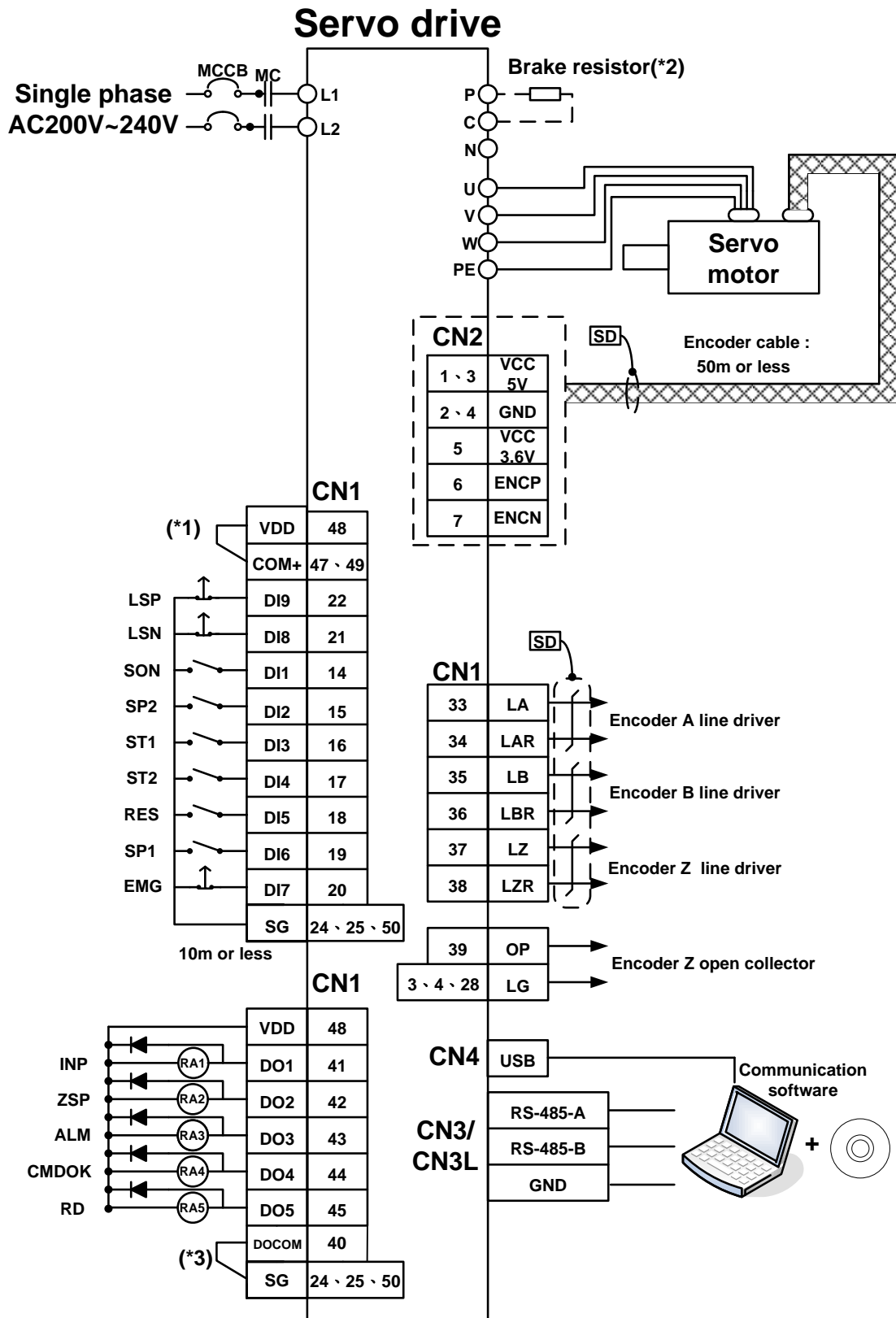

- ◆ Note: 1. If the external power is applied, do not connect VDD and COM+.
- 2. See section 3.1 for the wirings of brake resistor.
- 3. See section 3.3.6 for DO sink or source wiring

3.7.4 Torque control mode wiring diagram (T Mode)

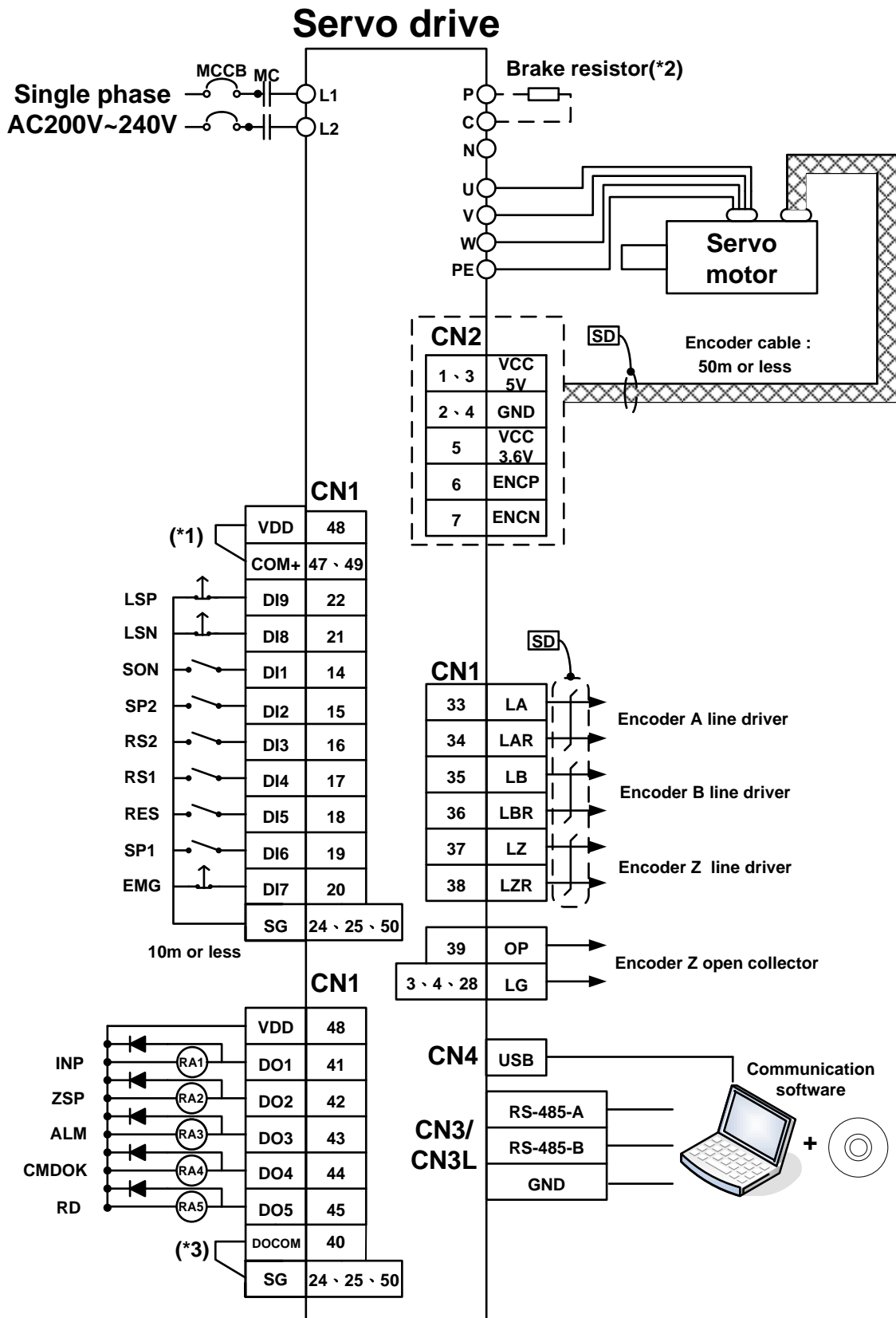

- ◆ Note: 1. If the external power is applied, do not connect VDD and COM+.
- 2. See section 3.1 for the wirings of brake resistor.
- 3. See section 3.3.6 for DO sink or source wiring

4. Panel display and operation.

This chapter describes the panel status of Shihlin Servo Drive and the operation instructions for the panel.



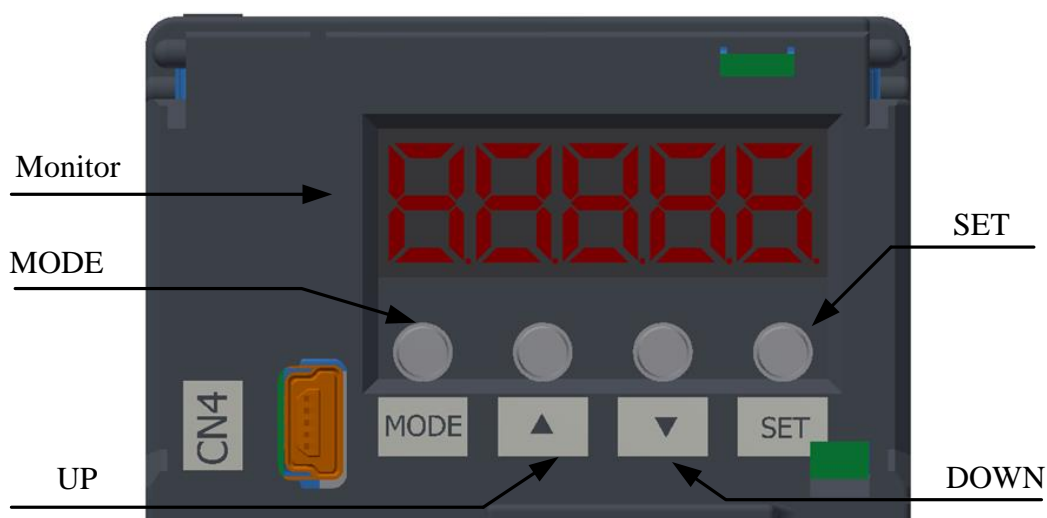



4.1 Name of each part of the panel

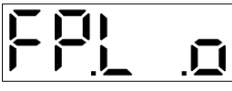

Name	Function
Monitor	Five groups of seven-segment LED are used to display monitoring values, parameter values, set values, etc.
Mode button	The key is to enter into or exit from parameter writing mode, alarm mode, monitoring mode and setting mode. This button is shift function when servo is in parameter writing mode.
UP button	This button is used to scroll up the parameter code or set value.
Down button	This button is used to scroll down the parameter code or set value.
SET button	To display and save the set value.

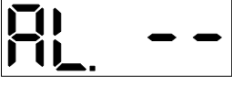
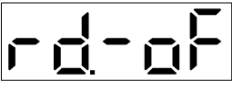
4.2 Displayed procedure

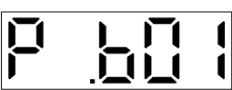
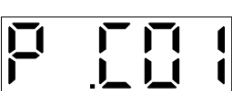
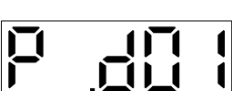
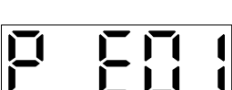
Press “MODE” key once to shift to the next display mode. Refer to section 4.4 and later for related display. To read or set the extension parameters, make them valid with the PA42 setting.

Display process	Initial Screen	Function description	Reference
Status ↓ ● MODE		Servo status display This message appears at power-on	Section 4.3
One touch ↓ ● MODE		One touch auto tuning function	Section 4.4
Alarm ↓ ● MODE		Display current alarm and history records	Section 4.5
Diagnosis ↓ ● MODE		Sequence display, external signal display, DO forced output, test operation, inertia estimated, software version display.	Section 4.6
Basic ↓ ● MODE		Display and setting of basic parameters.	Section 4.7
Gain/Filter ↓ ● MODE		Display and setting of Gain/Filter parameters.	
Extended parameters ↓ ● MODE		Display and setting of extended parameters.	
I/O setting ↓ ● MODE		Display and setting of I/O related parameters.	
Pr related parameters ↓ ● MODE		Pr mode related parameters group 1	
Pr related parameters		Pr mode related parameters group 2	



4.3 Status display

- ◆ The servo status during operation can be displayed on the 5-digit 7-segment LED display.
- ◆ Press the "UP" and "DOWN" buttons to change the content arbitrarily.
- ◆ When the power is on, select the displayable symbol and press the "SET" button to show its data.
- ◆ The 7-segment LED display can show the last 5 digits of the 16 items data such as motor rotation speed.
- ◆ If the display value is 5 digits, its negative value is displayed in 5 seven-segment display and its decimals will light up. When the display value is 4 digits or less, the negative value is on leftmost seven-segment display.

▣ **Example :**

Examples are listed in the following table:

Item	Status	Display method
		7-segment LED display
Motor rotation speed	Forward rotation at 2500r/min	
	Reverse rotation at 3000r/min	
Loaded motor inertia ratio	15.5 times	
Feedback pulse number of the motor (High 5-digit)	The value is 1234567890 High 5-digit → 12345	
Feedback pulse number of the motor (low 5-digit)	The value is 1234567890 Low 5-digit → 67890.	

Parameter writing completed	Write successfully	
Parameter writing failed	Writing fail when servo is on(SON on)	 Rewrite after turning the SON off.
Parameter writing value is out of range	Parameter writing value is out of range	 Rewrite parameter setting value.

PS : For detailed numerical display of panel data, please refer to the parameter numerical display example in section 4.7.

Note: When setting the panel parameters, each parameter has the upper and lower limits.

- (a) When the decimal data is modified, the modification should be within the upper and lower limits.
- (b) When the hexadecimal data is modified, each Hex value has its upper and lower limits.

▣ **Status overview**

The servo status are as follows:

Status	symbol	Unit	Content	Range
Feedback pulse number of the motor (High 5-digit) (before E-Gears)	FPH. I	pulse	Feedback pulse number of the motor (High 5-digit) (before E-Gears) Ex : if feedback pulse number is 123456789 pulse, 1234 is displayed. Note1	-21474~ 21474
Feedback pulse number of the motor (low 5-digit) (before E-Gears)	FPL. I	pulse	Feedback pulse number of the motor (low 5-digit) (before E-Gears) Ex : if pulse number is 123456789 pulse, 56789 is displayed.	-99999~ 99999

			Note1	
Pulse number of pulse commands input (High 5-digit) (before E-Gears)	CPH. I	pulse	Pulse number of pulse commands input (High 5-digit) (before E-Gears) Ex : if command pulse number is 123456789 pulse, 1234 is displayed. Note1	-21474~ 21474
Pulse number of pulse commands input (low 5-digit) (before E-Gears)	CPL. I	pulse	Pulse number of pulse commands input (low 5-digit) (before E-Gears) Ex : if command pulse number is 123456789 pulse, 56789 is displayed. Note1	-99999~ 99999
Deviation pulse number (before E-Gears)	E. I	pulse	Pulse command input and feedback pulse deviation number (before E-Gears) Since the display can only shows 5 digits, it shows the actual last 5 digits	-99999~ 99999
feedback pulse number of the motor (High 5-digit) (after E-Gears)	FPH. O	pulse	Feedback pulse number of the motor (High 5-digit) (after E-Gears) Ex : if feedback pulse number is 123456789 pulse, 1234 is displayed. Note1	-21474~ 21474
Feedback pulse number of the motor (low 5-digit) (after E-Gears)	FPL. O	pulse	Feedback pulse number of the motor (low 5-digit) (after E-Gears) Ex : if pulse number is 123456789 pulse, 56789 is displayed. Note1	-99999~ 99999

Pulse number of pulse commands input (high 5-digit) (after E-Gears)	CPH. O	pulse	Pulse number of pulse commands input (high 5-digit) (after E-Gears) Ex : if command pulse number is 123456789 pulse, 1234 is displayed. Note1	-21474~ 21474
Pulse number of pulse commands input (low 5-digit) (after E-Gears)	CPL. O	pulse	Number of pulse commands input (low 5-digit) (after E-Gears) Ex : if command pulse is 123456789 pulse, 56789 is displayed. Note1	-99999~ 99999
Deviation pulse number(after E-Gears)	E. O	pulse	Deviation number of pulse command input and feedback pulse (before E-Gears) Since the display can only shows 5 digits, it shows the actual last 5 digits	-99999~ 99999
Pulse command input frequency	CPF	kHz	Input frequency of external pulse command	-6000~ 6000
Current speed of motor	r	rpm	show the current motor feedback speed	-6000~ 6000
Analog speed command/ voltage limit	F	V	(1) In speed control mode, no analog input function and it shows 0. (2) In torque control mode, no analog input function and it shows 0.	-10. 00~ +10. 00
Speed input command/limit	V	rpm	In speed control mode, it indicates analog input speed command. In torque control mode it indicates speed limit	-6000~ 6000
Analog torque command/ voltage limit	U	V	No analog input function in position control mode and speed control mode, and it shows 0.	0 ~ +10. 00

			No analog input function in torque control mode, and it shows 0.	-10.00~ 10.00
Torque input command/limit	TC	%	In position control mode and speed control mode, it indicates torque limit , shows as TC.	0~ 300
			In torque control mode, it shows the torque command.	-300~300
Effective load rate	J	%	It indicates the load rate of continuous torque, which shows the effective load value by taking the rated torque as 100%	0~ 300
Peak load rate	b	%	It indicates the maximum torque peak that ever occurred, which shows the highest value in the past 15 seconds by taking the rated torque as 100%	0~ 300
DC bus voltage	Pn	V	It indicates the voltage between P-N of main circuit. "Lo-dC" is shown if it is less than normal value.	0~500
Load to motor inertia ratio	dC	times	The load to servo motor inertia ratio is displayed.	0.0~300. 0
Instantaneous torque	T	%	It indicates the Instantaneous torque value and takes the rated torque as 100%, the generated torque is showed in Real time.	0~100
Regenerative load ratio	L	%	it shows permissible percentage of regenerative power.	0~100

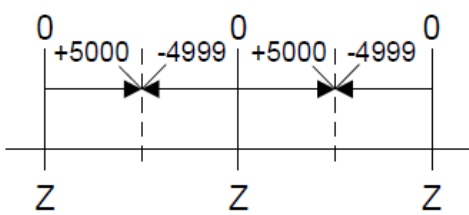
The absolute pulse number relative to encoder Z phase	ZP	pulse	<p>The absolute pulse number of encoder Z phase, which the value in the origin is 0, and its coordinate is set to plus or minus 5000 pulse respectively, as shown in the figure below:</p> 	<p>-4999 ~ 5000</p>
---	----	-------	---	-----------------------------

Note 1: When the panel is showing the numerical data, if press the SET key, pulse number of pulse commands input (before or after E-Gears), feedback pulse number, and pulse deviation will be cleared, and this definition is same as the content of communication address 0x0951.

▣ **Change of status on display**

By changing PA01, the 7-segment LED status display items can be changed when the power is on. The initial status display items are changed as follows according to the control mode.





Control mode	Item
Position	Feedback pulse number of the motor (low 5-digit)
Position/speed	Feedback pulse number of the motor (low 5-digit)/current speed of motor
Speed	Current speed of motor
Speed/torque	Current speed of motor / torque command
Torque	Torque command
Torque/position	Torque command/ feedback pulse number of the motor (low 5-digit)



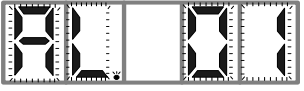

4.4 One-touch Tuning Function

Name	Display	Description
One-touch Tuning		You can perform One-touch Tuning in this screen display. Refer to 5.3.2 for more details.

4.5 Alarm mode

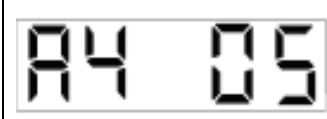
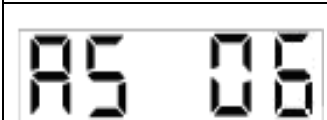
It indicated alarm and alarm record. The last 2 digits show the Alarm NO.

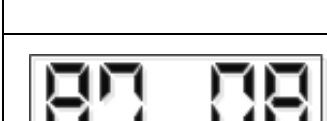
Name	Display	Description
Current alarm		No alarm occurs.
		The screen will blink when an over-voltage alarm occurs(AL.01).
Alarm record		The last alarm in the past is Over-voltage (AL.01).
		The 2nd alarm in the past is Low voltage(AL.02).
		The 3rd alarm in the past is Over current(AL.03).
		The 4th alarm in the past is Regenerated abnormal (AL.04).

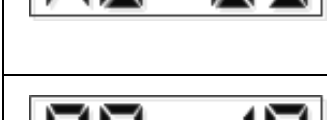
	The 5th alarm in the past is Overload(AL.05).
	The 6th alarm in the past is Over speed(AL.06).
	The 7th alarm in the past is Abnormal pulse control (AL.07).
	The 8th alarm in the past is Excessive deviation of position(AL.08).
	The 9th alarm in the past is Serial communication error (AL.09).
	The 10th alarm in the past is Overload 2(AL.10).

Function when alarm occurs

A: the screen can shows the current alarm no matter which mode the servo is in.

B: Other screens can still be read when an alarm occurs, and its fourth LED decimal point will blink(count from the right side).







C: the alarm can be cleared by following method when the root cause is eliminated

- (a). Restart the power.
- (b). press SET button in current alarm screen.
- (c). turn on the reset signal(RES).

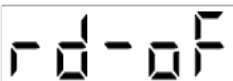
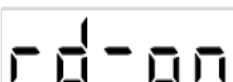
D. Use "UP" "DOWN" to scroll down to the next history record.

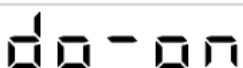
4.6 Diagnostic mode

Shihlin servo diagnosis mode operation shows in the following table.

Name	Display	Description
Control status		Servo is not ready yet, The drive is under initializing, alarm occurs or the SON terminal is OFF.
		Servo is ready. When servo is ON and ready for operation.
External I/O signal indication		It indicates the ON/OFF status of external input/output signals. The upper part of each segment shows the input signal, and the lower part shows the output signal. The input/output signal can be defined by PD group related parameters.
DO forced output		Digital output signal can be forced ON/OFF.
Test operation mode		When there is no command from an external device, JOG operation can be executed.
Test position operation		When there is no command from an external device, one time positioning operation can be done. This function will disable panel operation, and you can connect to the communication software and perform test by RS-485/USB.
Test and estimate inertia analysis operation		This function can perform automatic estimation of load inertia ratio and automatic estimation of related gain values, It will disable panel operation, you can connect to the communication software and perform test by RS-485/USB.

Factory test only.		
Software version(Low)	SE-A2	It indicates the version series of SERVO software.
Software version(High)	200-0	It indicates the version number of the SERVO software.

The use of the diagnosis mode will introduce in detail as follows.

4.6.1 External I/O signal indicator.

This is to verify the ON/OFF states of SERVO AMP digital I/O signals.

(1) Operation

It indicates the screen of the display after power-on, and press the “MODE” key to go to the diagnostic screen.

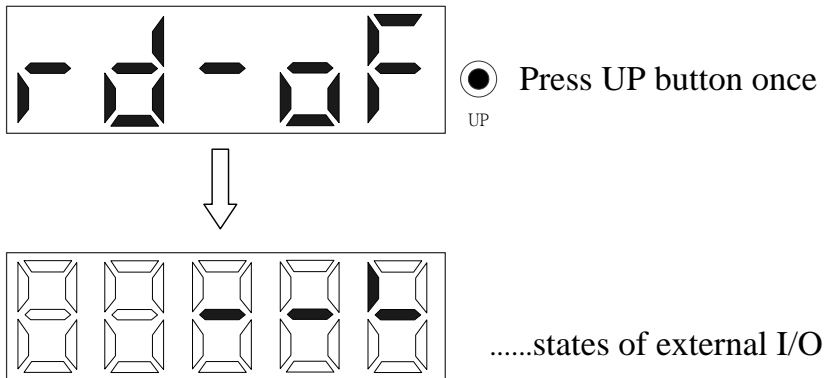

(2) Display content

Display of I/O pin definition.

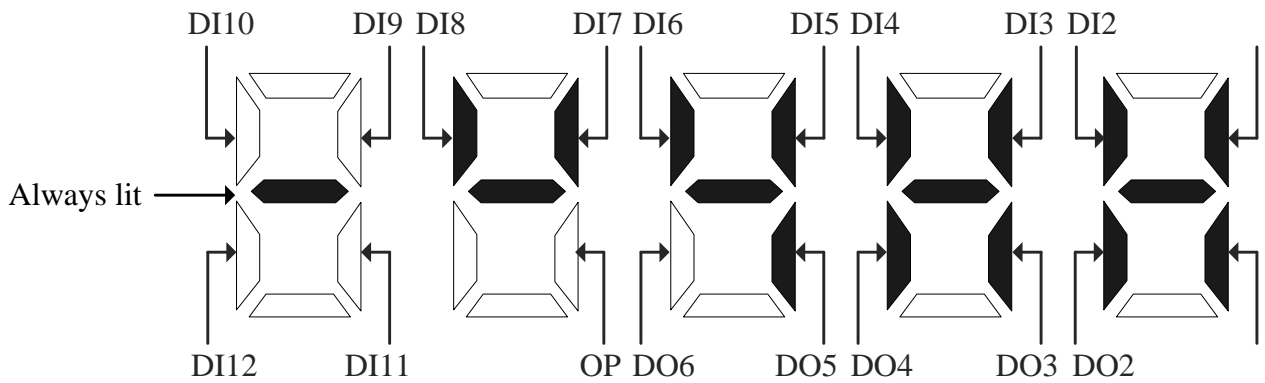

Display ON/OFF with 7-segment LED.

The upper part of each segment is the input signal (DI1~DI10), and the lower part is the output signal (DO1~DO6, OP) and the input signal DI11, DI12. Take the above picture as example, DI1~ DI8, DO1~DO5 are in ON status, DI9~DI12 ,DO6 and OP are in OFF status.

4.6.2 Forced output (DO forced output)

It can force ON/OFF the output signal without impacting the SERVO status. This function can be used for wiring inspection on output signal, etc.

- ★ To confirm that no alarm occurs and no external command received.
- ★ Ensure that SON and SG contacts are open when testing.

Operation

It indicates the screen of the display after power-on, press the "MODE" key to go to the diagnostic screen:

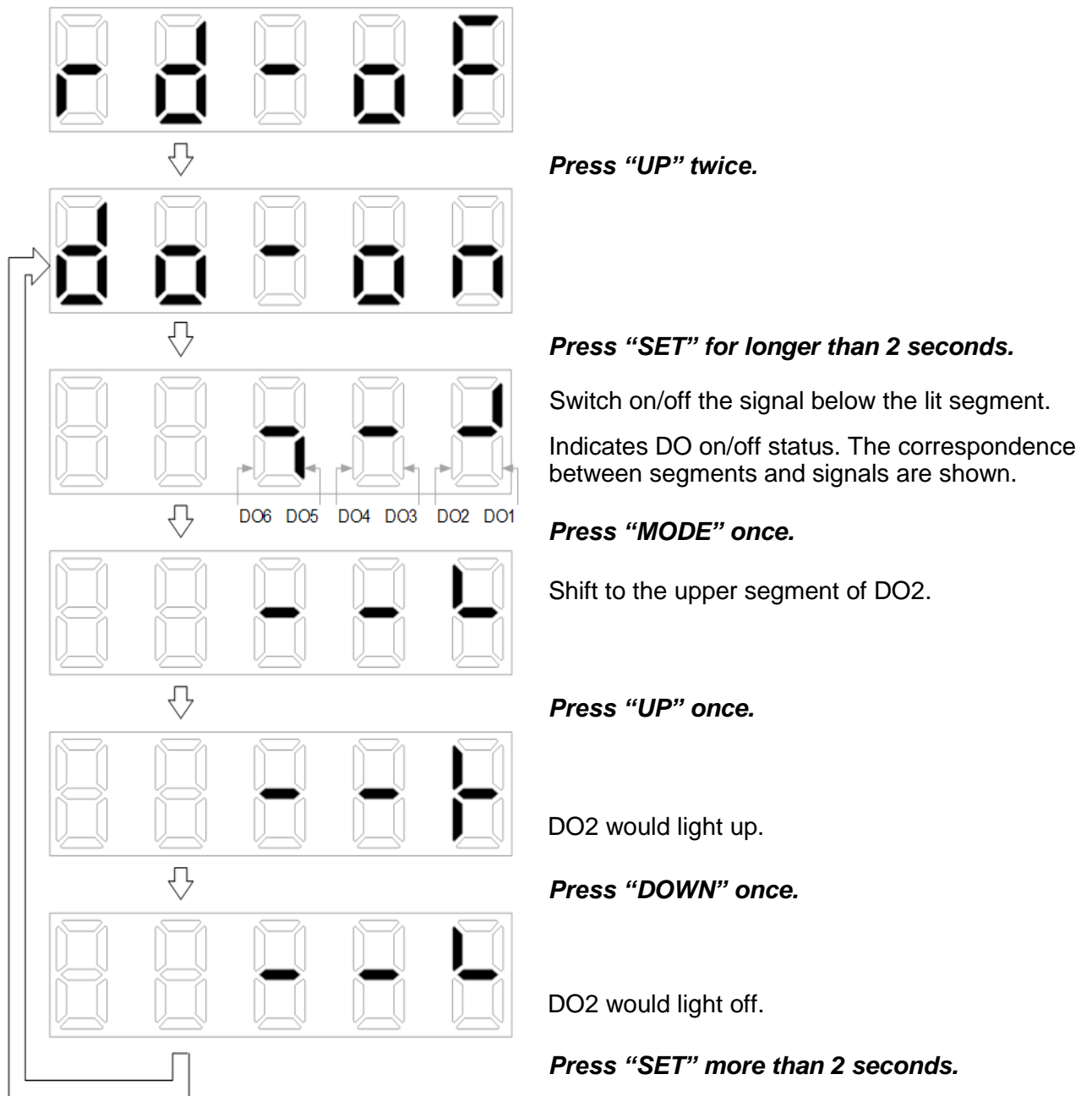

4.6.3 JOG operation

- ★ JOG operation can be performed after confirming no alarm or warning message in the servo.
- ★ Ensure that SON and SG contacts are open when testing.
- ★ Ensure that EMG, LSP, LSN are on , and if CN1 has no external wiring, you can perform this function by setting PD01.

Set JOG speed command by PC04, and set the acceleration time constant by PC01 and the deceleration time constant by PC02. Below picture shows the display screen after power-on. Please select JOG operation, test positioning operation, test estimation inertia analysis operation in following sequence and press the "MODE" button to go to the diagnosis screen.

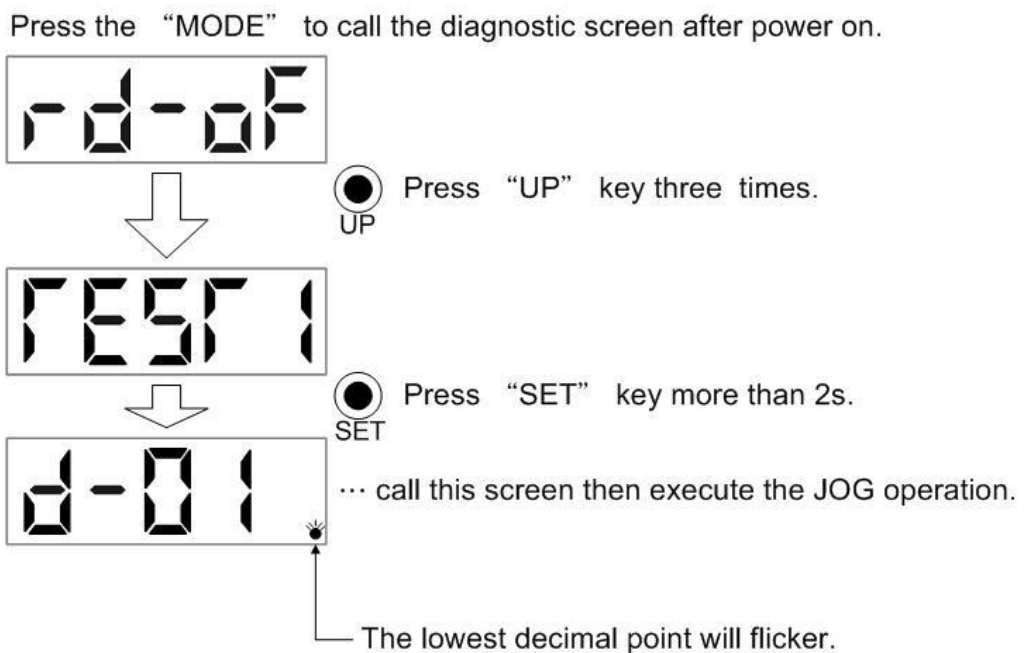

(1) Operation and Running.

To perform JOG operation, it's necessary to short the circuit between VDD and COM+ if internal power supply is used between EMG-SG, press and hold the "UP" "DOWN" button to start the servo, and release it to stop. The setting is described in the following table:

Item	Set value	Default value	Setting range
Rotate speed [r/min]	PC04	300	0~6000
Acceleration and deceleration time	PC01, PC02	200	0~20000

Note: The JOG speed setting value of the panel is set by PC04.

Button description is as below:

Button	Content
"UP"	Press and hold UP button to run in the CCW direction. Release it to stop.
"DOWN"	Press and hold DOWN button to run in the CW direction. Release it to stop.

(2) Status display

SERVO status during JOG operation can be confirmed.

If you press the "MODE" button while JOG is in operation, the status screen is displayed. In this status screen, you can use "UP" "DOWN" button to execute JOG operation. Each time you press the "MODE" button, it moves to the next screen and back to the JOG operation screen after one turn. Refer to section 4. 3 for status display details.

The "UP" and "DOWN" buttons cannot be used to change the status in JOG operation mode.

(3) Exit JOG operation

During JOG operation, you can turn off the power once or press and hold the "SET" button for more than 2 seconds in the test operation screen to exit the JOG operation,



Please refer to the description of step 3 in section 5.2.1 to understand how to use Shihlin servo PC software to operate the JOG function.

4.6.4 Test positioning operation

- ★ To activate test positioning operation, the servo must connect to the Shihlin communication software via RS-485 or USB.
- ★ Test positioning operation can be performed when it is confirmed that there is no external command device and no alarm message from servo.
- ★ Ensure SON is OFF before test.
- ★ The motor will stop suddenly if the communication cable falls off during operation.
- ★ When the communication software enters the test positioning mode, the panel is showing the following figure:

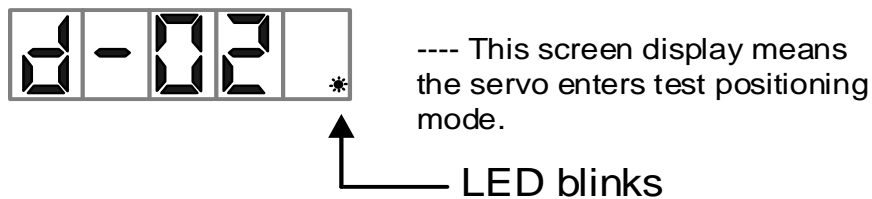

Refer to section 5. 2. 2 for detailed test positioning operation instruction.

4.6.5 Inertia estimation and tuning by communication software

- ★ To activate test positioning operation, the servo must connect to the Shihlin communication software via RS-485 or USB.
- ★ Test positioning operation can be performed when it is confirmed that there is no external command device and no alarm message from servo.

Operation. Running

When using inertia estimation operation, ensure the motor is correctly wired and select Automatic Gain Adjustment function in Shihlin communication software.

The instruction for auto-gain adjustment function is as follows:

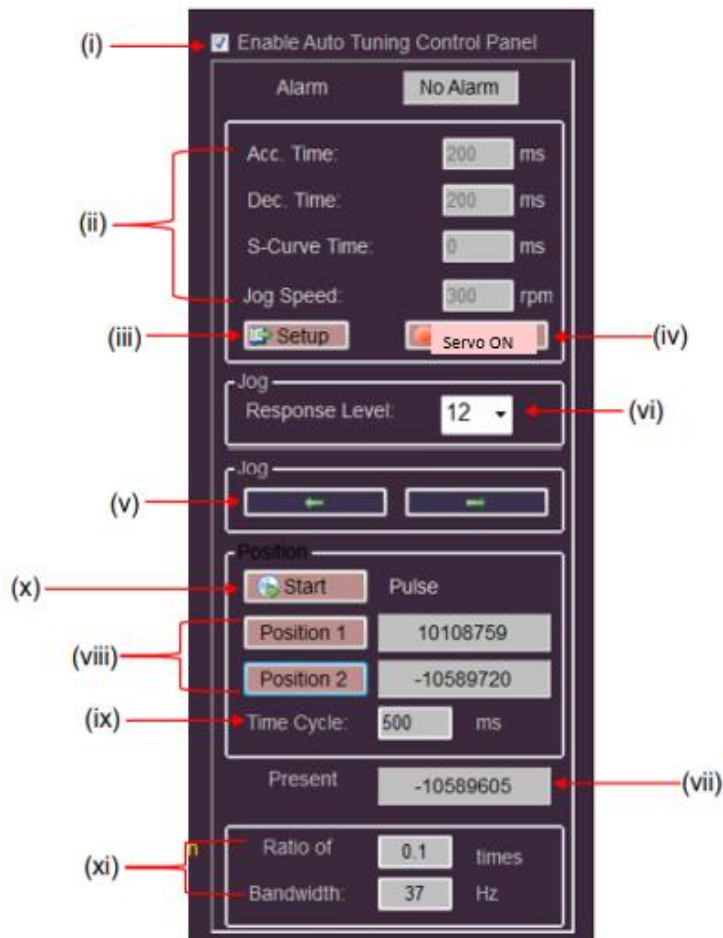

- (i) Click [Enable Auto Tuning Control Panel].
- (ii) Set speed acceleration time, deceleration time, S-curve acceleration and deceleration time and JOG speed.
- (iii) If no alarm occurs, Click [Setup] to write the setting value of step (2) to the drive.
- (iv) Click [Servo ON] and the servo motor will be ON.
- (v) Press \leftarrow button to rotate the motor reversely. Release it to stop the motor.
- (vi) Press JOG \rightarrow to rotate the motor forwardly. Release it to stop the motor.
- (vii) To perform the response setting. The larger the value, the stronger the gain, which has the same function as PA03.
- (viii) To show the current feedback position of the motor.
- (ix) To control the motor to run forwardly or reversely. After the motor reaches the first target position, press position 1 and then press JOG, Set position 2 when the motor is in the 2nd target position, and the software will record the 2 target position.

- (x) The time interval is the static time of each positioning stops.
 - (xi) After setting target position 1 and target position 2, and time interval, Press [Start] (S) and motor runs between Position1 &2 cyclically.
 - (xii)After the motor runs a few operation cycles, the current “load inertia ratio” and “bandwidth”value will be estimated.
 - (xiii)To display the current alarm status. If there is no alarm, it shows No Alarm, if there is an alarm, it shows the current alarm number.
- Caution
 - (1)You can directly set the response in the response setting menu if the response is not enough during operation, but it is recommended not to set the response too high instantly, and it should increase gradually.
 - (2)To judge whether the load inertia ratio has converged or the machine features have satisfied the customer’s requirement, you can press stop to complete the preliminary inertia estimation and gain adjustment.
 - (3)You can cancel the automatic gain control panel option or close the window form directly to exit. At this time, the PC software writes the estimated load inertia ratio and response setting values to PB06 and PA03 respectively.

The servo calculates the best gain value automatically after the gain is estimated. The following table is the estimate item.

Name	Parameter abbreviation	Parameter code	Setting range	Unit	Default value	Control mode
Resonance suppression low-pass filter	NLP	PB03	0~10000	0.1ms	17	Pt, Pr, S, T
Position feed-forward gain value	FFC	PB05	0~200	%	0	Pt, Pr
Servo motor Load inertia ratio	GD1	PB06	0~1200	0.1 times	70	Pt, Pr, S
Position loop gain	PG1	PB07	4~1024	rad/s	45	Pt, Pr
Speed loop gain	VG1	PB08	40~9000	rad/s	183	Pt, Pr, S
Speed integral gain value	VIC	PB09	1~1000	ms	34	Pt, Pr, S

- ★ When the communication software enters the inertia estimation mode, the panel display the following figure:

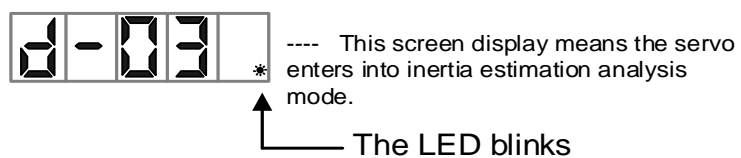

4.7 Parameter mode

4.7.1 16 bit parameter setting instruction

After changing the settings, some parameters are activated after restart the power.

(1) Operation instruction

The following is an example to illustrate the operation method after restarting when the control mode (PA01) is changed to the speed control mode.

Example 1: control mode(PA01)changes to speed control mode.

Press "MODE"button and enter PA01 parameter screen display.



Indicates PA01

⊙
UP ⊙
DOWN Press UP or down button to change PA01

⊙
SET Press SET button twice



The rightmost parameter shows on the LED keeps blinking

⊙
UP Press UP button twice



Change the setting value during blinking

⊙ ⊙
UP DOWN Use UP Down button to change the setting

⊙
SET press SET button to activate the setting



Parameter setting is completed

Press "UP DOWN" to scroll down to next parameter.

If PA01 is changed, you must restart the power to activate the setting after the setting is changed.

- The MODE key converts to Shift function when setting the parameters.

Next section will introduce how to use the "MODE" "UP" and "DOWN" buttons to operate.

4.7.2 32 bit parameter setting instruction

- Decimal parameter reading and writing method (positive number)

Example: PA19 is 1234567, then to change to 1434567.



Press "SET" once.



The lower 5 digits of PA19 are shown and the lowest decimal point indicates that this is low screen.

Press "MODE" once



The higher 2 digits of PA19 are shown and the second decimal point indicates that this is high screen.

Press "MODE" once



The screen is returned to the low screen.

Press "SET" once

The lowest digit display would be flickering.

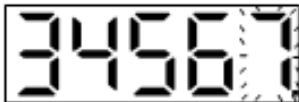

Press "MODE" for 5 times.



The flickering digit would shift left to the second high digit.

Press "UP" twice.

The flickering digit would be changed to "4".

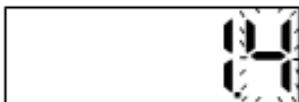

Press "SET" once to store the modification.

● Decimal parameter reading and writing method (negative number)

Example: PA19 is 1234567, then to change to -1434567.



Press "SET" once.



The lower 5 digits of PA19 are shown and the lowest decimal point indicates that this is low screen

Press "MODE" once.



The higher 2 digits of PA19 are shown and the second decimal point indicates that this is high screen.

Press "SET" once.



The lowest digit of this screen would be flickering.

Press "MODE" twice.



The flickering digit shifts to the highest digit and the "-" sign appears.

Press "SET" once.



This screen will show "-1.2".The PA19 is -1234567 now.

Press "MODE" once.

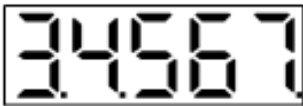

Return to the screen of -1234567 lower 5 digits. The left 2 decimal points indicate that this number is negative.

Press "UP" once.

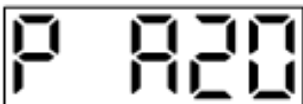

Scroll to the next parameter. (PA20)

● Hex parameter reading and writing method

Example: PE01 is 0x3760135 and then to change to 0x03740135.



Press "SET" once.



The lower 4 digits of PE01 are shown and the underline of highest digit indicates that this is low word.

Press "MODE" once.



The higher 4 digits of PE01 are shown and the up segment of highest digit indicates that this is high word.

Press "MODE" once.



It shows the lower word again.

Press "SET" once.

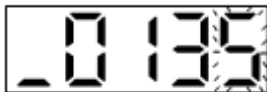

The lowest digit of PE01 would be flickering.

Press "SET" 4 times.



This flickering digit shifts to the lowest digit of high word.

Press "DOWN" twice.



The display shows the modification.

Press "SET" once to store the modification.

5. Running Operation

5.1 Check items Before Operation.

Check carefully on below listed items before the motor runs to avoid unnecessary damage to the motor.

- ◆ Check if the power terminals (L1, L2) of the servo drive are wired correctly.
- ◆ Servo motor power terminals (U, V, W) and U, V, W wiring phases on the servo drive must be consistent.
- ◆ Check if the ground terminal of the servo drive is correctly grounded.
- ◆ Check if there is any conductive material or inflammable material inside or near the drive.
- ◆ Check if the voltage of power supply is correct.
- ◆ Check if the control switch is OFF.
- ◆ Do not put heavy staff on the driver or wiring.
- ◆ Use twisted wire when wiring the regenerative resistor.
- ◆ Check if the appearance of the drive is obviously damaged.



DANGER

- Do not operate the switch with wet hands, otherwise it may cause electric shock.



CAUTION

- Check each parameter before running. Otherwise, there may be unexpected actions occurs.
- The heat sink, regenerative resistor, servo motor, etc. may in a high temperature during power-on or in a short time after power off. Do not touch it to avoid burns.

5.2 No-load test

During the no-load test, first remove all loads connected to the servo motor (such as the unit or the coupling of the servo motor shaft or related accessories, etc.). After that, if the servo motor runs normally according to the normal operation procedure, you can connect the load back. The following will explain the test of the motor when there is no load.

5.2.1 No-load JOG test

- ★ JOG operation can be performed after confirmed no alarm or warning message in servo.
- ★ Ensure that SON and SG contacts are open when testing(SON OFF).
- ★ Ensure that EMG, LSP, LSN are on , and if CN1 has no external wiring, you can perform this function by setting PD01.

No-load JOG operation can be operated by the drive panel together with Shihlin communication software, this is to confirm whether the speed of motor and direction of rotation are as expected. You cannot modify the motor speed during JOG operation by the panel. If you must to modify it, you can do with Shihlin communication software via RS-485 or USB transmission. and it is recommended to perform JOG operation at a low speed. The following uses the panel operation mode to explain the JOG operation procedure.

Step 1: After the servo drive and the servo motor are connected correctly, switch on the servo drive.

Step 2: Use the "MODE" button on the panel to enter the diagnosis screen and press the UP button 3 times to enter TEST1 (JOG mode). At this time, press and hold SET button for 2 seconds to switch to d-01. screen (JOG operation).

Press the "MODE" to call the diagnostic screen after power on.

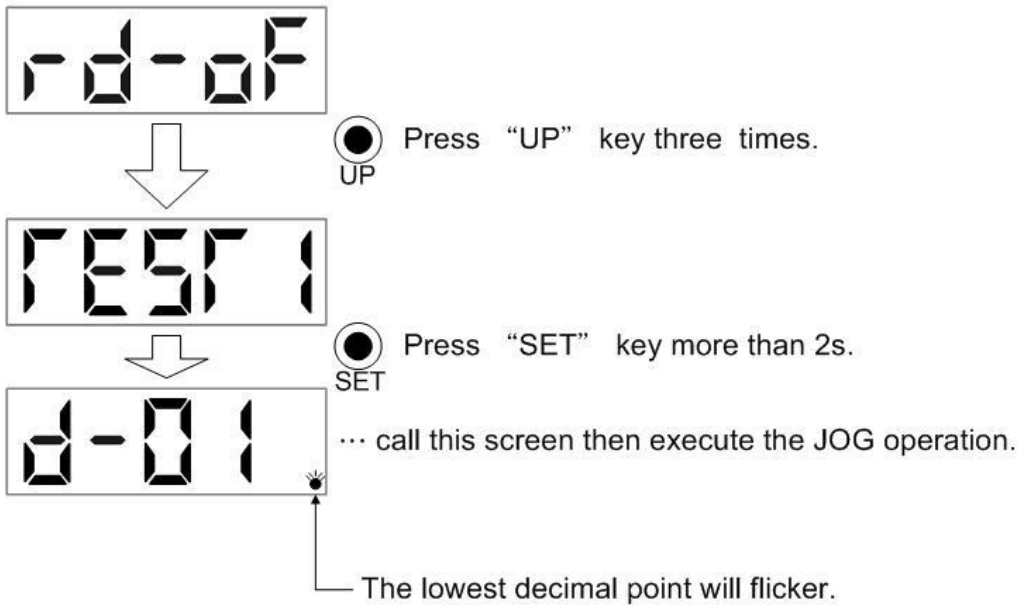

Step 3: During JOG operation, when pressing the "UP" or "DOWN" button, the servo motor will rotate in the CCW or CW direction. Motor will stop when release the button, and you can set PC04 to modify the JOG operation speed.

When using Shihlin communication software to perform JOG operation, the setting value and range of operation are as follows:

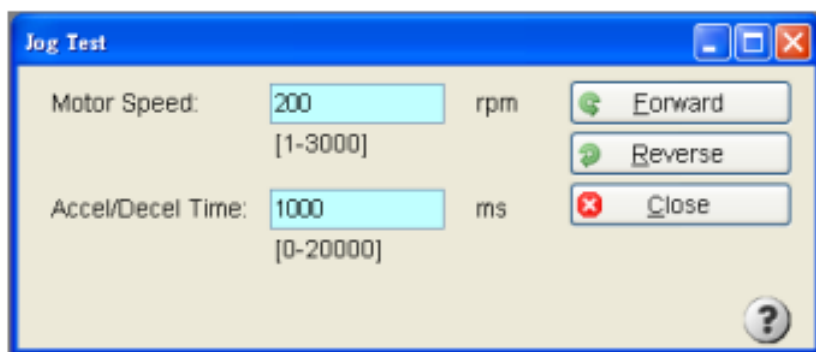

Note: When using the communication software for JOG operation, if the communication cable is disconnected during operation, the servo motor will decelerate to stop.

The button description as follows:

button	Content
Forward rotation	Press the button and runs the motor in CCW
reverse rotation	Press the button and runs the motor in CW
Finish	To finish JOG test.

Step 4: If the JOG operation is finished, turn off the power once or hold the "SET" button for more than 2 seconds in the test operation screen (d-01.) to exit the JOG operation mode.



5.2.2 No-load positioning test

For no-load positioning operation, please use RS-485 or USB to connect to Shihlin communication software. In order to confirm whether the speed and direction of rotation are as expected, it is recommended this operation is performed at a low speed. The positioning operation needs to set the number of revolutions and pulses. For example, as the motor rotate 1 circle takes 17-bit pulse (that is 131072 pulse), to set 10 and 1/2 circles, the wave number should set as 1376256 pulse. The following explains the use of positioning operation:

Step 1: After the servo drive and the servo motor are connected correctly, switch on the servo drive.

Step 2: Connect the computer and the CN4 terminal of the servo drive with a standard Mini USB cable. Select the USB communication and the correct address after connecting the Shihlin communication software.

Step 3: Select "Test"/"Positioning Test" on the top of the communication software and enter the positioning test screen.

Step 4: To perform positioning operation, first need to set the number of revolutions and pulses. If press the Forward Rotation button, servo motor will run in the CCW direction to the target number of revolutions and pulses. and if press Reverse Rotation button, the servo motor will run in the CW direction to the target number. The initial condition and setting range are as follows:

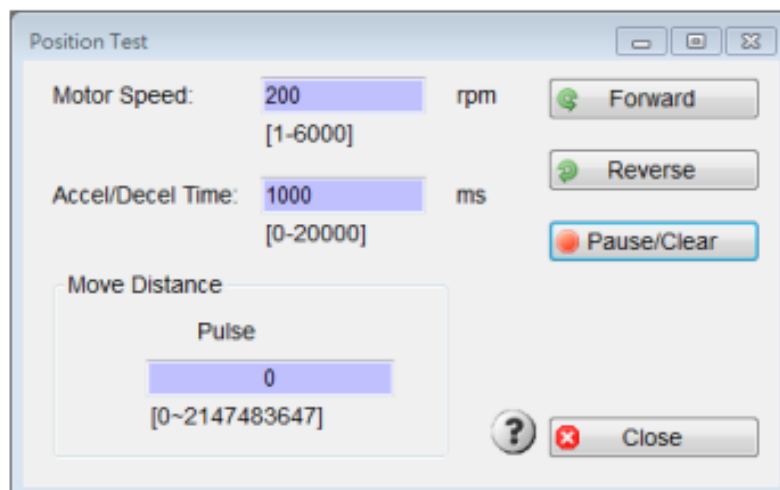

Description of button as below:

Button	Function
"UP"	Press it once , it will run the motor in CCW direction until reaches target number of revolutions and pulse number
"DOWN"	Press it once and it will run the motor in CW direction until reaches target number of revolutions and pulse number.
Suspend/clear	<p>Press it once, the motor will stop temporarily if the motor does not reach the target number of revolutions and pulses, and the motor will run the remaining number of revolutions or pulses if operation is enabled.</p> <p>If you press twice on suspend button, the remaining number of revolution or pulse is cleared.</p>
Close	Positioning test finished.

Step5: when positioning operation is finished, press the CLOSE button to exit.

5.3 Tuning procedure.



CAUTION

●Don't do extremely adjustment and change of parameters, which will cause unstable operation.

5.3.1 Tuning method and type

With the auto gain adjustment function, the load inertia can be estimated quickly and accurately, and the appropriate servo gain of the motor under different loads can also be quickly searched. If the auto gain adjustment mode cannot meet the user's requirement, manual adjustment mode can be used.

The gain adjustment mode are as follows:

Tuning mode	PA02 Parameter setting	Load inertia estimation method	Auto-estimate parameters	User-defined parameters
Manual gain adjustment mode(PI control)	0000 0001	Fixed as value of PB06		GD1(PB06) PG1(PB07) VG1(PB08) VIC(PB09)
Auto- gain adjustment mode 1	0002	Continuously estimation	GD1(PB06) PG1(PB07) VG1(PB08) VIC(PB09)	ATUL(PA03)
Auto-gain adjustment mode 2	0003	Fixed as value of PB06	PG1 (PB07) VG1 (PB08) VIC (PB09)	ATUL(PA03) GD1(PB06)
Interpolation mode 1	0004	Continuously estimation	GD1(PB06) VG1(PB08) VIC(PB09)	ATUL(PA03) PG1 (PB07)
Interpolation mode 2	0005	Fixed as value of PB06	VG1 (PB08) VIC (PB09)	ATUL(PA03) GD1(PB06) PG1 (PB07)

- ★ PA02 cannot be written when SON-SG is short-circuited, please open-circuit SON-SG before setting.

Please refer to the below table for recommendations on the tuning sequence and mode.

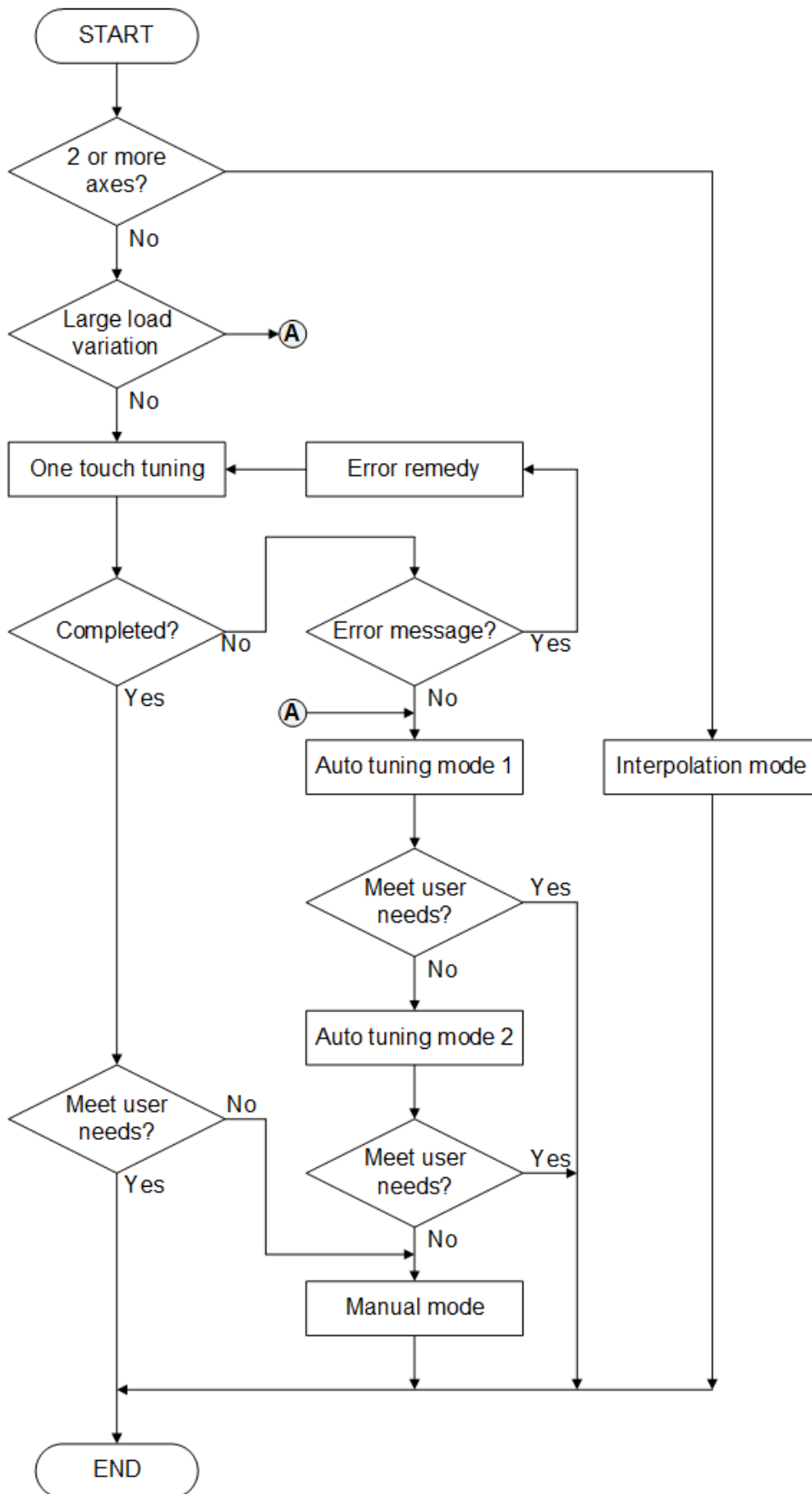

If the servo is in first use, it need run in JOG mode first to confirm no abnormal issue, after that you can use the auto-tuning function. To estimate the inertia ratio and search bandwidth, it is necessary to generate acceleration and deceleration commands for several rounds and make the inertia ratio estimation runs in a steady state.

5.3.2 One-touch Tuning Function

The one-touch gain tuning function can be performed by communication software or the panel. The related parameters that can automatically set by the one-touch tuning function are shown in the table below:

Parameter NO	parameter abbreviation	Parameter name
PA03	ATUL	Auto-tuning response level setting
PB01	NHF1	Frequency of machine resonance suppression filter 1
PB02	NHD1	Machine resonance suppression attenuation 1
PB03	NLP	Time constant of Resonance suppression low-pass filter
PB06	GD1	servo motor Load inertia ratio
PB07	PG1	Position loop gain
PB08	VG1	Speed loop gain
PB09	VIC	Speed integral gain
PB21	NHF2	Frequency of Machine resonance suppression filter 2
PB22	NHD2	Machine resonance suppression attenuation 2
PB27	ANCF	Auto resonance suppression mode
PB28	ANCL	Resonance suppression detection level
PB29	AVSM	Auto vibration suppression mode
PB30	VCL	Low-frequency vibration detection level
PB31	VSF1	Vibration suppression frequency 1
PB32	VSG1	Vibration suppression gain 1
PB33	VSF2	Vibration suppression frequency 2
PB34	VSG2	Vibration suppression gain 2
PB35	FRCL	Friction compensation level
PB36	FRCM	Friction compensation smoothing time constant
PB45	NHF4	Frequency of Machine resonance suppression filter 4
PB46	NHD4	Attenuation rate of Machine resonance suppression filter 4

5.3.2.1 One touch tuning function process.

One touch tuning function is simple and it has 2 ways to operate. In addition, it must be performed when the servo system runs normally.

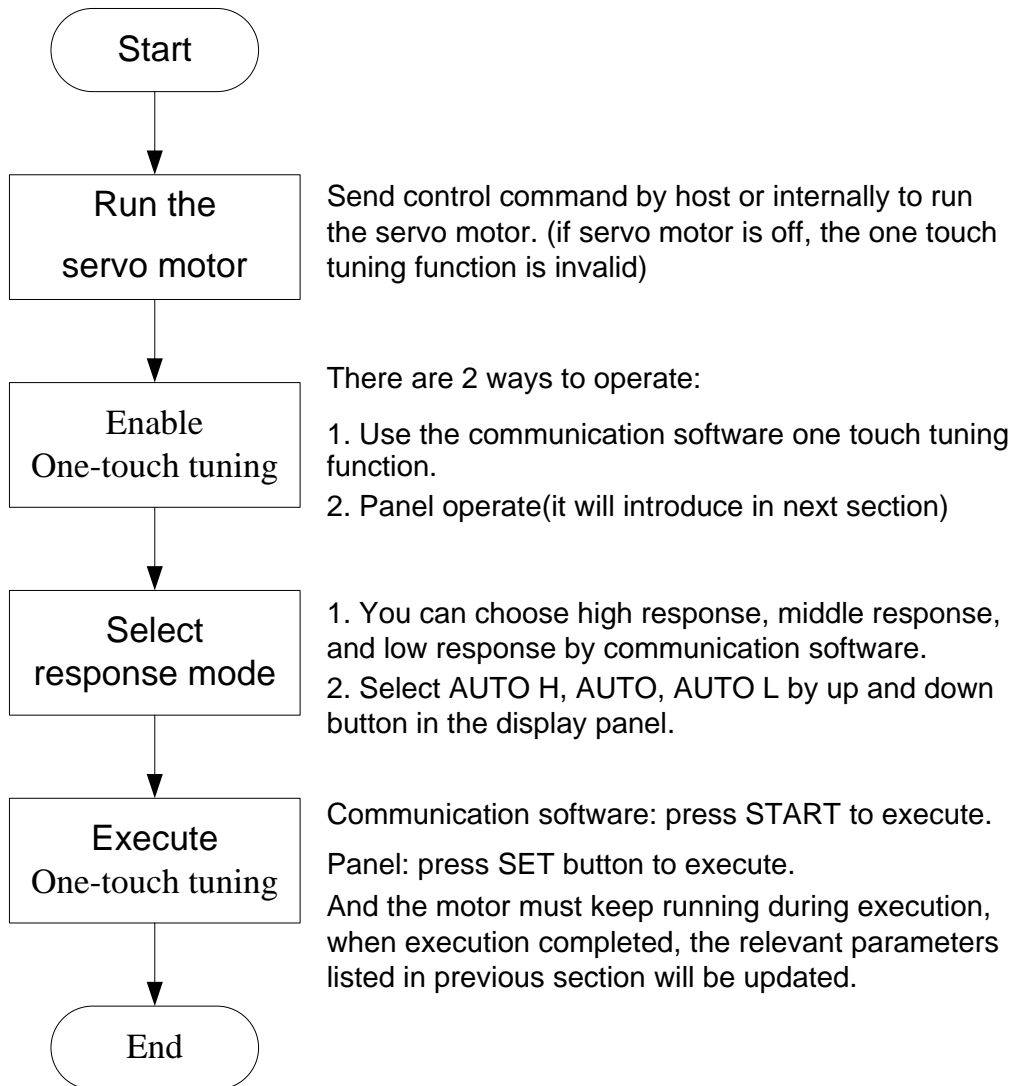

5.3.2.2 one touch tuning display conversion and instructions

(a) Use communication software

(i) Three response modes can be selected in the one touch tuning window of the communication software.

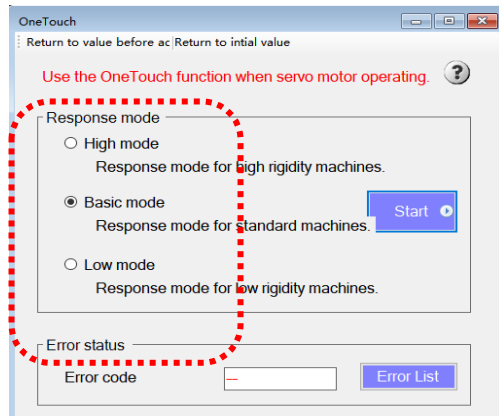

you can refer to below table for selecting response mode.

Response mode	Description
High response	For high stiffness systems
Middle response	For general stiffness systems.
Low response	For low stiffness systems.

(ii) Operate one touch tuning

Select response mode and press START to activate.

i. One touch tuning operation

Select response mode and press START to activate.

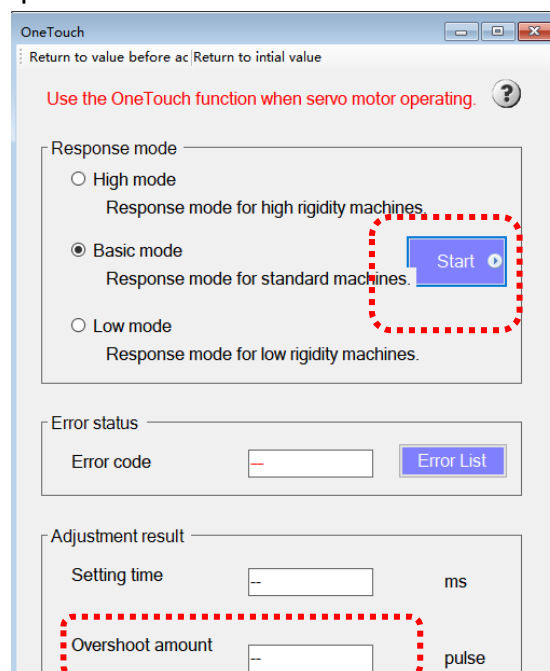

li. If an error occurs, the error code will display on the error status window. The execution progress will be displayed on the status window, and 100% means fully completed.

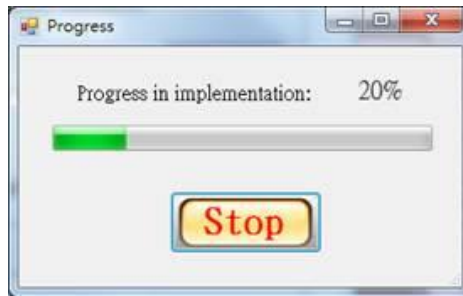

(iii) Clear and reset

It has two methods to clear and reset the tuning related parameters.

- I. Clear: the gain parameters reset to factory default setting.
- II. Reset: the gain parameters reset to the setting value before one touch tuning operation.

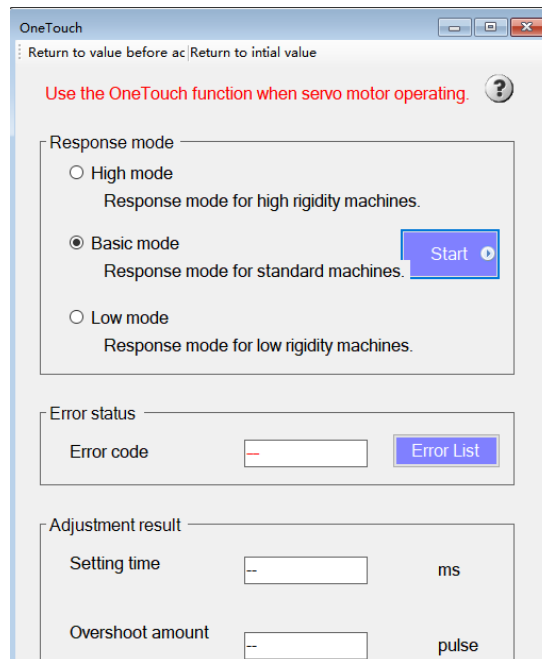

(b) Operate by using panel

(i) It has 2 methods to perform one touch tuning operation on the panel.

(i-1) Press MODE button to enter one touch tuning display (show AUTO), and hold SET button for 2 seconds, the LED will blink as below shows:

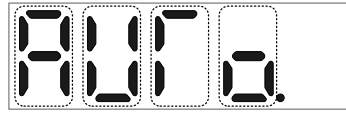

(i-2) In any screen, hold MODE and UP button at the same time for over 3 seconds will enter AUTO screen and LED will blink.



(ii) Press UP or DOWN button to choose one touch tuning response mode.

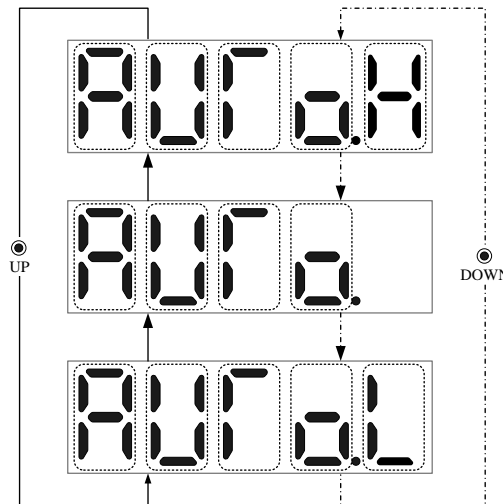

(iii) After selecting the response mode, press SET button to activate the one-touch tuning function and the execution progress will display on the screen.

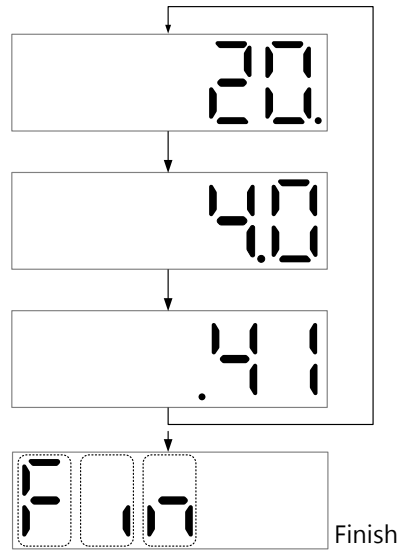

(iv) If you want to terminate the tuning during the adjustment, press the SET button to stop, the panel display and elimination process are as follows:

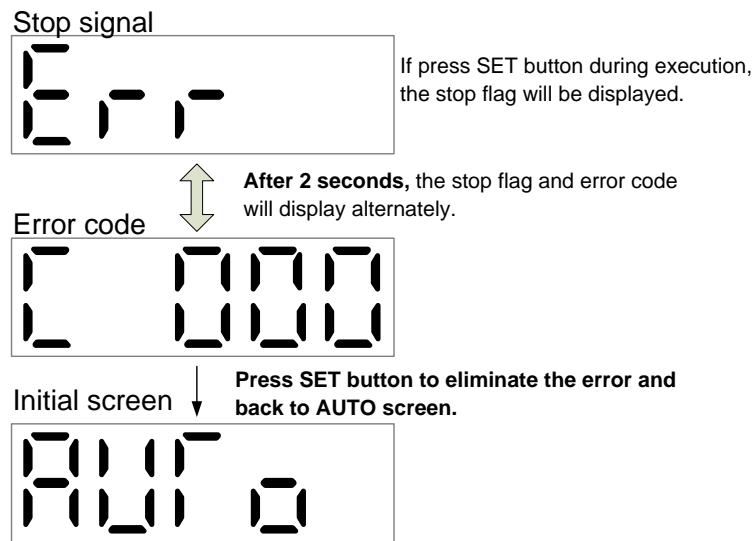

(v) If an error occurs during the adjustment process, the panel display and troubleshooting methods are as follows:

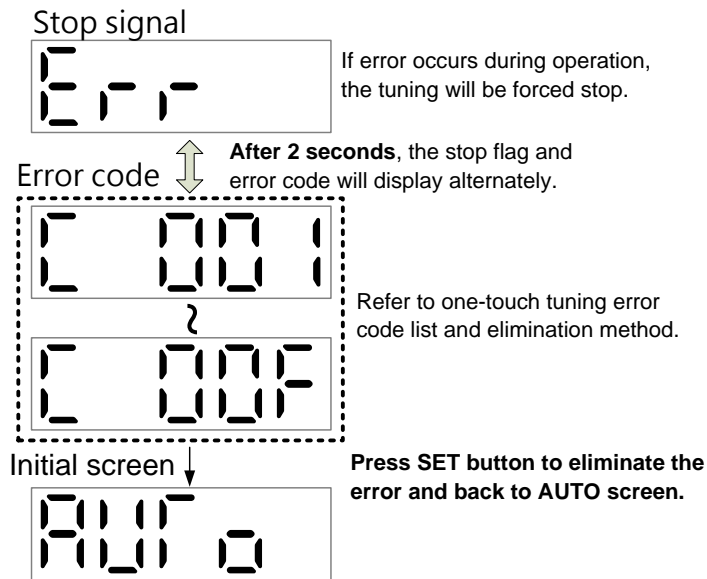

(vi) There are 2 options to clear and reset one-touch tuning related parameters.

- I. Reset to default value (clear mode).
- II. Reset to the value before adjust (back mode).

Press MODE key to enter One-touch tuning (show AUTO) and then press UP or DOWN button to clear or reset parameters, hold SET button for 2 seconds, the servo will activate the function and blink for 3 seconds.

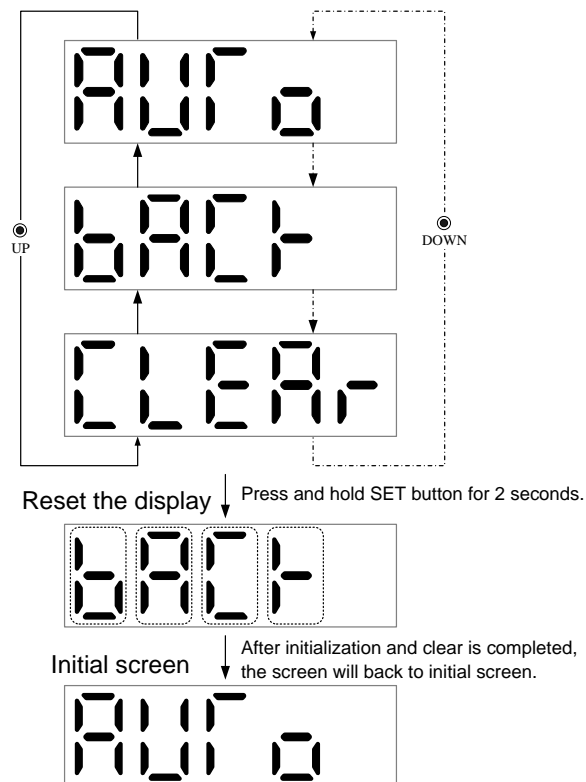

5.3.2.3 One touch tuning error code list and solutions

Code	Error code	Description	Solution
C000	cancellation during tuning	press “stop” icon or “set” button	
C001	Position overshoot excess	Position overshoot exceeds PA12	Increase PA12 setting value
C002	SOV-OFF	Activated in SON-OFF mode	Activate one touch tuning in SON-ON mode
		Try to turn SON OFF during tuning	Don't turn SON OFF during tuning.
C003	Control mode abnormal	Tuning execution is under torque mode	Switch to position or speed mode
		Switched to other mode during tuning	Do not switch to any mode during tuning
C004	Time out	Command period exceeds 30 seconds	Set the rotation cycle more than 30 seconds.
		Motor speed is too low	More than 100 rpm is recommend
		Tuning interval is too short	Tuning interval more than 500mS
C005	Inertia estimation abnormal	Load to motor inertia estimation failure during tuning	When motor runs at 2000 rpm and 3000 rpm, its accelerate and decelerate time should below 2 seconds and 3 seconds. Motor rotation speed should be more than 250 rpm Load inertia should be less than 100 times of rotation inertia. Big change for load and inertia ratio is not suitable for this tuning mode. The acceleration and deceleration torque should be more than 10% of the rated torque.
		Load inertia estimation or inertia ratio change enormously fail due to resonance	Adjust to semi-auto gain tuning mode, stop load inertia estimation and then start tuning. Select [PA02_ATUM] Set [PB06_GD1] by manually set load inertia ratio.
C00F	One touch function invalid	An improper [PA38_AOP3] setting	Set the proper value of [PA38_AOP3]

5.3.3 Auto tuning function

The auto-tuning function can estimate the load inertia ratio relative to servo motor rotor inertia in real time, and automatically set the best gain (GAIN value) for this environment accordingly. The gain adjustment of the servo drive can be performed easily and quickly by the auto-tuning function.

5.3.3.1 Auto-tuning function

Auto-gain tuning mode 1

This mode is the factory default setting. If the servo is set to this function (PA02=0002), it will estimate the load inertia ratio and set the servo gain value automatically. The only parameter that can be modified by the user are the response setting (PA03).

The parameters and settings related to this mode are as follows:

Parameter NO	Parameter abbreviation	Parameter name	the user can modify or automatically estimate the parameters
PA03	ATUL	Auto-tuning response level setting	user can modify
PB06	GD1	servo motor Load inertia ratio	auto-estimate
PB07	PG1	position loop gain	auto-estimate
PB08	VG1	gain adjustment of speed loop	auto-estimate
PB09	VIC	Speed integral gain	auto-estimate

When the servo is about to set the auto-gain tuning mode 1, it has to meet following conditions:

- When motor reaches 2000 rpm/3000 rpm, its accelerate and decelerate time should below 2 seconds / 3 seconds.
- Motor rotation speed is more than 250 rpm
- Load inertia must less than 100 times of rotation inertia.
- Big change for load and inertia ratio is not suitable for this tuning mode.
- The acceleration and deceleration torque is more than 10% of the rated torque

Auto gain tuning mode 2

When the servo motor cannot obtain correct estimated inertia in auto gain tuning mode 1, you can switch to auto gain tuning mode2. In this mode, you can set the parameter (PA02=0003), and load inertia ratio cannot be estimated automatically, it has to manually input to PB06 by the user with correct load inertia ratio value.

The related parameters setting is as follows:

Parameter number	Parameter abbreviation	Parameter name	the user can modify or automatically estimate the parameters
PA03	ATUL	Auto-tuning response level setting	User can modify
PB06	GD1	Servo motor Load inertia ratio	User can modify
PB07	PG1	Position loop gain	Auto-estimate
PB08	VG1	Gain adjustment of speed loop	Auto-estimate
PB09	VIC	Speed integral gain value	Auto-estimate

To activate auto gain tuning mode, you can refer to the following key points:

- To perform auto gain tuning mode 1, you need accelerate and decelerate the motor first, and the inertia ratio will estimate base on current and speed of the motor, the new load inertia ratio will update to PB06 and write into EEPROM(every 30 minutes).
- If the user knows the inertia ratio of the load to the motor, or when the inertia ratio cannot be accurately estimated (when the inertia ratio changes drastically), you can set PA02 to auto gain tuning mode 2, and write the known inertia ratio into PB06 manually. During the time, gain values keeps searching.
- With the value set by the inertia ratio and response level, the servo drive will adjust the optimal controller gain during acceleration and deceleration. The searched gain results will be written into the EEPROM every 30 minutes after turning on the power. When the servo is on, the current gain value saved in the EEPROM will be used as the initial value of the auto gain tuning mode.

Shihlin Servo has set the auto gain tuning mode 1 as the factory default setting. As long as the motor is accelerated and decelerated, the best controller gain will be automatically set. The user only needs to set the required response level to complete the entire process. The sequence is shown in below.

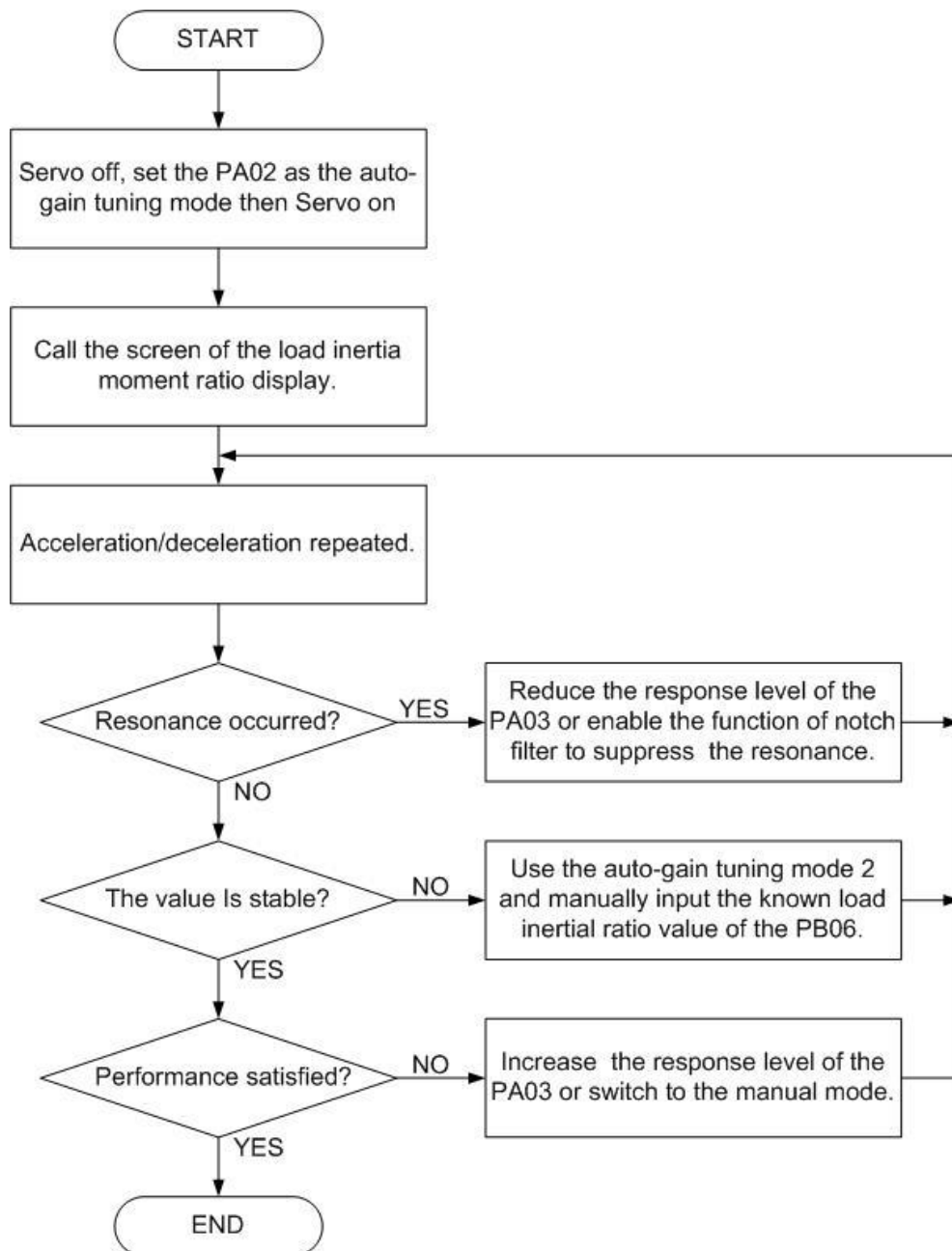

5.3.3.2 The response of auto tuning mode

PA03(response level setting) is for servo overall response level setting, and the response level will impact the whole system bandwidth. The higher response level, the shorter traceability and setting time to command is. But if the response setting is too high, the system will vibrate. It's recommended to set within the range which will not cause vibrate.

If the machine has resonated under the expected bandwidth, and yet the user wants to keep runs the servo in this bandwidth, The machine resonance suppression filter (PB01, PB02,

PB21, PB22) and suppress resonance suppression low-pass filter (PB03) can be used to suppress resonance, and sometimes response level can set a higher level in this condition.

You can refer to section 6. 3. 6 for more information about machine resonance suppression filter and Resonance suppression low-pass filter.

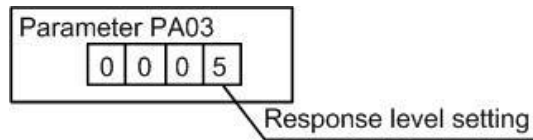

Response level	machine rigidity	Speed response frequency (Hz)	Response level	machine rigidity	Speed response frequency (Hz)
1	Low response	10.0	17	Middle response	67.1
2		11.3	18		75.6
3		12.7	19		85.2
4		14.3	20		95.9
5		16.1	21		108.0
6		18.1	22		121.7
7		20.4	23		137.1
8		23.0	24		154.4
9		25.9	25		173.9
10		29.2	26		195.9
11		32.9	27		220.6
12		37.0	28		248.5
13		41.7	29		279.9
14	47.0	30	315.3		
15	52.9	31	355.1		
16	59.6	32	400.0	High response	

For the response level setting, it is recommended to adjust response level from low response to high response gradually. The possibility of resonance will greatly increase if the default value is too high.

The proper load inertia ratio is a reference data, and its applicable range varies with different systems.

5.3.4 Manually tuning mode

If auto tuning function cannot achieve the requirement, you can use manually tuning mode to adjust gain parameters.

Manually tuning mode

In the position and speed mode, the choice of bandwidth is highly related with the rigidity of the machine and the environment. For machines that require high machining accuracy, it is necessary to set a high-frequency response system, however, increasing the response bandwidth might cause mechanical resonance, and you can use high rigidity machine to avoid.

When the response bandwidth is unknown, you can gradually increase the gain parameter values to increase the response bandwidth. Then, decrease the gain parameter values until machine resonance occurred. The following are the descriptions of the gain adjustment parameters.

name	parameter abbreviation	parameter code	setting range	unit	default value	control mode
Resonance suppression low-pass filter	NLP	PB03	0~10000	0.1ms	17	ALL
Position feed-forward gain	FFC	PB05	0~200	%	0	Pt, Pr
servo motor load inertia ratio	GD1	PB06	0~1200	0.1 times	70	ALL
position loop gain	PG1	PB07	4~1024	rad/s	45	Pt, Pr
Speed loop gain	VG1	PB08	40~9000	rad/s	183	ALL
Speed integral gain	VIC	PB09	1~1000	ms	34	ALL
Speed feed-forward gain	VFG	PB10	0~200	%	0	S, T

Position loop gain (PG1)

This parameter determines the response level of the position loop. Increasing PG1 can improve response frequency, traceability, settling time and position error, but a too high value will make machine vibrate and overshoot. The calculation is as follows:

$$PG1 \text{ setting value} \leq \frac{VG1 \text{ setting value}}{1 + \text{ratio of load inertial to motor shaft}} \times \frac{1}{4}$$

$$PG1 \text{ setting value} \approx \text{speed loop bandwidth} \times \frac{1}{4}$$

Speed loop gain(VG1)

This parameter determines the response level of the speed loop. Increasing VG1 can improve traceability to a speed command, but a too high value will make machine resonance. The Speed loop gain is usually 4~6 times larger than the position loop gain. As the position loop gain is greater than the speed loop gain, machine is likely to resonate or overshoot. The calculation is as follows:

$$\text{Speed loop response frequency(Hz)} = \frac{VG1 \text{ setting value}}{(1 + \text{ratio of load inertial to motor shaft}) \times 2\pi}$$

Speed integral gain (VIC)

This parameter is to clear the fixed deviation of the corresponding command. The smaller the speed integral gain setting, the better the ability to eliminate the fixed deviation. However, when the load inertia is large and there are mechanical vibration elements, the small setting will cause resonance easily. The setting value can refer to the following calculation:

$$VIC \text{ setting value(ms)} \geq \frac{3000 \sim 5000}{VG1 \text{ setting value} / (1 + GD1 \text{ setting value} \times 0.1)}$$

Resonance suppression low-pass filter (NLP)

The greater the load inertia, the lower the system bandwidth. At this time, if you want to maintain a higher bandwidth, you must increase the gain value. However, while increasing the gain, the machine will resonate. you can use the resonance suppression low-pass filter parameter to eliminate the resonance. The larger the setting, the better to improve the high-frequency noise, but too large setting will also cause the instability of the entire system, because the larger the setting, the more serious the phase lag will be. The recommended setting value can refer to the following calculation:

NLP setting value=VGI setting value*10 / 2π * (1+GDI setting value*0.1)

Position feed-forward gain (FFC)

It can reduce the position error and the position setting time, but if the setting is too large, it may cause overshoot under sudden acceleration and deceleration. A too large electronic gear ratio also may cause noise.

Speed feed-forward gain (VFG)

Setting a proper gain value will shorten the tracking time of speed command. Also, a too large setting will cause overshoots during the sudden acceleration/deceleration.

5.3.5 Interpolation mode

This mode is applicable on 2 or more axis servo drives, the controller gain parameter keeps in the automatic tuning function, the main content is as follows:

Interpolation mode 1: only the position gain value (PB07) can be set manually. The remaining gains (PB06, PB08, PB09) are automatically adjusted with PA03 settings.

Interpolation mode 2: The position gain (PB07) and load inertia ratio (PB06) can be adjusted manually, and the other gains (PB08, PB09) are automatically adjusted with the setting of PA03.

5.4 Position mode parameter setting and operation

(1) Turn on the servo drive

After turning on the servo drive, please switch off the DI SON signal, the servo drive display shows servo motor rotation speed 2 seconds later automatically.

(2) Test operation

Use JOG operation to confirm if the servo is running normally.

(3) Parameter setting

After wiring for position control mode, you need to set below parameters to perform basic positioning control function.

Parameter	Name	Setting value	content
PA01(note 1)	Control mode option	□□□0	Position control mode
PA02(note 2)	Auto tuning	0002	Auto gain mode 1
PA03	Auto-tuning response level setting	0012	Middle response
PA06	Electronic gear numerator	1	Set the numerator as "1"
PA07	Electronic gear denominator	1	Set the denominator as "1"
PA13	Command pulse option	Refer to section 8. 3 parameter description	
PD15(note 1)	Digital input filter time option	2	Filter time constant is "4mS"

Note 1: Turn the power off and then turn on to activate the setting parameter.

Note 2: The parameter cannot be set when SON-SG is connected.

(4) Servo ON.

Below is the instruction to perform SERVO ON.

- (a) Turn on the control power supply of servo motor.
- (b) Turn on the servo on signal(SON) (SON-SG is short-circuited).
Servo is ready to run when it's ON, and servo motor switches to SERVO LOCK.
- (c) When motor is stopped, AL.13 occurs if both LSP and LSN are OFF.

(5) Command pulse input

First make servo motor run at low speed and input command pulse after confirming the rotation direction and operation. PP, NP are forward rotation pulse command in open collector type. When line driver signals are applied, please choose PP-PG or NP-NG and use auto-tuning function or manually input controller parameters. To avoid the resonance, you can adjust PA03 to achieve the best speed response.

(6) Homing

It's necessary to check the direction and homing origin before start. Excuse homing if necessary.

(7) Stop

You can follow below steps to stop the motor.

- (a) Servo ON signal (SON) OFF

Disconnect the PWM signal and the servo will switch to a non-blocking free run state.

- (b) Alarm occurs

When alarm occurs, disconnect the PWM signal and activate the dynamic brake to stop the servo motor.

- (c) Emergency stop(EMG) OFF

Disconnect the PWM signal and activate the dynamic brake to stop the servo motor , and the abnormal message will show.

- (d) Turn off the LSP and LSN

LSP/LSN is ON, motor rotates forwardly/reversely. If turn it off, servo motor stops and servo locks.

5.5 Speed mode parameter setting and operation.

(1) Turn on the servo motor

After turning on the servo drive, please switch off the DI SON signal, the servo drive panel will show servo motor rotation speed 2 seconds later automatically.

(2) Test operation

Use JOG operation to confirm if the servo is running normally.

(3) Parameter setting

After wiring for speed control mode, you need to set below parameters to perform basic speed control function.

Parameter	Name	Setting value	Content
PA01(note 1)	Control mode option	□□□2	Speed control mode
PC05	Internal speed command 1	1000	Speed command 1 is 1000 rpm
PC06	Internal speed command 2	1500	Speed command 2 is 1500 rpm
PC07	Internal speed command 3	2000	Speed command 3 is 2000 rpm
PC01	Acceleration time constant	1000	Acceleration time constant is 1000ms
PC02	Deceleration time constant	500	Deceleration time constant is 500ms
PC03	S-curve acceleration/deceleration time constant	0	Disabled
PD15(note 1)	Digital input filter time option	2	Filter time constant is "4ms"

Note 1: Turn the power off and then turn on to activate the parameter setting.

(4) Servo ON

Below is the instruction to perform servo on.

- (a) Switch on the power supply of servo motor.
- (b) Turn SON signal (SON) ON (SON-SG is short-circuited)
Servo is ready to operate when it's ON, servo motor will switch to SERVO LOCK.
- (c) When motor is stopped, AL.13 occurs if both LSP and LSN are OFF.

(5) Start

Choose the speed command by SP1 or SP2 signal, and options are as follows:

(Note) external input signal		Speed command
SP2	SP1	
0	0	N/A(ZERO)
0	1	Inner speed command 1(PC05)
1	0	Inner speed command 2(PC06)
1	1	Inner speed command 3(PC07)

After choosing the speed command, the servo motor starts to rotate when ST1 or ST2 is on. The instruction to choose forward and reverse rotation direction are as follows:

(Note) external input rotation direction		Rotation direction
ST2	ST1	Internal speed command
0	0	Stop(servo locked)
0	1	CCW
1	0	CW
1	1	Stop(servo locked)

NOTE: 0: OFF(STx-SG is open-circuited) 1: ON(STx-SG is short-circuited)

First confirm the rotation direction at low speed, adjust the direction by input signal if needed. In status display panel, you can confirm the motor rotation speed, command pulse number, inertia ratio and so on.

You can also use auto-tuning function or manually input control parameters. To avoid the resonance, you can adjust PA03 to achieve the best speed response.

(6) Stop

You can follow below steps to stop the motor.

(a) Servo ON signal (SON) OFF

Disconnect the PWM signal and the servo switch to a non-blocking free run state.

(b) Alarm occurs

When alarm occurs, disconnect the PWM signal and activate the dynamic brake to stop the servo motor.

(c) Emergency stop(EMG) OFF

Disconnect the PWM signal and activate the dynamic brake to stop the servo motor, and the abnormal message will show.

(d) Turn off the LSP and LSN

When LSP/LSN is ON, motor rotates forwardly/reversely. If turn it off, servo motor will stop and servo will be locked.

(e) Servo motor will decelerate to stop if ST1 and ST2 are both ON or OFF.

5.6 Torque mode parameter setting and operation

(1) Turn on servo drive.

After turning on the servo drive, please switch off the DI SON signal, the servo drive display will show TC(torque command) 2 seconds later automatically.

(2) Test operation

Use JOG operation to confirm if the servo is running normally.

(3) Parameter setting

After wiring for torque control mode, you need to set below parameters to perform basic torque control and speed limit function.

Parameter	Name	Setting value	content
PA01(Note 1)	Control mode option	□□□4	Torque control mode
PC05	Internal speed limit 1	1000	Internal speed limit 1 is 1000 rpm
PC06	Internal speed limit 2	1500	Internal speed limit 2 is 1500 rpm
PC07	Internal speed limit 3	2000	Internal speed limit 3 is 2000 rpm
PC01	Acceleration time constant	1000	Acceleration time constant is 1000ms
PC02	Deceleration time constant	500	Deceleration time constant is 500ms
PC03	S-curve acc. /dec. time constant	0	Disabled
PD15	Digital input filter time option	2	Filter time constant is "4ms"
PA05	Internal torque limit 1	50	Maximum torque 50% as a limit

(4) Servo ON

Below is the instruction to perform servo on.

- (a) Turn on the control power supply of servo motor.
- (b) Turn SON signal (SON) ON (SON-SG is short-circuited)
Servo is ready to operate when it's ON, and servo motor will switch to SERVO LOCK.
- (c) Disable LSP and LSN function.

(5) Start

Use SP1 and SP2 to choose speed limit value. When RS1/RS2 is ON, motor runs forwardly or reversely and generate torque. In order to check the rotation direction, the motor should run at low speed first. please check the input signal if the direction is incorrect.

(6) Stop

You can follow below steps to stop the motor.

- (a) Servo ON signal (SON) OFF
Disconnect the PWM signal and the servo switch to a non-blocking free run state.
- (b) Alarm occurs
When alarm occurs, disconnect the PWM signal and activate the dynamic brake to stop the servo motor.
- (c) Emergency stop (EMG) OFF
Disconnect the PWM signal and activate the dynamic brake to stop the servo motor, and the abnormal message will display.
- (d) Turning on/off RS1 and RS2 simultaneously can enable the motor to free run state.

6. Control function

6.1 Control mode option

Shihlin servo drive has 4 basic control modes, which includes position(terminal input) mode, position(internal register) mode, speed mode, and torque mode. The drive can use single control mode (fixed one mode) and dual mode, the control mode and description are as follows:

Mode		code	PA01 setting	description
Single mode	Position control (terminal input)	Pt	0000	Drive receives the external position pulse command which is input from terminal , then runs the motor to reach the target position.
	Position control (inner register)	Pr	0010	The drive receives the position command which is provided by the internal register (64 groups of registers). and runs the motor to the target position. The DI signal can be used to select the register number.
	Speed control	S	0002	The drive receives the speed command and runs the motor to the target speed. The speed command can be selected by the DI signal(7 groups of register)
	Torque control	T	0004	The drive receives torque command which is provided by three groups of internal torque commands and runs the motor to the target torque.
	Position mode(terminal input)-speed mode	Pt-S	0001	Pt/S is switched mutually via the signal of DI(LOP).

Dual mode	Position mode(terminal input)-torque mode	Pt-T	0005	Pt/T is switched mutually via the signal of DI(LOP).
	Position mode(internal register)-speed mode	Pr-S	0011	Pr/S is switched mutually via the signal of DI(LOP).
	Position mode(internal register)-torque mode	Pr-T	0015	Pr/T is switched mutually via the signal of DI(LOP).
	Speed mode-torque mode	S-T	0003	S/T is switched mutually via the signal of DI(LOP).

✦ After PA01 is been set, you should restart the power to activate it.

6.2 Torque control mode

Torque mode usually used in where torque control is required, such as winding machines, printing machines, injection molding machines, etc. The torque control of SDC servo is from the internal register to control the torque of the servo motor. The basic torque control structure is as follows:

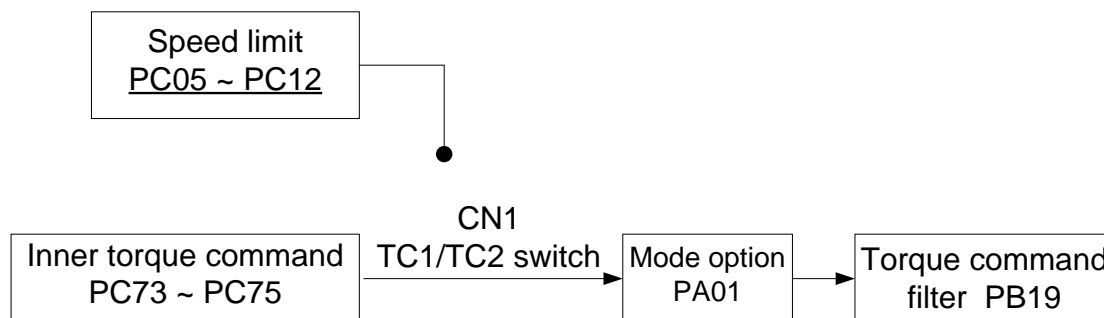

First select torque control mode in mode selection menu, and then you can choose 3 groups of internal register parameters by signals of TC1 and TC2 as torque command.

6.2.1 Torque command

6.2.1.1 Torque command option

Input torque command is 3 groups of torque command set by internal register parameter values.

Torque command code	(Note) Input signal		Torque command	Range	Relate parameter
	TC2	TC1			
TCM	0	0	N/A		
TC1	0	1	Internal torque command 1	-300 ~ 300	PC73

TC2	1	0	Internal torque command 2	-300 ~ 300	PC74
TC3	1	1	Internal torque command 3	-300 ~ 300	PC75

Note 0: OFF(TCx-SG is open-circuited) 1: ON(TCx-SG is short-circuited)

6.2.2 Torque command smoothing

With a proper filter time constant of torque command setting, you can run the servo motor smoothly in response to a sudden change of torque command. The parameter description is as follows.

Name	Parameter code	Setting range	Unit	Default value	Control mode
Torque command filter time constant	PB19	0~5000	ms	0	T

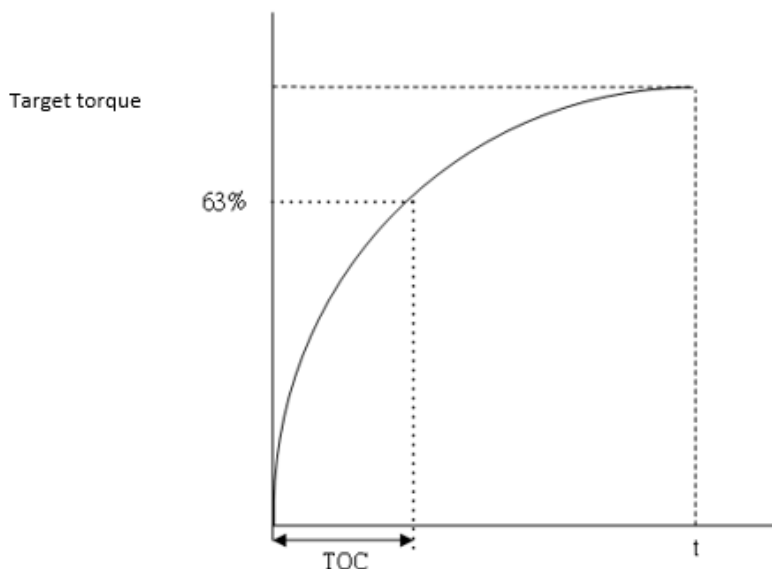

6.2.3 Torque limit of torque control mode

When the torque control mode is performed, there are mainly 2 parameters to control the torque limit function. The description is as follows:

Item	Parameter Abbreviation	Parameter code	Setting range	Unit	Default value	Control mode
Inner torque limit 1	TL1	PA05	0~100	%	100	All
Inner torque limit 1	TL2	PC25	0~100	%	100	All

The TL1 signal function of terminal CN1 is described as follows:

Item	Parameter Abbreviation	Description	Control mode
Inner torque limit option	TL1	When this signal is used, first set PD02 ~ PD09 or PD21~PD24. When the circuit between TL1-SG is short-circuited, it will enable inner torque limit 2 (PC25)	All

Only when setting parameters PD02~PD09 or PD21~PD24 is used as the internal torque limit selection (TL1), the internal torque limit 2 (PC25) can be selected, and there will be two kinds of different results when Switching according to the TL1 of the digital input DI.

(Note) Digital input signal	Effective torque limit value
TL1	
0	The setting value of PA05
1	PC25 > PA05 => PA05 PC25 < PA05 => PC25

Note 0: OFF(TL1-SG is open-circuited) 1: ON (TL1-SG is short-circuited)

6.2.4 The speed limit of torque mode

In torque control mode, the internal SP1,SP2,SP3 can perform speed limit function and there are a total 8 kinds of speed limits for users to adjust manually. The following table lists the speed limit methods.

DI options	Speed limit code	(Note) input signal		Speed limit	Limit range	Related parameter	
		SP2	SP1				
Speed options when SP3 is invalid(default value)		0	0	N/A(ZERO)			
	SC1	0	1	Internal speed limit 1	-6000 ~ 6000	PC05	
	SC2	1	0	Internal speed limit 2	-6000 ~ 6000	PC06	
	SC3	1	1	Internal speed limit3	-6000 ~ 6000	PC07	
SP3 is valid	Speed command code	SP3	SP2	SP1	Speed limit	Range	Related parameter
		0	0	0	N/A(ZERO)		
	SC1	0	0	1	Internal speed limit 1	-6000 ~ 6000	PC05
	SC2	0	1	0	Internal speed limit 2	-6000 ~ 6000	PC06
	SC3	0	1	1	Internal speed limit3	-6000 ~ 6000	PC07
	SC4	1	0	0	Internal speed limit 4	-6000 ~ 6000	PC08
	SC5	1	0	1	Internal speed limit 5	-6000 ~ 6000	PC09
	SC6	1	1	0	Internal speed limit 6	-6000 ~ 6000	PC10
	SC7	1	1	1	Internal speed limit 7	-6000 ~ 6000	PC11

Note 0: OFF(SP_x-SG is short-circuited) 1: ON (SP_x-SG is short-circuited)

- ◆ Before using SC4~SC7 function, make sure to enable the DI SP3 by PD02 ~PD09 setting.

The internal speed limit parameters introduce as follows:

Name	Parameter code	Setting range	Unit	Default value	Control mode
Internal speed limit1	PC05	0 ~ Instant permissible speed	rpm	100	T
Internal speed limit2	PC06			500	
Internal speed limit3	PC07			1000	
Internal speed limit 4	PC08			200	
Internal speed limit 5	PC09			300	
Internal speed limit 6	PC10			500	
Internal speed limit 7	PC11			800	

6.3 Speed control mode

Speed mode is usually used in where precise speed control is required, such as CNC machine, drilling machine, etc. The speed control of SDC servo is performed by the internal register with the following 2 ways:

The first way is to manually set the 7 different required speeds in the 7 command registers (PC05~PC11) before starting the operation, and then use the digital input DI in CN1 to set any three pins to switch as SP1, SP2, SP3.

The second one is to change the value in speed command register by communication.

Shihlin servo also provides S-curve acceleration and deceleration to deal with the problem of non-continuous speed when switching registers, the motor can run smoothly when switching to different speed. In closed-loop system, this device is equipped with PI controller, At the same time, two operation modes (manual and automatic) are also provided for users to choose.

In manual mode, all the parameters can be set, thus all the auto or auxiliary functions are disabled. In auto gain tuning modes, the servo drive performs estimation of the load inertia and sets the related parameters. In this case, the parameter values you set are regarded as the default values. This simple mode provides the user a robust system function for this device, which is different from the adaptability rule that requires a longer learning time in the automatic operation mode. Simple operation mode can suppress external load interference and mechanism resonance in real time, and tolerate change in load inertia.

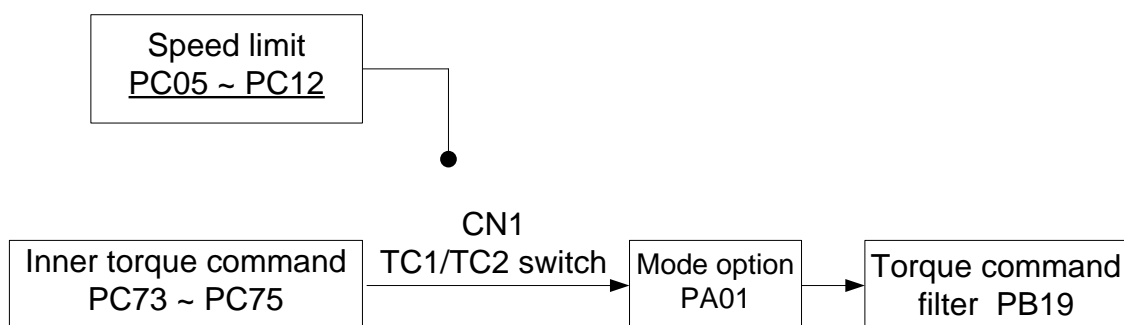

The speed command value is written in the parameters by the user and then switched by the digital input terminal DI. It is recommended that the user use an S-curve smoother and a low-pass filter when operating in the speed mode, which can effectively suppress the irregularity of the motor during operation.

6.3.1 Selection of speed command

The input speed command is 7 types of speed command set by internal parameters.

DI options	Speed limit code	(Note) Input signal		Speed limit	Limit range	Related parameter	
		SP2	SP1				
Speed options when SP3 is invalid(default value)		0	0	N/A(ZERO)			
	SC1	0	1	Internal speed command 1	-6000 ~ 6000	PC05	
	SC2	1	0	Internal speed command 2	-6000 ~ 6000	PC06	
	SC3	1	1	Internal speed command 3	-6000 ~ 6000	PC07	
SP3 is valid	Speed comm and code	SP3	SP2	SP1	Speed limit	Range	Related parameter
		0	0	0	N/A (ZERO)		
	SC1	0	0	1	Internal speed command 1	-6000 ~ 6000	PC05
	SC2	0	1	0	Internal speed command 2	-6000 ~ 6000	PC06
	SC3	0	1	1	Internal speed command 3	-6000 ~ 6000	PC07
	SC4	1	0	0	Internal speed command 4	-6000 ~ 6000	PC08
	SC5	1	0	1	Internal speed command 5	-6000 ~ 6000	PC09
	SC6	1	1	0	Internal speed	-6000 ~ 6000	PC10

					command 6		
	SC7	1	1	1	Internal speed command 7	-6000 ~ 6000	PC11

(Note) 0: OFF(SCx-SG is open-circuited) 1: ON (SCx-SG is short-circuited)

- ◆ Before using SC4~SC7 function, you should enable DI SP3 function by PD02~PD09 or PD21 setting.

6.3.2 Speed command Smoothing

If the motor input command changes rapidly, the motor will have vibration, noise and even overshoot. The user can set the three smooth operation parameters for smoothing process to suppress the negative influence caused by the sudden change of the input command. First of all, the speed acceleration time constant can adjust the slope of the motor when starting to run to the speed set by the user, the speed deceleration time constant can adjust the slope from running to static, and the S-curve acceleration and deceleration time constant can improve the motor stability when starting and stopping.

Item	Parameter abbreviation	Parameter code	Setting range	unit	default value	control mode
Acceleration time constant	STA	PC01	0~20000	ms	200	S, T
Deceleration time constant	STB	PC02	0~20000	ms	200	S, T
S-curve acc. /dec. time constant	STC	PC03	0~10000	ms	0	Pr, S, T

The description of the 3 parameters are as follows:

Speed acceleration time constant

This parameter is the acceleration time when the motor speed changes from 0 rpm to the rated motor speed, which is set as the acceleration time constant. For example, the rated

speed of the servo motor is 3000 rpm, and this parameter is set as 3000 (3s). At this time, the time for the motor to accelerate from 0 rpm to 3000 rpm is 3 seconds. When the speed command is set as 1000 rpm, it takes 1 second for the motor to change from 0 rpm to 1000 rpm.

Speed deceleration time constant

When the motor speed is decelerated from the rated speed to 0 rpm, the required deceleration time is the deceleration time constant. For example, the servo motor runs at 3000 rpm, this parameter is set as 3000(3s), then the time for the motor to decelerate from 3000 rpm to 0rpm is 3 seconds. When the motor is running at 1000 rpm, it takes 1 second to decelerate from 1000 rpm to 0 rpm.

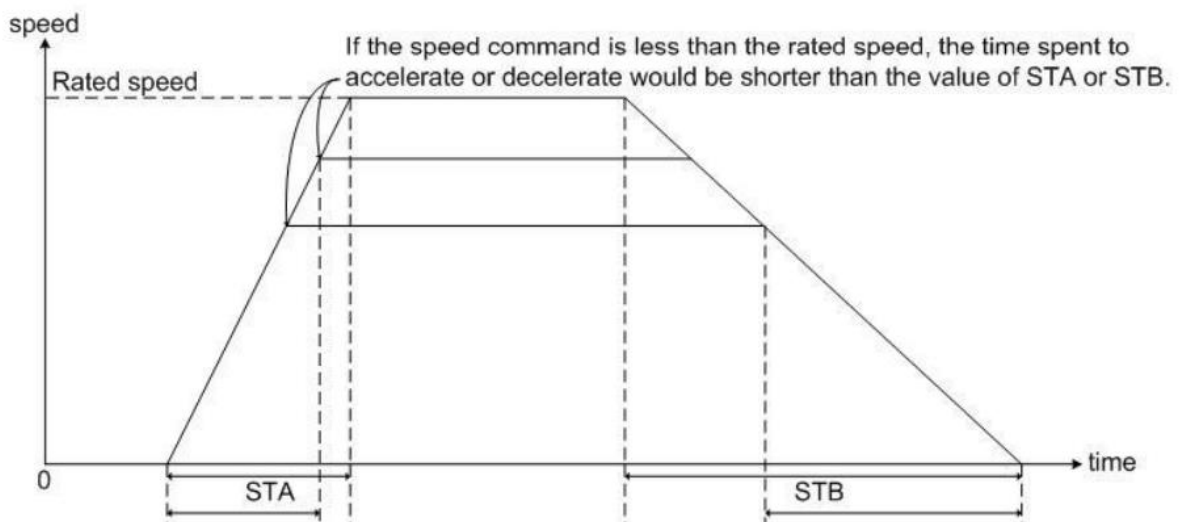

S-curve acc. /dec. time constant

The S-curve acceleration and deceleration method is using three-stage acceleration and deceleration curve to smooth the motor when it starts and stops. Proper setting of STC can improve the stable state of the motor when starting and stopping. The initial S-curve acceleration and deceleration constant is set as 0 seconds. It's recommended to enable this function when using speed mode.

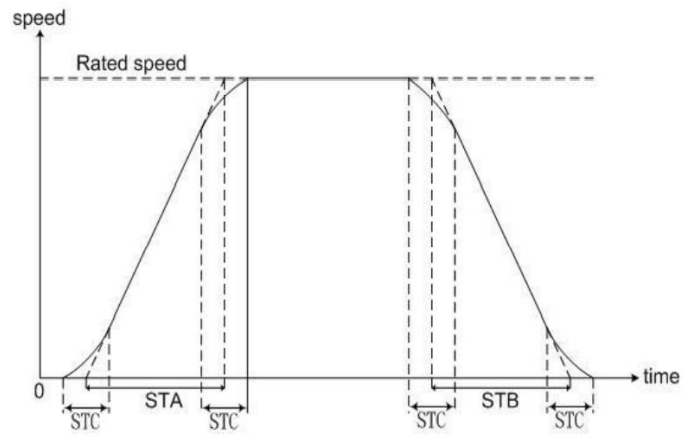

Parameters STA, STB, STC can be set independently. Even if STC is 0, a trapezoidal acceleration and deceleration is still available.

Speed command low-pass filter time constant

Item	Parameter abbreviation	Parameter code	Setting range	Unit	Default value	Control mode
Speed command low-pass filter time constant	SFLT	PB18	0~1000	ms	0	S, T

The larger the value is, the smoother the command curve will be, but the response will also become slower. If it is set as 0, it means that this function is disabled.

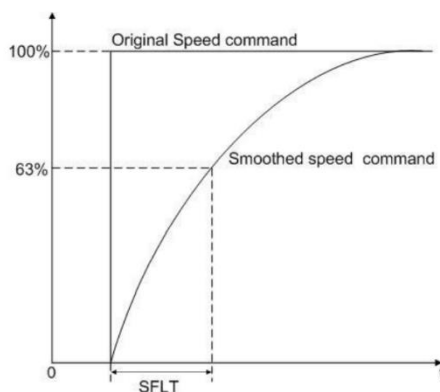

6.3.3 Torque limit of speed control mode

When using the speed mode, the main parameters related to the torque limit function are PA05 and PC25. The table below shows these two parameters.

Item	Parameter abbreviation	Parameter code	Setting range	Unit	Default value	Control mode
Internal torque limit value1	TL1	PA05	0~100	%	100	Pt, Pr, ST
Internal torque limit value 2	TL2	PC25	0~100	%	100	Pt, Pr, S, T

When setting parameters PD02~PD09 is used for the internal torque limit selection (TL1), the internal torque limit 2 (PC25) can be selected, and according to the status of TL1, the following different situations will occur.

TL Signal	The valid value of torque limit
0	PA05 setting
1	PC25 > PA05 => PA05 PC25 < PA05 => PC25

Note 0: OFF(TL-SG is open-circuited) 1: ON (TL-SG is short-circuited)

Item	Signal abbreviation	Description	Control mode
Torque limiting control	TLC	When the torque reaches the internal torque limit, TLC and SG will be conductive, but TLC-SG will be off when the SON signal is off.	Pt, Pr, S

6.3.4 Adjustment of speed loop gain

There are many gains in the speed loop need to be adjusted. The method of adjusting can be set as automatically or manually adjustment by PA02. If it is set to automatic adjustment, the inertia ratio and gain value will be continuously estimated. When it's set to manual mode, the load inertia and gain value of the system must be input correctly by the user, and all its automatic or auxiliary functions will be turned off. The structure diagram of the speed loop is shown in below:

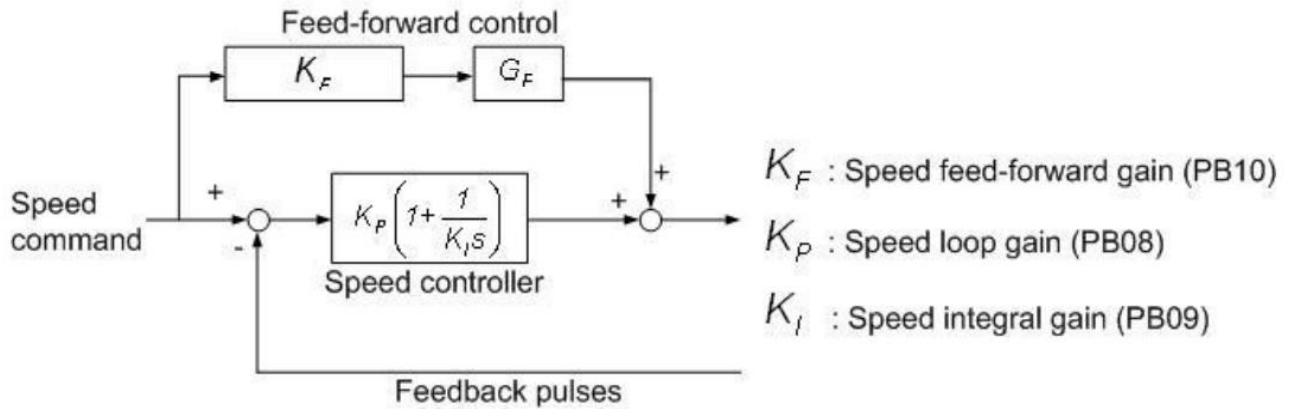

In the speed control loop, some gain adjustment related parameters are summarized as follows:

Item	Parameter abbreviation	Parameter code	Setting range	Unit	Default value	Control mode
Gain tuning mode setting	ATUM	PA02	0000h~0004h	N/A	0002h	Pt, Pr, S, T
Auto-tuning response level setting	ATUL	PA03	1~32	N/A	10	Pt, Pr, S, T
Speed loop gain	VG1	PB08	40~9000	rad/s	183	Pt, Pr, S
Speed integral gain	VIC	PB09	1~1000	ms	34	Pt, Pr, S
Speed feed-forward gain	VFG	PB10	0~200	%	0	S

Auto gain tuning mode

The servo drive will adjust to the optimal controller gain during acceleration and deceleration. And detail introduction can refer to section 5. 3. 2.

Manual mode

When PA02 is set to 0000 or 0001, the main related gain values are speed loop gain (PB08), speed integral gain (PB09), and speed feed-forward gain (PB10). When PA02 is set as 0001, the servo automatically enable the interference compensator function, which can reduce torque ripple, overshoot (overshoot), and speed ripple. It is suitable to use in systems with load changes frequently, but the users should avoid to use in a system with an inertia ratio greater than 10 times. The gain value also needs to be adjusted according to the situation during operation. The diagram as below:

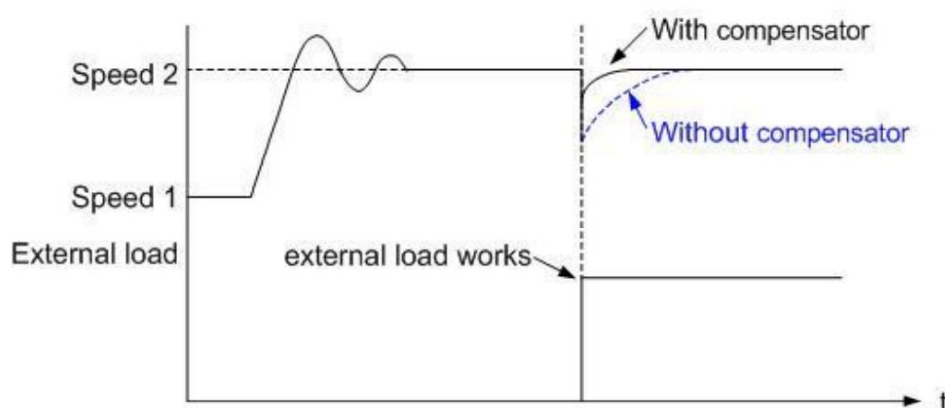

Parameters used in manual mode

Speed loop gain

Increasing the value of this parameter will increase the speed loop bandwidth, but if the setting is too large, it will cause the system vibration. It is recommended to estimate a base value in the automatic mode at first, and then slowly increase the value until the system vibrates.

Speed integral gain

Decreasing the value of this parameter will increase the low-frequency stiffness of the speed loop and reduce the steady-state error. But setting too low may cause the phase lag worse, and may cause system instability.

Speed feed-forward gain

The speed feed-forward gain can reduce the phase lag error and increase the ability of traceability. When the setting value is close to 100, the dynamic tracking error will be very small, and the pre-compensation will be the most completed. If the setting is too low, the improvement effect of the system is not obvious. If the setting value is too large, the system will easily vibrate.

6.3.5 Resonance suppression unit

(1) Automatic high-frequency resonance suppression

Due to the limitation of the mechanism, when the response bandwidth of the control system is too high, it may cause the mechanism to resonate, and this may cause damage on the mechanism. This phenomenon can usually be improved by strengthening the rigidity of the mechanism or reducing the bandwidth of the system, but it may increase the cost and reduce the response. In order to allow users to suppress resonance without increasing the cost and reducing the bandwidth, this servo drive provides the way of Automatic High-frequency Resonance Suppression. its related parameters , setting ranges and default values are shown in the table below. It mainly provides five sets of resonance suppression filters and one set of low-pass filters to suppress resonance for the user to operate manually or automatically as below instructions.

Item	Parameter abbreviation	Parameter code	Set range	Unit	Default value	Command mode
Auto resonance suppression mode	ANCF	PB27	0~2	N/A	1	All
Resonance suppression detection level	ANCL	PB28	1~300	%	50	All
Machine resonance suppression filter 1	NHF1	PB01	10~4000	Hz	1000	All
Machine resonance suppression attenuation 1	NHD1	PB02	0~32	dB	0	All
Machine resonance suppression filter 2	NHF2	PB21	10~4000	Hz	1000	All
Machine resonance suppression attenuation 2	NHD2	PB22	0~32	dB	0	All
Machine resonance	NHF3	PB25	10~4000	Hz	1000	All

suppression filter 3						
Machine resonance suppression attenuation 3	NHD3	PB26	0~32	dB	0	All
Machine resonance suppression filter 4	NHF4	PB45	10~4000	Hz	1000	All
Machine resonance suppression attenuation 4	NHD4	PB46	0~32	dB	0	All
Machine resonance suppression filter 5	NHF5	PB47	10~4000	Hz	1000	All
Machine resonance suppression attenuation 5	NHD5	PB48	0~32	dB	0	All
Resonance suppression low-pass filter	NLP	PB03	0~10000	0.1ms	17	All

Manual mode

The driver provides five groups of filters and one group low-pass filters to manually suppress resonance, the first is PB01, PB02; the second is PB21, PB22; the third is PB25, PB26; the fourth is PB45, PB46; the fifth is PB47, PB48; the low-pass filter is PB03, where PB01, PB21, PB25, PB45, PB47 are suppression frequencies, PB02, PB22, PB26, PB46, PB48 are resonance attenuation rates, and PB03 is time constant.

If the resonance frequency is known, the user can set the frequency of the filter and increase the attenuation rate in sequence until there is no resonance phenomenon (Note 2), or slowly increase the low-pass filter time constant (reduce the low-pass filter bandwidth) until no resonance phenomenon, but this method will reduce the response bandwidth of the system.

Auto mode

The driver provides three groups of filters for users to perform automatic resonance suppression, the first is PB01 and PB02; the second is PB21 and PB22, and the fourth is PB45 and PB46. Among them, PB01, PB21 and PB45 are suppression frequencies, and PB02 PB22 and PB46 are resonance attenuation rates.

When resonance occurs, the user can set PB27 to 1 or 2 to enable the automatic suppression function when the resonance frequency is unknown, the driver will automatically detect the resonance frequency and attenuation rate and set the detected results to the first group, the second group and the fourth group of filters (Note 1). and if PB27 is set to 1, it will automatically be change back to 0 after finished automatic detection; if PB27 is set to 2, it will keep detect resonance and suppress it. For other details about PB27, please refer to the table below.

When PB27 is set to 1 or 2, if the resonance still exists, please check whether one of the parameters of PB02, PB22 and PB46 is 32. If yes, the resonance phenomenon cannot be suppressed by the filter, and it is recommended to reduce the system frequency and re-estimate it. If it is less than 32 and greater than 0, it means that the automatic detection mode has detected the resonance frequency, but the resonance may still exists due to insufficient attenuation rate (Note 1), users can increase the attenuation rate by himself (Note 2). If PB02, PB22 and PB46 are 0, it means that the resonance frequency is not detected, which may due to the detection level (PB28) is too high, and it is recommended to lower the level and then set PB27 to 1 or 2 to perform detection again. The complete automatic resonance suppression flow chart as follows:

Note 1. The attenuation rate detected by the drive is the most suitable one, which may not be the best one. It can ensure the stable operation of the system

Note 2. Be careful when manually adjust the attenuation rate, due to if the setting is too large, it may cause the system unstable.

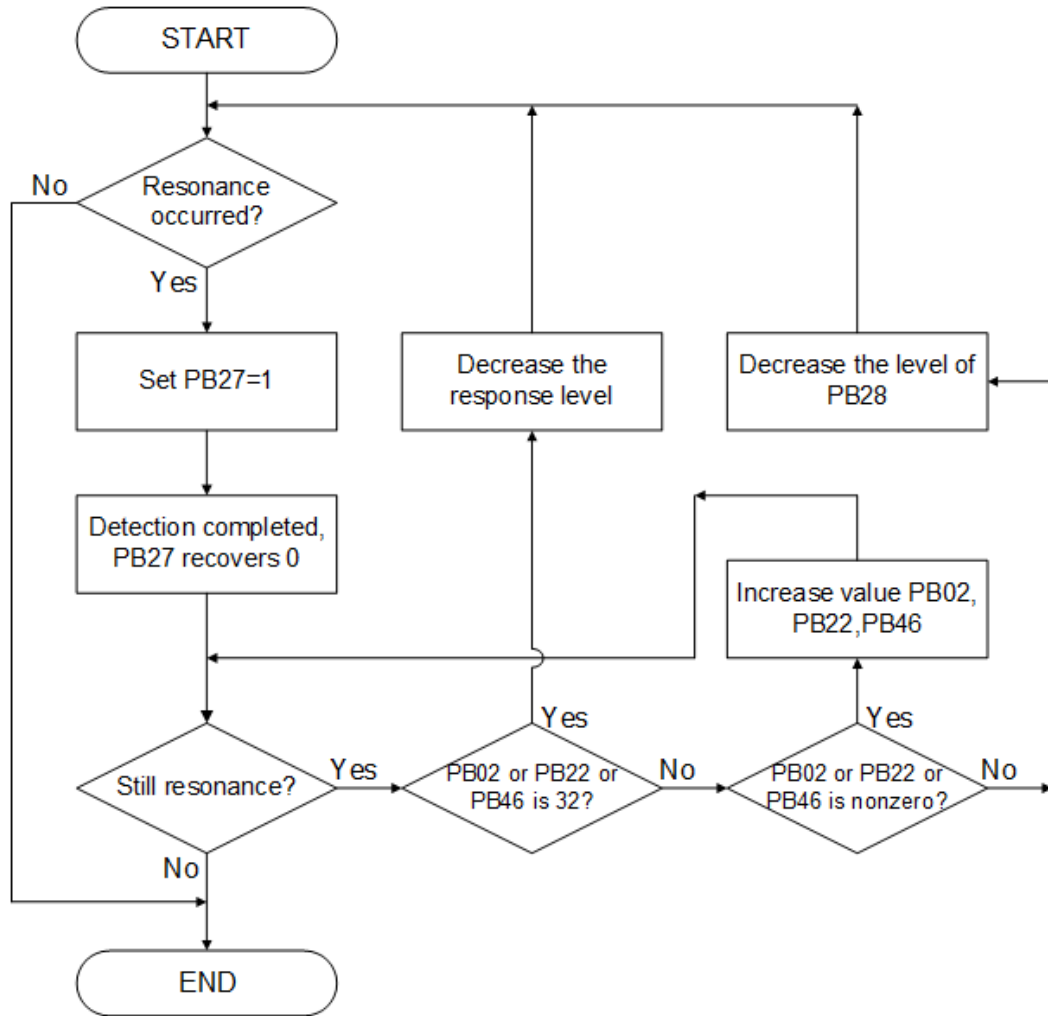

During the auto mode execution, the PB27 value would be changed. The following table explains it.

PB27 transient status	Description
0 → 1	Clear PB01, PB02, PB21, PB22, PB45, PB46 values, enable this auto mode.
0 → 2	Clear PB01, PB02, PB21, PB22, PB45, PB46 values, keep this auto mode running.
1 → 0	Store PB01, PB02, PB21, PB22, PB45, PB46 value, disable this auto mode.
1 → 1	The auto mode is not yet finished.
1 → 2	Hold PB01, PB02, PB21, PB22, PB45, PB46 values, keep this auto mode running.
2 → 0	Store PB01, PB02, PB21, PB22, PB45, PB46 value, disable this auto mode.
2 → 1	Clear PB01, PB02, PB21, PB22, PB45, PB46 values, enable this auto mode.
2 → 2	The auto mode is not yet finished.

(2) Automatic low-frequency vibration suppression

When the command changes instantaneously, the motor and the load will not be synchronized due to insufficient rigidity of the drive system, it will make mechanical vibrate during motor positioning, and causes problems such as inaccurate motor positioning and bad product yield rate. Usually this problem can be improved by reducing the bandwidth of the system, but the response will be worse. In order to suppress vibration without reducing the bandwidth, this servo drive provides an Automatic Low-frequency Vibration Suppression option, its related parameters, setting ranges, and default values are shown in the following table. It mainly provides two groups of low frequency vibration filters for user to operate manually or automatically.

Item	Parameter abbreviate	Parameter code.	Setting range	Unit	Default value	Control mode
Auto vibration suppression mode	AVSM	PB29	0~1	N/A	0	Pt, Pr
Low-frequency vibration detection level	VCL	PB30	1~8000	pulse	50	Pt, Pr
Vibration suppression frequency 1	VSF1	PB31	1~3000	0.1Hz	100	Pt, Pr
Vibration suppression gain 1	VSG1	PB32	0~15	N/A	0	Pt, Pr
Vibration suppression frequency 2	VSF2	PB33	1~3000	0.1Hz	100	Pt, Pr
Vibration suppression gain 2	VSG2	PB34	0~15	N/A	0	Pt, Pr

Manual mode

This servo drive provides two groups of suppression filters for users to manually operate, the first group is PB31, PB32; the second group is PB33, PB34. In which, PB31 and PB33 are suppression frequencies, and PB32 and PB34 are suppression gains. If the vibration

frequency is known, the user can set the vibration frequency to PB31, PB33, and set PB32, PB34 to 1, Set to 1 is to enable the suppression function, and set to 0 is to disable the suppression function. To improve the position response you can increase the gain the value. The higher the value, the better the response (Note 1).

Auto mode

The driver provides two groups of filters for users to automatically suppress low-frequency vibration. The first group is PB31 and PB32; the second group is PB33 and PB34, in which PB21 and PB25 are suppression frequencies, and PB22 and PB26 are resonance attenuation rates. When low-frequency vibration occurs, you can set PB29 to 1 to enable the automatic suppression function when the vibration frequency is unknown. and the driver will automatically detect the vibration frequency and set the detected results to PB31, PB33 and set PB32 and PB34 to 1 to enable the suppression function. And PB29 will be automatically set back to 0 after the automatic detection. The other detailed description of PB29 is as follows.

When PB29 is set to 1, please check whether PB32 and PB34 are both 0 if the vibration still exists. If yes, it means the vibration frequency has not been detected, due to vibration detection level (Note 2) is too high. And the level can be lowered and the detection can be performed again; if it is not 0, it means that the vibration frequency is detected incorrectly because of the vibration detection level may be too low to judge the noise as vibration. You can increase the level and re-detect. the complete automatic suppression flow chart is as follows.

Note 1: Too large gain may cause the motor runs not smoothly.

Note 2:The swing detection level is the peak-to-peak value of vibration,and the unit is pulse.

PB29 flow chart		
PB29 current value	PB28 modified value	Function
0	1	Clear PB31~34, enable auto mode.
1	0	Store current PB31~34, close auto mode.
1	1	Clear PB31~34, enable auto mode.

The vibration suppression flowchart of auto mode.

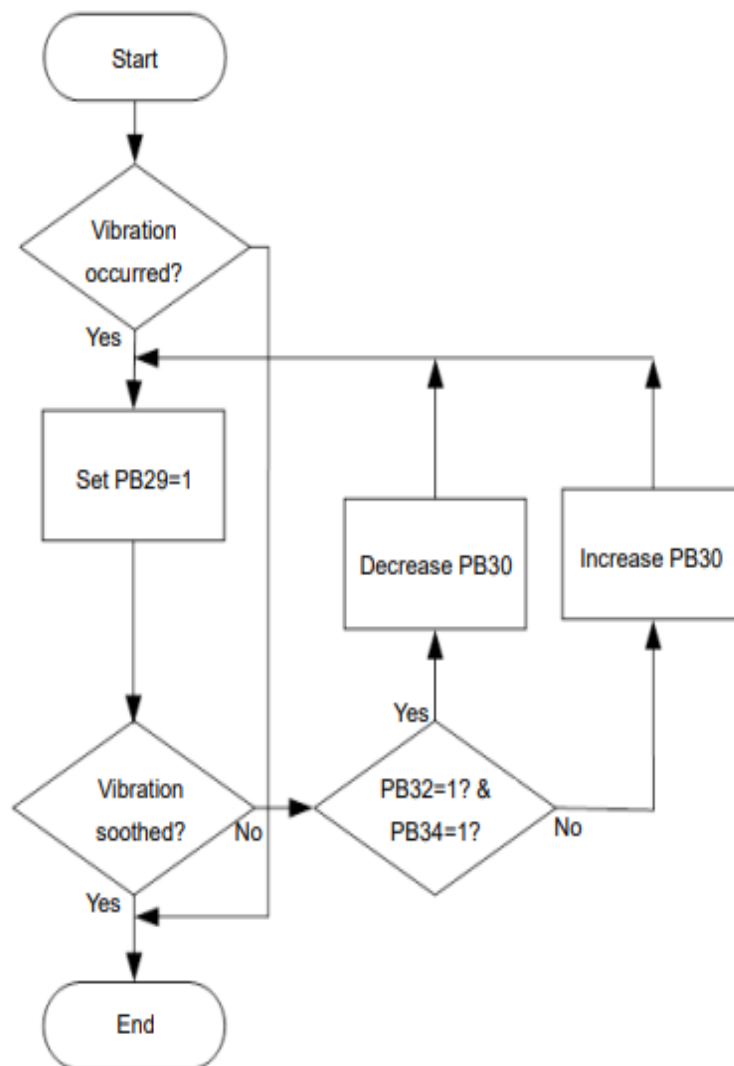

6.3.6 Gain switch function

Shihlin servo drive provides gain switch function when servo motor is running or stop. It can be used through DI pins which are set to make gain switch function valid. If users want to use this function, manual gain tuning mode must be chosen (PA02 is set as 0000 or 0001), otherwise, the gain switch function cannot be used.

It has below applicable occasions:

- (1). servo gain setting is too large and makes big noise, you can use the gain switch function to reduce the system gain.
- (2). When the load inertia ratio changes greatly during operation, to ensure the stability of the servo system, you can use the gain switch function to change the inertia ratio or gain value.
- (3). In order to make the servo system have a higher response or shorten the setting time, you can use the gain switch function to increase the gain

The related parameters and the detail descriptions for gain switch function are listed below:

Item	Parameter abbreviation	Parameter code	Setting range	Unit	Default value	Control mode
Servo motor Load inertia ratio	GD1	PB06	0~1200	0. 1 times	70	Pt,Pr,S
Position loop gain	PG1	PB07	4~1024	rad/s	45	Pt,Pr
Speed loop gain	VG1	PB08	40~9000	rad/s	183	Pt,Pr,S
Speed integral gain	VIC	PB09	1~1000	ms	34	Pt,Pr,S
Gain switch option	CDP	PB11	0000h~0008h	N/A	0000H	Pt,Pr,S
Gain switch condition value	CDS	PB12	0~400000 0	Set according to parameter	10	Pt,Pr,S
Gain switch time constant	CDT	PB13	0~1000	ms	1	Pt,Pr,S
Servo motor Load inertia ratio 2	GD2	PB14	0~1200	0. 1 times	70	Pt,Pr,S
Position loop gain change	PG2	PB15	10~500	%	100	Pt,Pr

ratio						
Speed loop gain change ratio	VG2	PB16	10~500	%	100	Pt,Pr,S
Speed integral gain change ratio	VIC2	PB17	10~500	%	100	Pt,Pr,S

The following will explain the related parameters for gain switching.

- (1). The four parameters , which are servo motor load inertia ratio, position, speed loop gain value, and speed integral gain value GD1, PG1, VG1, VIC (PB06~PB09). They are adjusted in the same way as the manual mode parameters, but its value may be changed during gain switching.
- (2). Gain switch option CDP(PB11)

This parameter is to set the condition of gain switching by changing the lowest digit of the parameter to select the condition. It triggers the gain switch by external digital input(DI) signal, from which you can set PD02~ PD09, PD21~PD24 to enable gain switching.

0	0	0	x
---	---	---	---

- x=0: Disable the gain switching.
- x=1: Activate the gain switching when CDP is ON.
- x=2: Activate the gain switching when position command frequency is equal to or higher than CDS setting.
- x=3: Activate the gain switching when position deviation pulse is equal to or higher than CDS setting.
- x=4: Activate the gain switching when motor speed is equal to or higher than CDS setting.
- x=5: Activate the gain switching when CDP is OFF.
- x=6: Activate the gain switching when position command frequency is less than or equal to CDS setting.
- x=7: Activate the gain switching when position deviation pulse is less than or equal to SDS setting.

x=8: Activate the gain switching when servo motor speed is less than or equal to CDS setting.

(3). Value of gain switching condition CDS(PB12)

The setting value of gain switching condition (kpps, pulse, rpm) changes according to the setting of CDP (PB11). When set to□□□2, the parameter is frequency (kpps), when set to□□□3 , it is pulse number (pulse), when it is set to□□□4, it is rotation speed (rpm). The unit of the setting value will change according to switching item.

PB11 setting	Switch condition	Unit
□□□2	Position command frequency is equal to or higher than CDS setting.	kpps
□□□3	Position deviation pulse is equal to or higher than CDS setting	pulse
□□□4	Motor speed is equal to or higher than CDS setting	rpm
□□□6	Position command frequency is less than or equal to CDS setting.	kpps
□□□7	Position deviation pulse is less than or equal to CDS setting	pulse
□□□8	Motor speed is less than or equal to CDS setting	rpm

(4). Time constant of gain switching CDT(PB13)

The gain switching time constant is to smooth the gain switching. It is used to set the time constant when the CDP and CDS conditions are switched. When the gain is switched, if the gain difference is too large, you can use this parameter to suppress the vibration.

(5). Servo motor Load inertia ratio 2 GD2 (PB14)

This parameter can be set to switch the motor load inertia ratio. If the load inertia ratio does not change during operation, set it to the same value as GD1 (PB06).

(6). The change rate of position gain 2, speed gain 2, and speed integral gain during gain switching.

When performing the gain switching operation, the original servo gain value(%) will be changed to the ratio setting by PG2, VG2, and VIC.

Below are examples to illustrate the gain switching operation.

Example 1: digital input signal use as switching trigger.

①. Relevant parameters setting:

Item	Parameter abbreviation	Parameter code	Default value	Unit
Servo motor Load inertia ratio	GD1	PB06	10	0. 1time
Position loop gain	PG1	PB07	100	rad/s
Speed loop gain	VG1	PB08	500	rad/s
Speed integral gain	VIC	PB09	100	ms
Gain switch option	CDP	PB11	0001	N/A
Gain switch time constant	CDT	PB13	10	ms
Servo motor Load inertia ratio 2	GD2	PB14	20	0. 1time
Position loop gain change ratio	PG2	PB15	80	%
Speed loop gain change ratio	VG2	PB16	120	%
Speed integral gain change ratio	VIC2	PB17	150	%

②. The sequence of gain switch

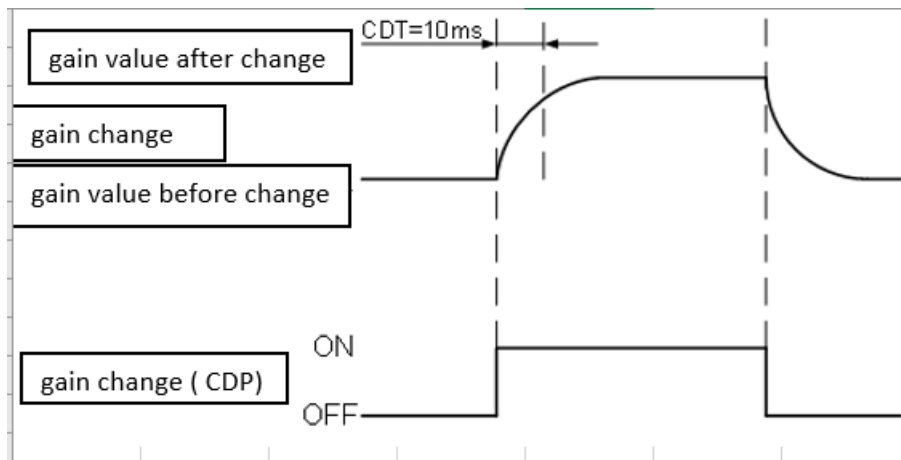

③. The states of parameters change

Item	CDP OFF OFF		CDP ON		CDP OFF
Servo motor Load inertia ratio	10	→	20	→	10
Position loop gain	100	→	80	→	100
Speed loop gain	500	→	600	→	500
Speed integral gain	100	→	150	→	100

Example 2: Position deviation pulse as switch source

①. Relevant parameter setting

Item	Parameter abbreviation	Parameter code	Default value	Unit
Servo motor Load inertia ratio	GD1	PB06	10	0. 1time
Position loop gain	PG1	PB07	100	rad/s
Speed loop gain	VG1	PB08	500	rad/s
Speed integral gain	VIC	PB09	100	ms
Gain switch option	CDP	PB11	0003	N/A
Gain switch condition value	CDS	PB12	100	pulse
Gain switch time constant	CDT	PB13	10	ms
Servo motor Load inertia ratio 2	GD2	PB14	20	0. 1times
Position loop gain change ratio	PG2	PB15	80	%
Speed loop gain change ratio	VG2	PB16	120	%
Speed integral gain change ratio	VIC2	PB17	150	%

②. The sequence of gain switching

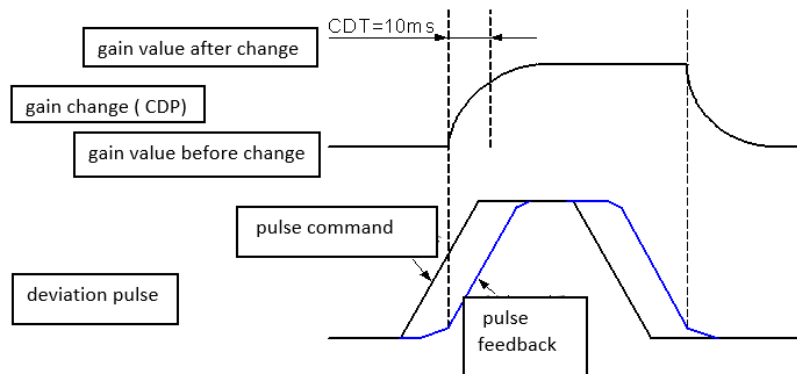

③. The states of parameters change

Item	CDP OFF		CDP ON		CDP OFF
Servo motor Load inertia ratio	10	→	20	→	10
Position loop gain	100	→	80	→	100
Speed loop gain	500	→	600	→	500
Speed integral gain	100	→	150	→	100

6.4 Position control mode

The position control mode is used in where precise positioning is required, such as industrial machinery, processing machines, and so on. There are two ways to input position control mode commands: one is terminal input mode, and the other is internal register input mode. The terminal input mode is to receive the pulse command from the host controller to control the positioning of the servo motor, and the internal register input mode is to manually input 63 groups of position command values (please refer to Chapter 7), and then define the POS1~POS6 to switch the corresponding position command. Below table will introduce the setting of terminal input and internal register input.

Item	Parameter abbreviation	Parameter code	Setting range	Unit	Default value	Control mode	Description				
Control mode setting value	STY	PA01 (*)	0000h ~ 1116h	N/A	0000h	ALL	Control mode setting value: <table border="1" style="margin-left: 20px;"> <tr> <td>u</td> <td>z</td> <td>y</td> <td>x</td> </tr> </table> <u>x: Control mode setting</u> x=0: Position mode <u>y: Position control command select</u> y=0: External input y=1: Internal register input	u	z	y	x
u	z	y	x								

After PA01 is been set, you should restart the power to activate it.

(*)The modification of PA01 would be valid by power off once and power on again.

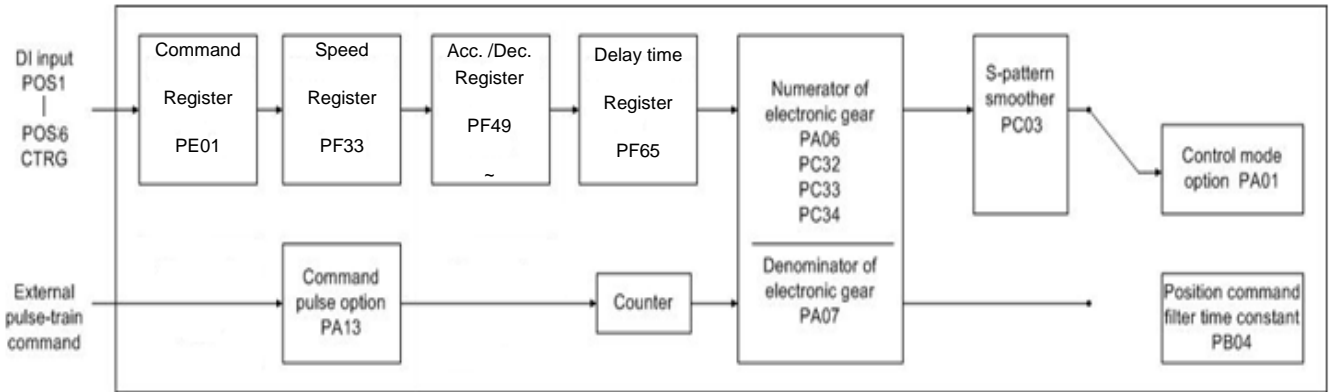

Note: The S-pattern smooth is invalid when the external pulse-train commands are applied.

- ◆ When the external input pulse signal function is activated, the S-curve smoother can not be used.

6.4.1 External pulse command(Pt command)

The pulse command in this mode is provided by an external device. You should set PA01 to 0000 and then restart power. There are three types of input waveform in this mode for users to set by themselves. The pulse trigger type can also be set to positive logic or negative logic. Positive logic means that the servo drive recognizes the pulse valid by the rising edge, on the other hand, negative logic means the falling edge. The related parameters and setting methods are as follows:

Item	Parameter code	Setting range	Unit	Default value	Control mode	Description				
Function mode option 3(command	PA13	0000h ~	N/A	0000h	Pt	Set external input pulse type <table border="1" style="margin-left: auto; margin-right: auto;"> <tr> <td>0</td> <td>z</td> <td>y</td> <td>x</td> </tr> </table>	0	z	y	x
0	z	y	x							

pulse option)		0312h			<p><u>x: input pulse train format select</u></p> <p>x=0:forward/reverse rotation pulse train</p> <p>x=1: pulse train+sign</p> <p>x=2: AB phase pulse train.</p> <p><u>y: input pulse-train logic select</u></p> <p>y=0:positive logic</p> <p>y=1:negative logic</p> <p><u>z: The setting of input pulse filter.</u></p> <p>z=0: the maximum input pulse frequency is 500kpps. (applicable frequency is between 200kpps-500kpps)</p> <p>z=1: the maximum input pulse frequency is 200kpps. (applicable frequency is below 200kpps)</p> <p>z=2: the maximum input pulse frequency is 2Mpps. (applicable frequency is between 500kpps ~2Mpps)</p> <p>z=3: the maximum input pulse frequency is 4Mpps.</p>
---------------	--	-------	--	--	---

						(applicable frequency is between 2MPPS~4MPPS)
--	--	--	--	--	--	---

After this parameter is been set, you should restart the power to activate it.

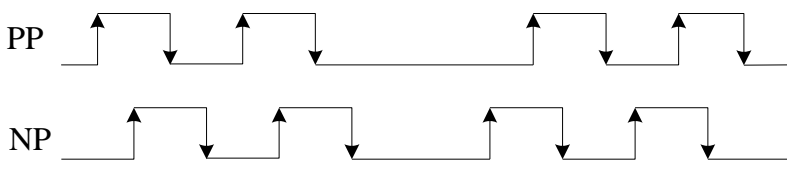
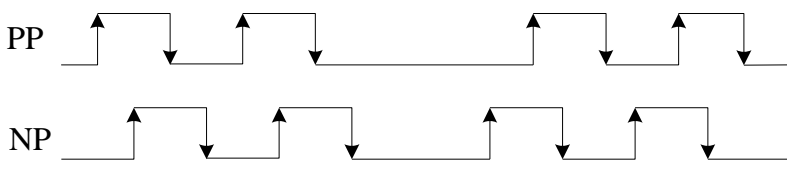
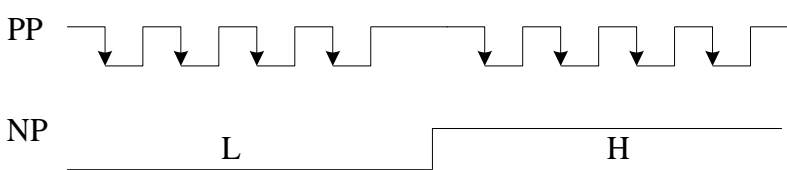
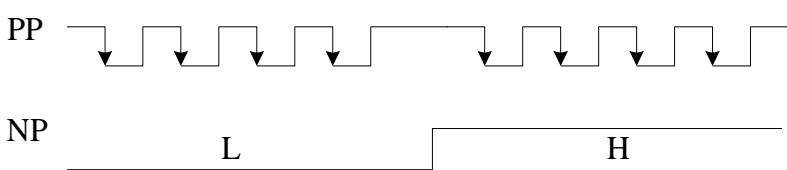
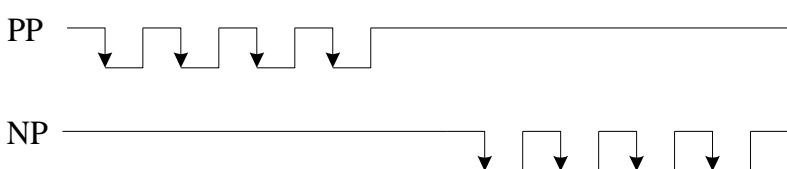
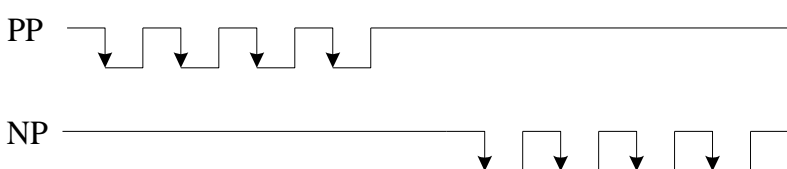
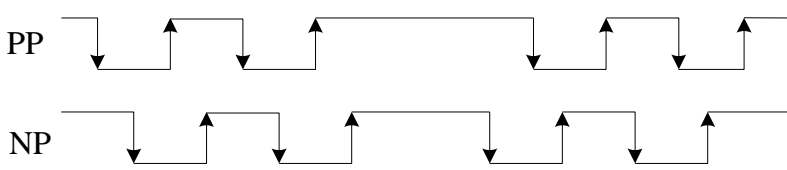
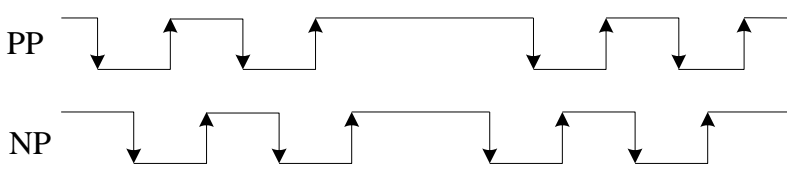
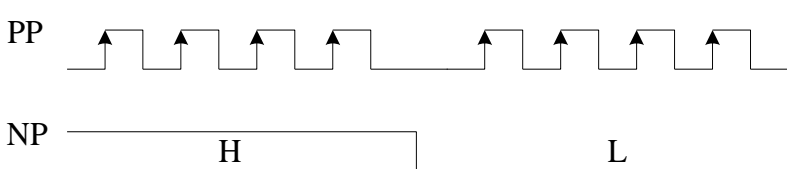
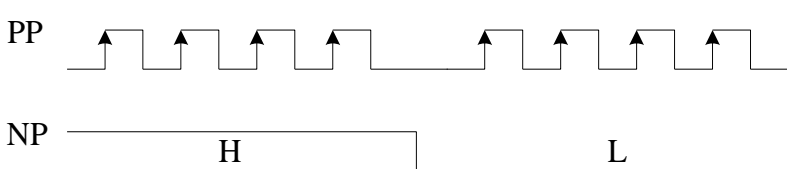
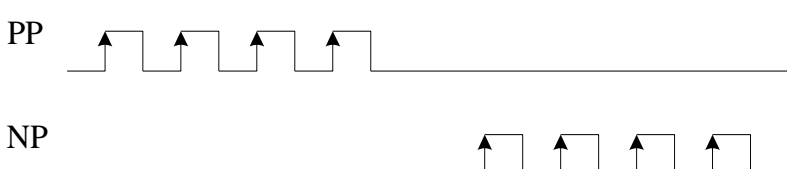
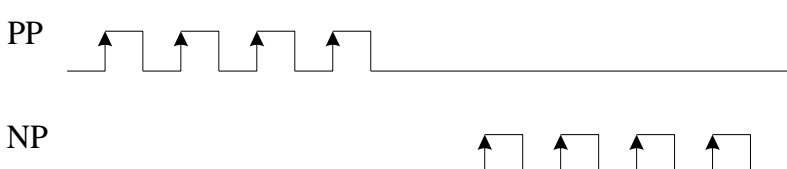
Pulse logic and format		Forward rotation	Reverse rotation
Negative logic	AB phase pulse train	PP 	
	Pulse train + sign	PP 	
	Forward/reverse rotation pulse train	PP 	
Positive logic	AB phase pulse train	PP 	
	Pulse train+ sign	PP 	
	forward/reverse rotation pulse train	PP 	

If pulse input is line drive type, the maximum frequency is 4Mpps. If pulse train is open collector type, the maximum frequency is 200Kpps.

6.4.2 Internal position command (Pr command)

◆ You can refer to detail in chapter 7.

The source of the PR position command is parameters (PE01~PE98), (PF01~PF30) , which is 64 groups of build-in position command registers. By external I/O (CN1, POS1 ~ POS6 and CTRG), one of the 64 groups can be selected as a position command as shown in the following table:

Position command	POS6	POS5	POS4	POS3	POS2	POS1	CTRG	Related parameter
PO	0	0	0	0	0	0	↑	PE01
								PE02
P1	0	0	0	0	0	1	↑	PE03
								PE04
~								~
P50	1	1	0	0	1	0	↑	PF03
								PF04
P51	1	1	0	0	1	1	↑	PF05
								PF06
~								~
P63	1	1	1	1	1	1	↑	PF29
								PF30

POS1~POS6 status: 0(POSx-SG is open-circuited), 1(POSx-SG is short-circuited).

CTRG: the moment of open-circuit to short-circuit.

Absolute and incremental position registers are widely used, which is equivalent to a simple program, users can easily complete periodic operation.

6.4.3 Position command smoothing

It is used to set the filter time constant of the position command. With an appropriate parameter setting, the motor can run smoothly even when it encounters abruptly position command changes.

Item	Parameter code	Setting range	Unit	Default value	Control mode
Position command filter time constant	PB04	0~20000	ms	3	Pt, Pr

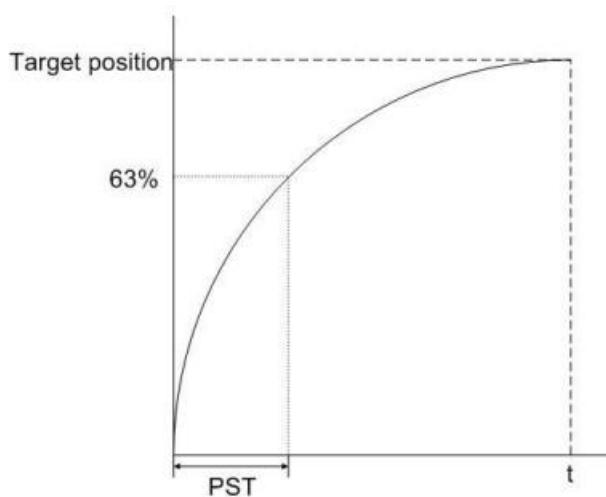

In addition, acceleration and deceleration speed smoothing can be used to make the servo motor run more smoothly. See the table below for the speed smoothing related parameter of position acceleration and deceleration.

Item	Parameter abbreviation	parameter code	Setting range	Unit	Default value	Control mode
S-curve acceleration and deceleration time constant.	STC	PC03	0~10000	ms	0	Pr, S, T

Note: you can refer to chapter 7 for the acceleration and deceleration time in PR.

Acceleration and deceleration speed smoothing can effectively improve the feature of motor acceleration and deceleration. When the motor load inertia increases, or when the inertia changes significantly, the motor will not run smoothly due to the inertia and friction. Users can increase the setting of the STC (PC03) to effectively improve this.

In Pt mode, when position command is determined by external pulse, the parameters STA (PC01), STB (PC02), and STC (PC03) will be invalid, due to the external input pulse command has been determined by the host controller, which is to provide the continuity of speed and angular acceleration.

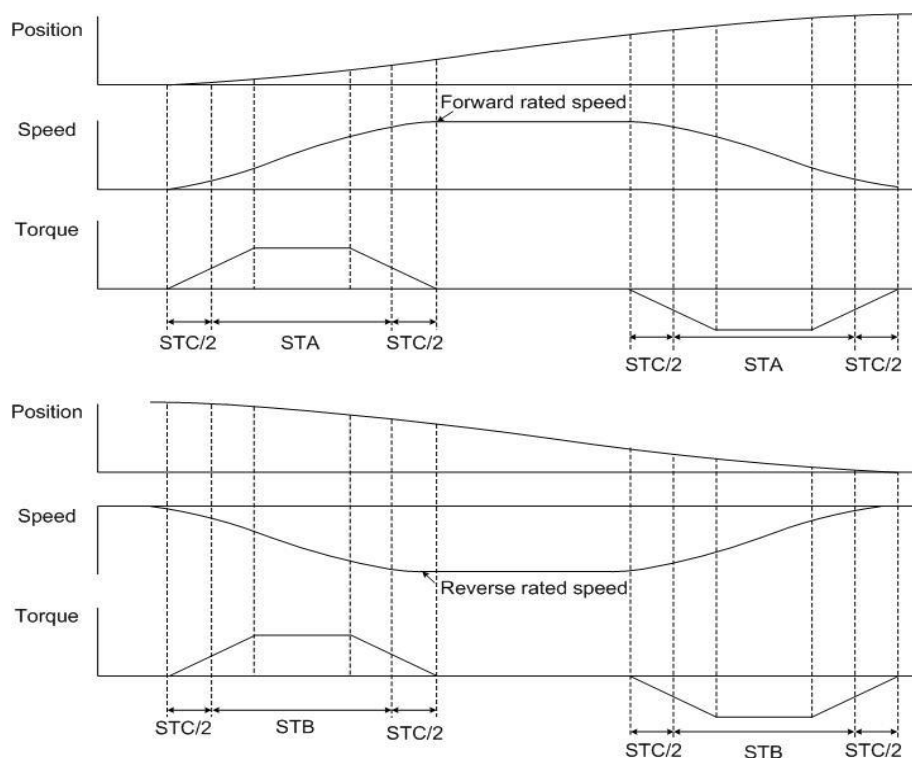

As can be seen in the above figure, for the forward rotation or reverse rotation command from position command, its acceleration and deceleration time is decided by (PF49~PF64).

If the internal register is used for position command, to make the motor run more smoothly, it is recommended that the user set the acceleration and deceleration time (PF49~PF64) and the S-curve acceleration and deceleration time constants (PC03) by themselves.

Note: Please refer to Chapter 7 for above ACC and DEC settings.

6.4.4 Electronic gear

Users could set different electronic gear ratios to enable the mechanism to move different distances. The relevant parameters are presented below:

Item	Parameter abbreviation	Parameter code	Setting range	Unit	Default value	Control mode
Electronic gear numerator	CMX	PA06	1~2 ²⁶	N/A	1	Pt, Pr
Electronic gear denominator	CDV	PA07	1~2 ²⁶	N/A	1	Pt, Pr
Electronic gear numerator 2	CMX2	PC32	1~2 ²⁶	N/A	1	Pt
Electronic gear numerator 3	CMX3	PC33	1~2 ²⁶	N/A	1	Pt
Electronic gear numerator 4	CMX4	PC34	1~2 ²⁶	N/A	1	Pt

When setting the electronic gear ratio, the incorrect setting will cause unexpected fast rotation, so you must set them in SERVO OFF. The electronic gear ratio must be set within the range of $1/50 < (CMX/CDV) < 64000$, otherwise the motor may cannot run normally. The relationship between the electronic gear ratio numerator & denominator and the command can be seen in the figure below.

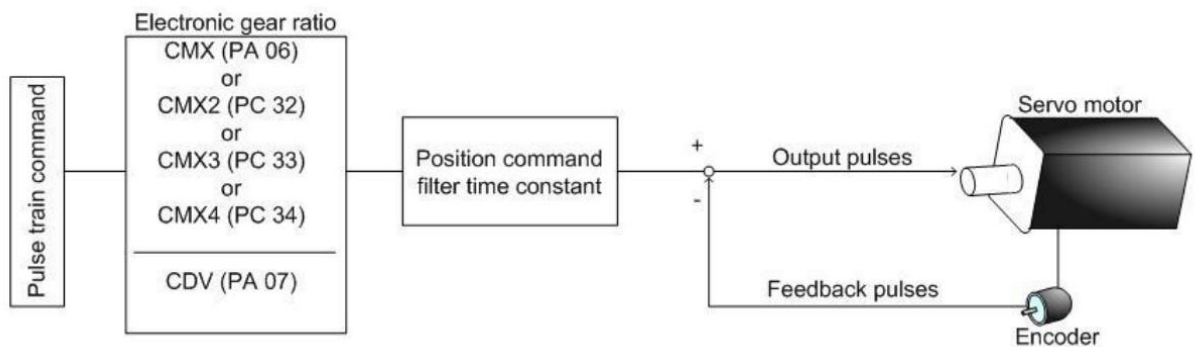

There are four groups of electronic gear ratio numerators for users to switch. You can set the 2 DI input register as CM1 and CM2 to switch. Please refer to the following table for detail.

Item	CM1	CM2	Control mode
Electronic gear numerator 1 (PA06)	0	0	Pt
Electronic gear numerator 2 (PC32)	1	0	Pt
Electronic gear numerator 3 (PC33)	0	1	Pt
Electronic gear numerator 4 (PC34)	1	1	Pt

◆ 0: CMx-SG is open-circuited, 1: CMx-SG is short-circuited.

Calculation of electronic gear ratio

Before calculating the electronic gear ratio, the user must understand the specifications of the system, such as the resolution of the motor encoder is 17bit Pulse/rev, the deceleration ratio of the mechanism, the gear ratio and so on.

The electronic gear ratio calculation is as follows:

E-gear ratio = Resolution of motor encoder / (Load distance per revolution(angle) / Distance pulse to be shifted entered by user)

If there is a deceleration ratio between the motor and the loads, multiply a turn of motor shaft /mechanism turns.

The following is an example to illustrate how to set the electronic gear ratio.

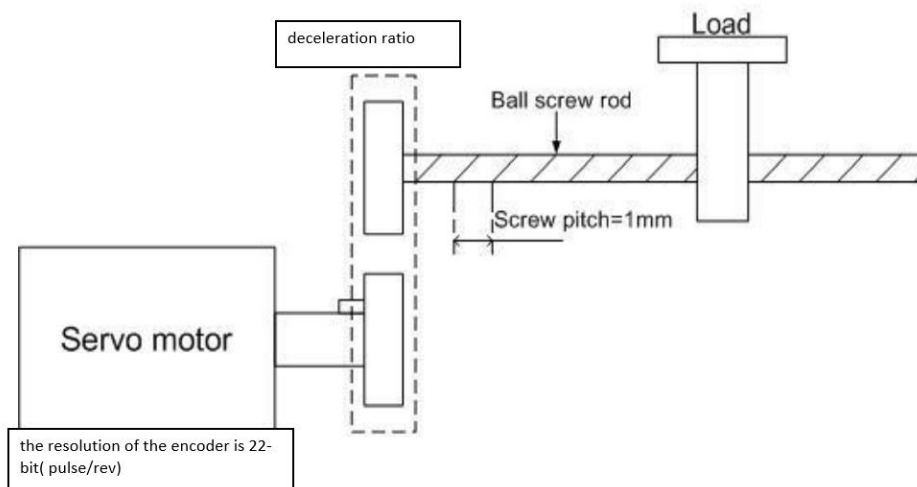

From the figure above, it shows that the load (ball screw rod) has a moving distance of 1mm in one turn, and the motor resolution is 17-bit Pulse/rev. if you want the load axis to rotate 5 μ m, the calculation is as below.

Electronic gear ratio = 131072 / 200

In this way, it can be known that when the numerator of the electronic gear ratio is set to 131072, and the denominator is set to 200. and the ball screw will be shift a 5- μ m distance with a position pulse command.

6.4.5 Torque limit of position loop

Same as section 6. 3. 3.

6.4.6 Position loop gain.

As the position loop contains speed loop, if the user uses the manual mode to adjust the position loop, it's necessary to set the speed gain related parameters first (refer to section 6. 3. 5), and then set the position proportional gain and the position feed forward gain. The position loop gain can be set as a value of 1/4 ~ 1/6 speed loop gain. The user can also use the auto-tuning mode to automatically set the position and speed-related gains. The position loop diagram is shown as below:

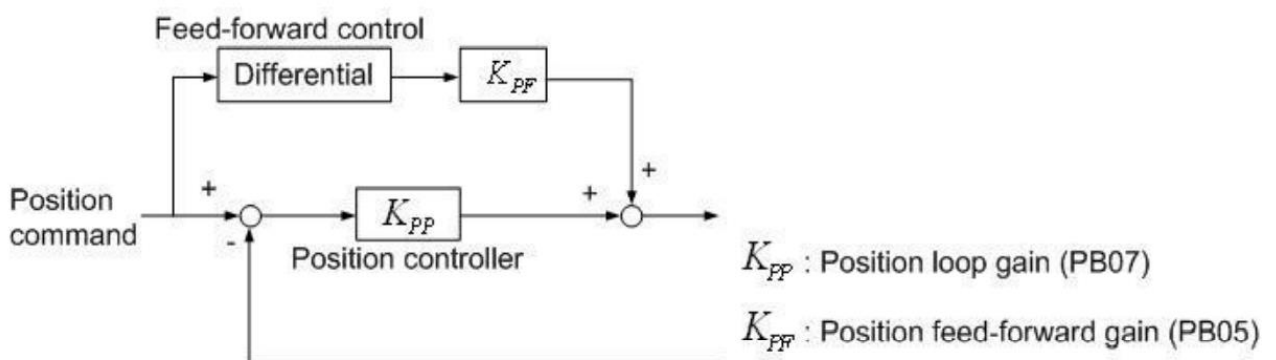

The relevant parameters of position gain adjustment are listed below:

Item	Parameter abbreviation	Parameter code	Setting range	Unit	Default value	Control mode
Auto tuning mode option	ATUM	PA02	0000h~0004h	N/A	0002h	Pt, Pr, S, T
Auto-tuning response level setting	ATUL	PA03	1~32	N/A	10	Pt, Pr, S, T
Position feed-forward gain	FFC	PB05	0~200	%	0	Pt, Pr
Position loop gain	PG1	PB07	4~1024	rad/s	45	Pt, Pr

When the position loop gain PG1 (PB07) is set too large, although the bandwidth and response gets faster, the motor will run back and forth with vibration. This is not allowed in the precise position control application, you must decrease the PG1 value until no vibration.

If the bandwidth is limited by the machine, which makes the position feedback cannot track the position command and cannot meet the reasonable position error requirements, you can use the position feed-forward gain to reduce the dynamic error of the position tracking. In other words, using position feed-forward gain will increase the position setting time relatively.

The position feed-forward gain adjustment method is set from low to high. Theoretically, setting it to 1 should be the best. If the setting is too large, it may cause vibration. The position feed-forward value should be reduced to be used when there is no vibration.

6.5 Dual control mode.

To meet the user's need to switch control modes frequently, Shihlin Servo also provides five dual-mode for users. PA01 can change the dual mode setting, see the table below:

Mode name		Mode code	Parameter PA01 setting	Description
Dual mode	Position with external command - speed	Pt-S	1001h	Pt/S is switched mutually via the signal of DI.
	Position with external command - torque	Pt-T	1005h	Pt/T is switched mutually via the signal of DI.
	Position with inner register command - speed	Pr-S	1011h	Pr/S is switched mutually via the signal of DI.
	Position with inner register command - torque	Pr-T	1015h	Pr/T is switched mutually via the signal of DI.
	Speed - torque	S-T	1003h	S/T is switched mutually via the signal of DI.

When using the dual mode, the assignment of digital input DI and digital output DO is very important. To avoid insufficient DI/DO pin in position mode, you can use external input pulses.

If the digital input DI pin of switching mode is LOP pin assignment, you can set DI as LOP and enable it. The description is as follows:

Item	Parameter code	I/O assignment	CN1 assignment	Description	Control mode												
Control mode switch	LOP	DI	CN1-21(default)	<p>To select control mode when in position/speed control dual mode</p> <table border="1"> <tr> <td>(Note) LOP</td> <td>Control mode</td> </tr> <tr> <td>0</td> <td>position</td> </tr> <tr> <td>1</td> <td>speed</td> </tr> </table> <p>To select control mode when in speed/torque control dual mode.</p> <table border="1"> <tr> <td>(note) LOP</td> <td>Control mode</td> </tr> <tr> <td>0</td> <td>speed</td> </tr> <tr> <td>1</td> <td>torque</td> </tr> </table> <p>to select control mode when</p>	(Note) LOP	Control mode	0	position	1	speed	(note) LOP	Control mode	0	speed	1	torque	Described according to different control mode
(Note) LOP	Control mode																
0	position																
1	speed																
(note) LOP	Control mode																
0	speed																
1	torque																

				in torque/position control Dual mode. <table border="1" style="margin-left: 20px;"> <tr> <td>(note)</td> <td>Control mode</td> </tr> <tr> <td>LOP</td> <td></td> </tr> <tr> <td>0</td> <td>torque</td> </tr> <tr> <td>1</td> <td>position</td> </tr> </table> Note 0:OFF(LOP-SG is open-circuited) 1:ON(LOP-SG is short-circuited)	(note)	Control mode	LOP		0	torque	1	position	
(note)	Control mode												
LOP													
0	torque												
1	position												

- ◆ ST1 and RS2 are defined as the same pin in DI. When in speed and torque dual mode, if LOP is switched to speed mode and this pin will automatically switched to ST1 function, If LOP is switched to torque mode, and this pin will automatically switched to RS2 function.

6.5.1 Position/speed dual mode

There are two position/speed modes: Pt/S and Pr/S. The user can switch between them by the LOP terminal of the digital input DI pin. When PA01 is set to the terminal input or the internal register input in the position mode, the switching sequence diagram of the speed mode is shown as below:

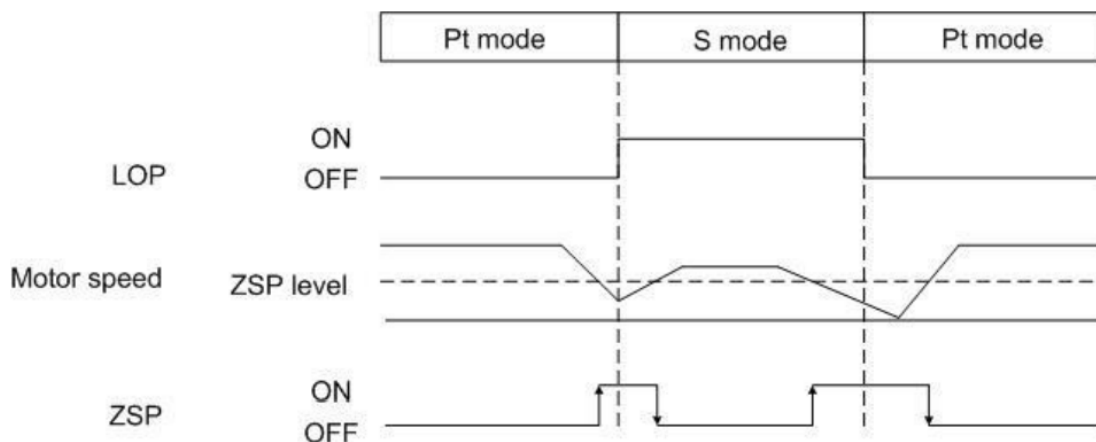

The mode cannot be switched if the motor is running at high speed,. When ZSP is on, the control mode can be switched, and it is recommended that the user wait for the motor stops completely before switching the mode.

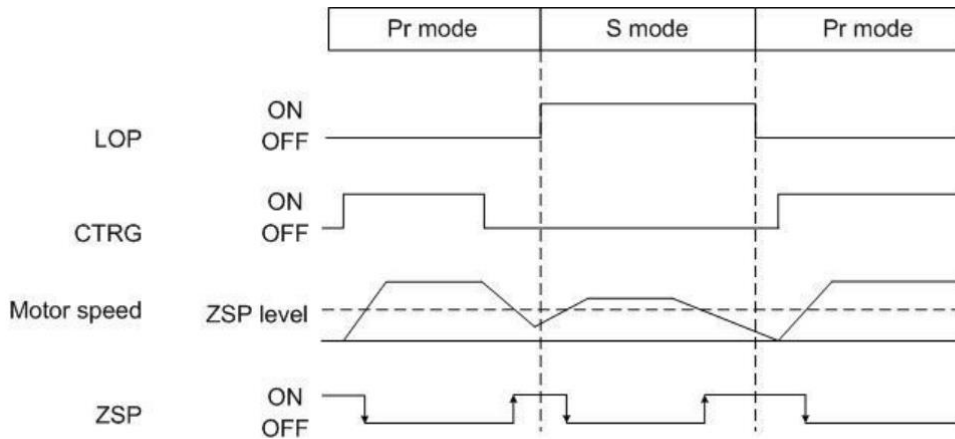

6.5.2 Speed/torque dual mode

Before using the speed/torque dual mode, please set PA01 to 1003H. The user can switch the speed/torque mode through the LOP terminal of the digital input DI pin. Since the DI terminal ST1 (ST2) in speed mode is automatically changed to RS2 (RS1) when switching to the torque mode, the rotation direction of the motor will be reversed when switching between speed/torque mode. The following is the sequence flow of the speed/torque mode:

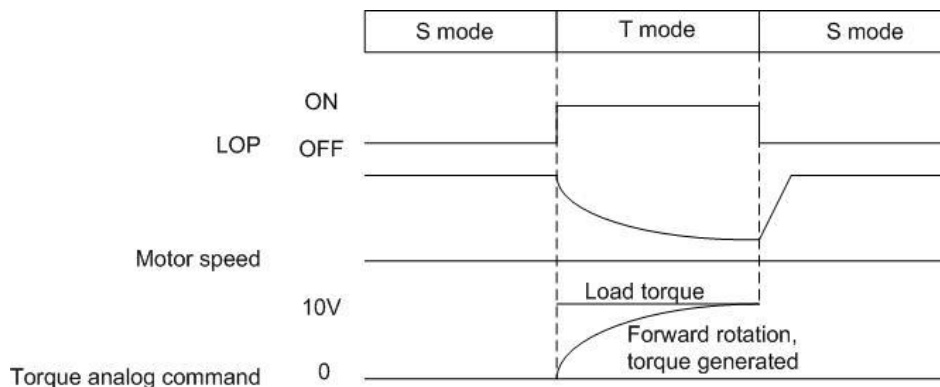

It is recommended to switch speed/torque mode after the motor is completely stopped.

6.5.3 Torque/position dual mode.

There are two torque/position dual modes: T/Pt and T/Pr. The user can set PA01 to 1005 (T/Pt mode) or 1015 (T/Pr mode).

If the motor is running at high speed, the mode cannot be switched. When ZSP is on, the control mode can be switched.

The user can switch the torque/position dual mode through the LOP signal of the DI pin. When switching to the position mode with internal register command, the CTRG signal need to be switched from OFF→ON, you can refer to the following sequence chart for details:

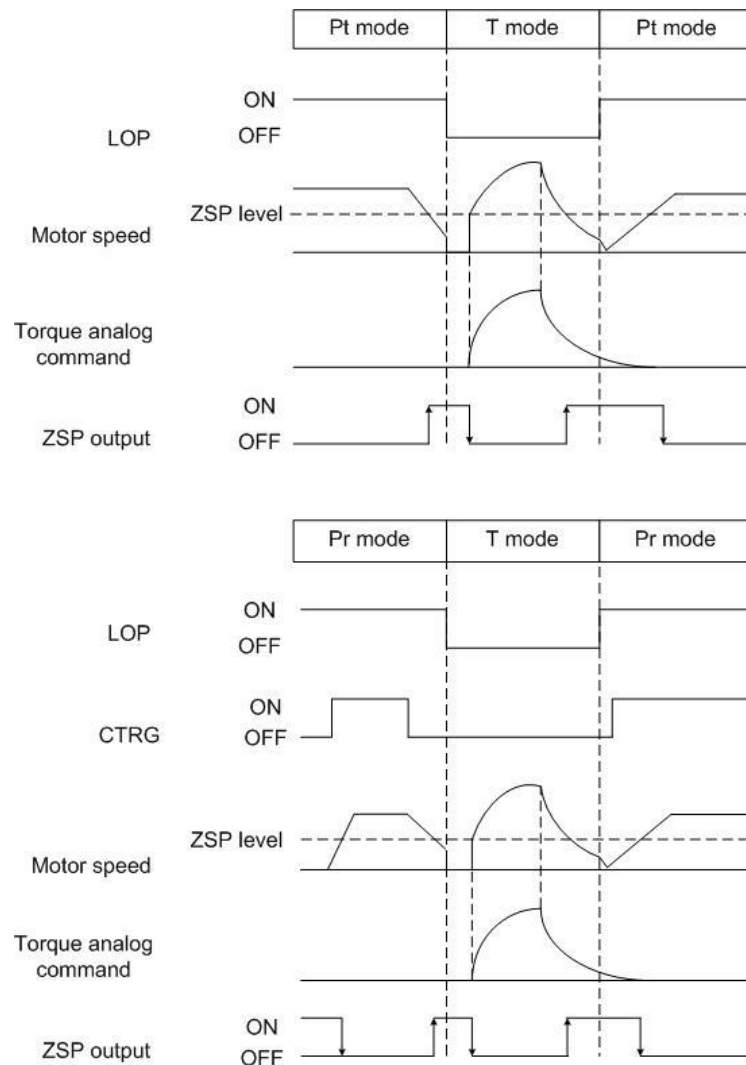

It is recommended that the user wait for the motor to completely stop before performing mode switch.

6.6 Other functions



DANGER

- Before wiring, turn off the power and wait for 20 minutes or more until the charge LED is off, and check the residual voltage by meter. Otherwise, an electric shock may occur.



CAUTION

- Please use designated products for peripheral devices to avoid fire or malfunction.

6.6.1 Selection of regenerative resistor



CAUTION

- It's forbidden to use regenerative resistor and servo drive except for below specified combinations, otherwise, a fire disaster may occur.

If the torque direction of the motor is opposite to the rotation direction, the motor will switch to a power generator, The energy will be transferred from the load to the drive. To avoid the P-N voltage excess, it need regenerative protection function to stabilize the voltage within 370V which is a safe value to avoid IGBT module and capacitor damage. The function is mainly composed of IGBT and resistor. The regenerative energy is consumed by the resistor and its resistance need to be checked when using it. The regenerative protection function is controlled by the regenerative transistor and it should be checked before operation. If the regenerative transistor is damaged, stop the motor urgently to avoid continuous energy regeneration which will damage the drive.

The driver has a built-in regenerative resistor for users. If the regenerative energy is too large, it is recommended not to use the built-in regenerative resistor , use an external regenerative resistor to prevent the built-in regenerative resistor from overheating or failing to consume energy to damage the drive.

For drive above 400W (inclusive), its terminal P-C has a built-in regenerative resistor. If you need to use a larger external regenerative resistor, you can connect the external regenerative resistor to the P-C terminal. (the original one cannot connect to P-C terminal) .

The following table shows the specifications of built-in regenerative resistors provided by Shihlin Servo models:

Drive(W)	Specification of built-in regenerative resistors		The Minimum resistance permissible (Ω)	Consumption power of of built-in resistor (W)
	Resistance(Ω)	Capacitor(W)		
100	N/A			
200	N/A			
400	100	20	100	10
750	40	40	40	20
1000	40	40	40	20

- ◆ Please set the resistance value (PA10) and capacity (PA11) of the regenerative resistor correctly, otherwise it may affect this function.
- ◆ The regenerative capacity processed by the built-in regenerative resistor is the average value of the regenerative capacity , and its value is 50% of its rated capacity; Same rule as the external regenerative resistor.

When the regenerative capacity exceeds the regenerative capacity of the built-in regenerative resistor, an external regenerative resistor should be used. When connecting external regenerative resistor, select regenerative resistors with the same resistance. If you increase the capacitor of the resistor in series or parallel connection, make sure that its resistance meet the requirement. To reduce the temperature, you can use regenerative resistor with thermal switch or by forced cooling. Regarding the load of the resistor, you can consult the manufacturer for detail.

When Choosing the external regenerative resistor, the resistance value is suggested in the above table. To easily estimate the required capacity of the regenerative resistor, below is the instruction for selecting the external regenerative resistor capacity:

(a) Without external load

If the motor is running forwardly or reversely, the regenerated energy from brake will first return to the capacitor of the DC bus, and when the voltage of the capacitor exceeds a certain value, the regenerative resistor will consume excess recharge energy. The selection method of regenerative resistor is as follows; The following table provides the calculation of regenerative energy. Users can refer to and calculate the regenerative resistance they need to choose.

Drive(W)	Motor	Rotor inertia J (x10 ⁻⁴ kg*m ²)	No-load rated speed to static regenerative energy Es(joule)	Ec(joule) capacitor regenerative energy Ec(joule)	maximum motor speed. (rpm)	
low inertia	100	SME-L01030○□□□	0.052	0.26	4.05	3000
	200	SME-L02030○□□□	0.161	0.79	4.05	3000
	400	SME-L04030○□□□	0.27	1.37	8.40	3000
	750	SME-L07530○□□□	1.07	5.28	15.45	3000
	1K	SME-L10030○□□□	1.89	9.33	15.45	3000

The capacity of regenerative resistor is calculated as follows:

$$P_{BR} = 2 \times ((N+1) \times E_S - E_C) / T$$

N: The Load inertia ratio T: Duty cycle(Defined by user)

Assuming that the load inertia is N times the motor inertia, when decelerating from 3000 rpm to 0, the regenerative energy is (N+1)×Es. The regenerative resistance need consume (N+1) × Es-Ec Joules. Assuming that the duty cycle is T sec, then the required regenerative resistor power =2× ((N+1) × Es – Ec) / T. the calculation as follows:

Note: J: motor inertia(unit: **kg*m²**), Wr: maximum speed of operation cycle(unit: rpm)

Step	Item	Calculation and instruction
1	Choose the duty cycle T	User input(repeat operation cycle)
2	Set speed Wr	User input or read from display
3	Set load to motor inertia ratio N	User input or read from display(Dc) (PA01=0002 is valid)
4	Calculate the maximum regenerative energy Es	$E_s = J \times W_r^2 / 182$ (if it's rated speed, you can check in the table)
5	Set the consumable regenerative energy Ec	Refer to the above table
6	Calculate the capacity for regenerative resistor	$2 \times ((N+1) \times E_s - E_c) / T$

Example 1

Taking the low inertia 400W model as an example, the duty cycle T = 1 sec, the maximum speed is 3000 rpm, and the load inertia is 20 times to the motor inertia, then the required power of the regenerative resistor = $2 \times ((20 + 1) \times 1.37 - 8.4) / 1 = 40.74W$. Therefore, an external regenerative resistor above 40.74w is required.

Note: Since the maximum speed of 3000 rpm is with rated speed of 400W, it can be found from the table on the previous page that $E_s = 1.37 J$.

Generally, when the external load inertia is not large, the built-in regenerative resistor is sufficient. When the regenerative resistor is too small, its accumulated energy and temperature will increase. When the temperature exceed a certain value, it may cause the brake resistor to burn out.

You can refer to section 14. 2 when using an external regenerative resistor.

(b) When there is external torque and the motor does the negative work

Usually, the motor does positive work and the motor's torque direction is identical to the rotation direction. However, in some case, if the external load exceed motor torque, external energy returns to the servo drive and generate regenerative energy.

The following figure shows an example, when the motor is at a constant speed, the external load torque is positive in most of the time and a large amount of energy is quickly transferred to the regenerative resistor.

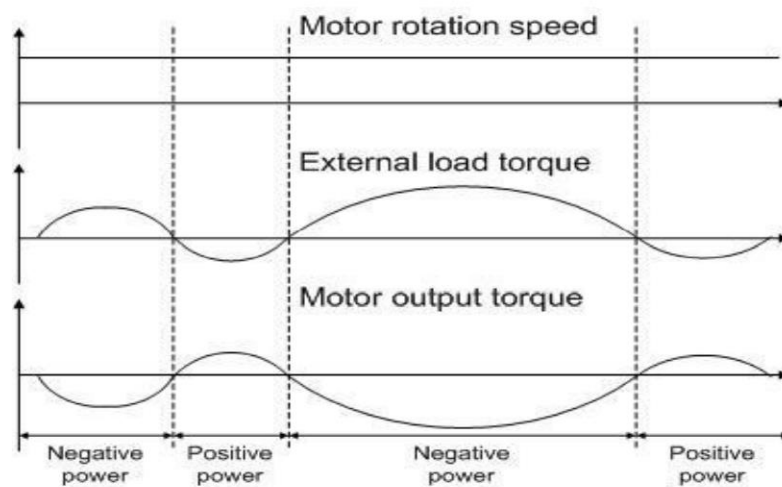

Negative work by external load torque : $T_L \times \omega$

In which T_L : external load torque(Unit Nt-m), ω : rotation speed(Unit rad/s)

Users should try to calculate in the safest situation for safety.

For example: When the external load torque is +50% of the rated torque and the speed reaches 3000 rpm, for the 400W model (rated torque: 1. 27Nt-m), the users need to connect an external brake resistor which power is $2 \times (0. 5 \times 1. 27) \times (3000 \times 2 \times \pi/60) = 399W, 100\Omega$.

Note: $1\text{rpm} = 2\pi / 60$ (rad/s)

6.6.2 Operation of electromagnetic brake

The electromagnetic brake operation is based on: (1)When the MBR is OFF, it means that the electromagnetic brake is disabled and the motor is locked; (2)When the MBR is ON, it means that the electromagnetic brake is operating and the motor can run freely. The electromagnetic brake can be set by PC40 and PC16 to activate. The PC40 controls the delay output time when the electromagnetic brake interlock signal (MBR) is turning on after the initial delay time of SON ON, and PC16 sets delay time from the SON signal OFF to the electromagnetic brake interlock signal (MBR) turn off. Usually electromagnetic brakes are used in the Z-axis (vertical axis) direction to reduce the large amount of heat generated by the continuous resistance of the servo motor and extend the life of the motor. To avoid unnecessary malfunction, the electromagnetic brake must be operated after the servo is turned off. The brake signal controls the solenoid valve to attract magnetism and provides power to turn on the electromagnetic brake.

- ◆ The brake signal controls solenoid valve, makes a loop with external 24V power supply , provides power for electromagnetic brake, and turns on it.
- ◆ Brake coil has no polarity.
- ◆ It is forbidden to use the internal +24V power supply (VDD) of the driver as the motor brake power supply
- ◆ If the MBR DO signal is not applied, you should follow the MBR brake control sequence diagram.
- ◆ To enable DO MBR function, PA01 need to be set to 01 □□.

The operation sequence of electromagnetic brake is as below.

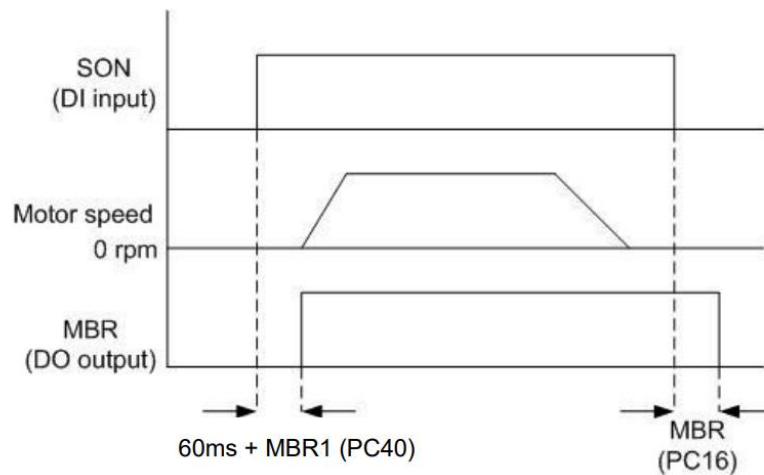

Wiring diagram of electromagnetic brake:

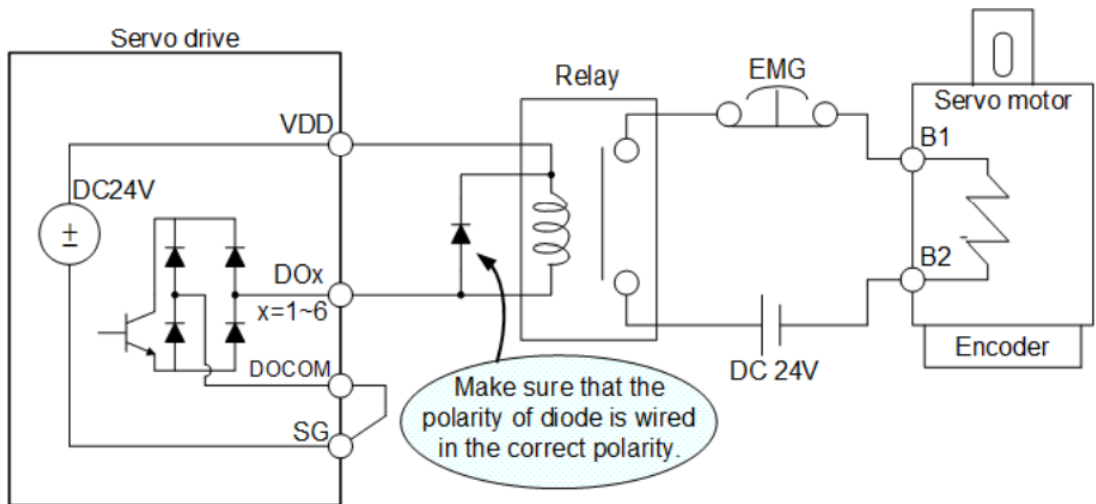

Specification of electromagnetic brake

Motor model name	SME series			
	L01030B	L02030B/ L04030B	L07530B	L10030B
Electromagnetic brake type	Spring brake type			
Rated voltage (V)	DC 24V			
Power consumption (W)	7.2	7.6	8	10
Rated current (A)	0.3	0.32	0.33	0.42
Friction Torque(N · m)	0.3	1.3	2.5	3.2

Caution:

The electromagnetic brake is only used for the safety when the motor is stopped and cannot be used for deceleration.

7. PR (procedure) sequence control introductions

7.1 PR introduction

PR (Procedure) program: In the PR, the PR program is the smallest unit of the command. It contains one or more programs and there are 64 groups of programs can be programmed. They are a group of homing programs (PATH#0) and sixty-three groups of PR programs (PATH#01~PATH#63). There are three different ways to trigger the program.

Standard trigger: Use POS1~POS6 to specify the triggering program, and triggered by CTRG↑.

Event trigger: The program is triggered by the rising or falling edge of EV1~EV4, and refer to the parameters setting of PF83 and PF84.

Software trigger: The program can be triggered by writing the required trigger number into PF82 when servo is started.

7.2 DI/DO and sequences

DI Signal

CTRG, SHOM, STOP, POS1~POS6, ORGP, LSP, LSN, EV1~EV4.

DO Signal

CMDOK, MC_OK, INP(In-position ready), ALM, OVF(Position command overflow), SWPL(Software positive limit reached), SWNL(Software negative limit reached).

The sequence of INP, CMDOK and MC-OK is as below:

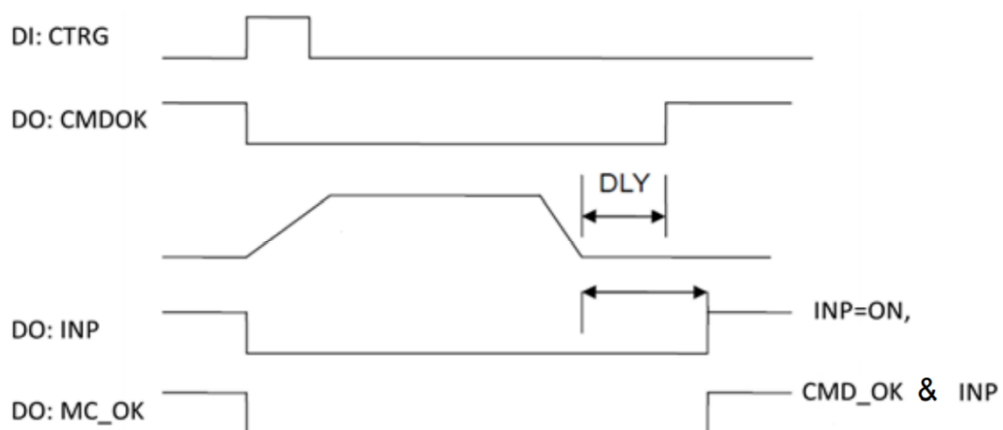

PR command trigger method description

	Command source	Description
STANDARD	DI: CTRG↑+POS1~6	<p>Use DI: use POS1~6 to specify the program number, and triggered by rising edge of CTRG</p> <p>Applicable occasions: PC or PLC issues commands via DI.</p>
DEDICATED	DI: STOP, SHOM	<p>DI: When STOP is activated, the command will be held</p> <p>DI: When SHOM is activated, it will perform homing</p>
EVENT	DI: EV1~EV4	<p>DI: The status change of EV1~EV4 is used as a trigger.</p> <p>Set the program number triggered by OFF→ON with PF83.</p> <p>Set the program number triggered by ON→OFF with PF84.</p> <p>Applicable occasions: sensor, trigger the preset program</p>
SOFTWARE	PF82	<p>In the case of servo start, directly write the program number in PF82 to trigger the program.</p> <p>Panel and PC communication software can be used.</p> <p>Applicable occasions: PC controls the servo drive via communication.</p>

7.3 Parameter setting of PR

Target speed: PF33~PF48, total 16 groups.

	15~0 BIT
PF33~PF48	Target speed: 1 ~ 3000 (<i>rpm</i>)

Acceleration/deceleration time: PF49 ~ PF64, total 16 groups.

	15~0 BIT
PF49~PF64	Acceleration/deceleration time constant: 1 ~ 65500 (ms)

Delay time: PF65 ~ PF80, Total 16 groups

	15~0 BIT
PF49~PF64	Delay time: 1 ~ 32767 (<i>ms</i>)

Relevant parameters of PR

	Parameter description
PA04	Homing mode setting
PA08	Homing high speed option 1
PA09	Homing low speed option 2
PE01	Homing path definition
PE02	Origin offset value definition
PF81	Protection trigger deceleration time
PF82	PR command trigger register(software)
PF86	Software forward limit
PF87	Software reverse limit
PE03~PE98	PATH#01~ PATH#48 parameter settings
PF01~PF30	PATH#49~PATH#63 parameter settings

Definition of PR program path

There are a total of 126 parameters which is PE03~PE98 & PF01~PF30 to set 63 groups of PR programs (PATH#01~PATH#63). PATH#01 can be set by PE03 and PE04, PATH#02 can be set by PE05 and PE06. . . PATH#48 can be set by PE97 and PE98, PF#49 can be set by PF01 and PF02. . . PATH#63 can be set by PF29 and PF30. Therefore, each 63 groups of PR programs have two parameters to set its functions. The following introduce the 63 groups of PR programs, take the parameters PE03 and PE04 of PATH#01 as example, and the settings of the rest of the PR programs follow the same rule.

The first parameter of each PR program is the function setting parameter, the second parameter is the data setting parameter, the definition of the function setting parameter as shown in the following table: (take PATH#01 as an example)

	31~28	27~24	23~20	19~16	15~12	11~8	7~4	3~0 BIT
PE03	-	-	-	-	-	-	-	TYPE
PE04	DATA(32bit)							

In which, the TYPE determines the path form and function, its definition is as follows:

TYPE=1 is constant speed control, TYPE=2 is position control, TYPE=3 is AUTO position control, TYPE=7 is program jump, TYPE=8 is parameter writing, TYPE=A is indexing position control, and TYPE=2 or 3 are both position control, the difference is that TYPE=3 can automatically execute the next program, so there are five different control types including constant speed, positioning, program jump, parameter writing and index positioning.

Constant speed control(TYPE=1): its parameter definition shows in below table(take PATH#01 for example)

	31~28	27~24	23~20	19~16	15~12	11~8	7~4	3~0 BIT
PE03	x	x	DLY	x	DEC	ACC	OPT	1
PE04	DATA(32bit):Target speed(UNIT is determined with the OPT setting.)							

※When this command is executed, the motor starts to accelerate (or decelerate) at current speed (not necessarily as 0) to reach the target speed and keep running.

The definition of OPT option shows as follows:

OPT option			
Bit 7 (0/8)	Bit 6 (0/4)	Bit 5 (0/2)	Bit 4 (0/1)
x	UNIT	AUTO (auto execute)	INS (interrupt)

※ DI:STOP and software limit is acceptable.

INS: If set as INS, it means the current PR will immediately replace the previous PR.

AUTO: When it reaches target speed, the next program will be automatically loaded.

UNIT: Bit 6=0 unit is 0.1 rpm, Bit 6=1 unit is PPS (Pulse Per Second).

ACC/DEC: The value range is 0~F which can be set as the ACC/DEC time number, and its definition is as follows:

ACC/DEC Value	F	E	D	C	B	...	4	3	2	1	0
Relative parameters	PF64	PF65	PF64	PF63	PF62	...	PF53	PF52	PF51	PF50	PF49

DLY:the value range is 0~F which can be set as delay time number, and its definition is as follows:

DLY value	F	E	D	C	B	...	4	3	2	1	0
Relative parameters	PF80	PF79	PF78	PF77	PF76	...	PF69	PF68	PF67	PF66	PF65

Position control : When TYPE=2, finish and then stop. When TYPE=3, the motor would automatically execute the next path after finished.(take PATH#01 for example)

	31~28	27~24	23~20	19~16	15~12	11~8	7~4	3~0 BIT
PE03	x	x	DLY	SPD	DEC	ACC	OPT	2 或 3
PE04	DATA(32bit): Target position: Unit: pulse							

The definition of OPT option is as follow:

OPT option			
Bit 7 (0/8)	Bit 6 (0/4)	Bit 5 (0/2)	Bit 4 (0/1)
CMD (Command type)		OVLP (overlap)	INS (Interrupt)

CMD options		
BIT 7	BIT 6	Description
0	0	Absolute positioning command (position command=DATA)
0	1	Relative positioning command (Position command=current feedback+DATA)
1	0	Incremental positioning command(position command=the end of previous command+ DATA)

※ DI:STOP and software limit is acceptable!

INS: If set as INS, it means the current PR will immediately replace the previous PR.

OVLP: Allow overlap to the next path. Set DLY to 0 when it is used.

CMD: The calculation of the position command ending is shown in the above table.

ACC/DEC: The value range is 0~F which can be set as the acceleration/deceleration time number, and its definition is as follows:

ACC/DEC value	F	E	D	C	B	...	4	3	2	1	0
Relative parameters	PF64	PF65	PF64	PF63	PF62	...	PF53	PF52	PF51	PF50	PF49

SPD: The value range is 0~F which can set as the target speed number, and its definition is as follows:

SPD value	F	E	D	C	B	...	4	3	2	1	0
Relative parameters	PF48	PF47	PF46	PF45	PF44	...	PF37	PF36	PF35	PF34	PF33

DLY:the value range is 0~F which can be set as delay time number, and its definition is as follows:

DLY value	F	E	D	C	B	...	4	3	2	1	0
Relative parameters	PF80	PF79	PF78	PF77	PF76	...	PF69	PF68	PF67	PF66	PF65

Program jump: When TYPE=7, it can jump to the specified PR program number. (Take PATH#01 as an example)

	31~28	27~24	23~20	19~16	15~12	11~8	7~4	3~0 BIT
PE03	x	x	DLY	x	x	x	OPT	7
PE04	PATH_NO: specified PR program number,range(1~63), if set as 0, it stops.							

PATH_NO: Number of target jumping path.

The definition of OPT option is as follows:

OPT option			
Bit 7 (0/8)	Bit 6 (0/4)	Bit 5 (0/2)	Bit 4 (0/1)
x	x	x	INS (Interrupt)

INS: If set as INS, it means the current PR will immediately replace the previous PR.

DLY:the value range is 0~F which can be set as delay time number, and its definition is as follows:

DLY value	F	E	D	C	B	...	4	3	2	1	0
Relative parameters	PF80	PF79	PF78	PF77	PF76	...	PF69	PF68	PF67	PF66	PF65

Parameter writing: when TYPE=8, it enable to write specified parameter(take PATH#01 for example) .

	31~28	27~24	23~20	19~16	15~12	11~8	7~4	3~0 BIT
PE03	x	SOUR	DLY	Target writing parameter			OPT	8
PE04	Source (constant value or parameter number)							

The definition of OPT option is as follows:

OPT option			
Bit 7 (0/8)	Bit 6 (0/4)	Bit 5 (0/2)	Bit 4 (0/1)
x	ROM (Write in ROM)	AUTO (Automatic execution)	INS (Interrupt)

INS: If set to INS, it means the current PR will immediately replace the previous PR.

AUTO: Execute the next PR path when the current PR is completed.

ROM: When BIT6=0, it means the parameter will not saved in EEPROM, when Bit 6=1, it means the parameter will saved in EEPROM in the meantime.

Target writing parameter: the group and number of the writing parameter can be set.

Target parameter		
Bit 16~19	Bit 12~15	Bit 11~8
Parameter group	Parameter number(Decimal)	
A→1	P□05→05	
B→2	P□45→45	
C→3	P□98→98	
D→4	P□77→77	
E→5		
F→6		

(For example: if the writing target parameter is PF34, you can set as 634)

DLY: the value range is 0~F ,it can be set as delay time number, and its definition is as follows:

DLY value	F	E	D	C	B	...	4	3	2	1	0
Relative parameters	PF80	PF79	PF78	PF77	PF76	...	PF69	PF68	PF67	PF66	PF65

SOUR: It is set to choose the data source. The data source setting can choose between Constant and Parameter Value.

SOUR option				Description	
Bit 27	Bit 26 (SOUR)	Bit 25	Bit 24	Data source	Write destination
x	0	x	x	Constant	P□XX
x	1	x	x	P□XX	P□XX

□: Parameter group(A~F) XX: Parameter number

Source: it has different definition according to SOUR setting as shown in the following table.

	Source							
	31~28	27~24	23~20	19~16	15~12	11~8	7~4	3~0 bit
SOUR =0	Constant							
SOUR =1	Rsvd (0x00000)					P_Grp	P_idx	

P_Grp, P_idx: The specified writing parameter group and number

Constant: constant data to be written.

If the written value exceeds the parameter value range, AL.63 will be displayed. If P_Grp is out of range, AL.61 will be displayed. If P_idx is out of range, AL.62 will be displayed. If some parameters cannot be written in when SON is ON, AL.64 will be displayed and the next PR command will stop executing automatically.

Index positioning: When TYPE=A, it can be applied in turret or rotation table.

(Take PATH#01 for example)

	31~28	27~24	23~20	19~16	15~12	11~8	7~4	3~0 BIT
PE03	x	OPT2	DLY	SPD	DEC	ACC	OPT	A
PE04	DATA (0~4194304): index coordinate command, unit pulse							

The definition of OPT is as follows:

OPT option			
Bit 7 (0/8)	Bit 6 (0/4)	Bit 5 (0/2)	Bit 4 (0/1)
00: Always forward (CCW)		OVL P (overlap)	INS (interrupt)
01: Always reverse(CW)			
10: Shortest path. (Judging by current location and target location)			

INS: If set as INS, it means the current PR will immediately replace the previous PR.

OVL P: it allows to overlap the next PR command. Set DLY as 0 when it is used.

ACC/DEC: the value range is 0~F and it can be set as acceleration / deceleration time number, its definition is as follows:

ACC/DEC value	F	E	D	C	B	...	4	3	2	1	0
Relative parameters	PF64	PF65	PF64	PF63	PF62	...	PF53	PF52	PF51	PF50	PF49

SPD: the value range is 0~F and it can be set as target speed number, its definition is as below:

SPD value	F	E	D	C	B	...	4	3	2	1	0
Relative parameters	PF48	PF47	PF46	PF45	PF44	...	PF37	PF36	PF35	PF34	PF33

DLY: the value range is 0~F and it can be set as delay time number, its definition is as follows:

DLY value	F	E	D	C	B	...	4	3	2	1	0
Relative parameters.	PF80	PF79	PF78	PF77	PF76	...	PF69	PF68	PF67	PF66	PF65

The definition of OPT2 option is as follows:

OPT2 option			
Bit 27 (0/8)	Bit 26 (0/4)	Bit 25 (0/2)	Bit 24 (0/1)
x	AUTO	S_LOW	

S_LOW: The speed unit options.

S_LOW =0 means the speed unit 0.1 rpm.

S_LOW =1 means the speed unit 0.01 rpm.

S_LOW =2 means the speed unit 1 rpm.

AUTO:Executes the next PR path when the current PR completes

DATA:Set each indexing positioning coordinate value.

DATA format
Pulse: 0~1048575

Homing definition: set by PE01 and PE02.

	31~28	27~24	23~20	19~16	15~12	11~8	7~4	3~0 BIT
PE01	BOOT	x	DLY	x	DEC1	ACC	PATH	
PE02	ORG_DEF (32 bit)							

PATH: set the action after homing, and its definition is shown in the table below:

PATH option		
Bit 4~7	Bit 0~3	Description
0	0	Stop after homing.
0	1	Execute PATH#01 after homing.
0	2	Execute PATH#02 after homing.
~	~	~
3	E	Execute PATH#62 after homing
3	F	Execute PATH#63 after homing.

ACC: the value range is 0~F and it can be set as acceleration time number, its definition is as follows:

ACC value	F	E	D	C	B	...	4	3	2	1	0
Relative parameters	PF64	PF65	PF64	PF63	PF62	...	PF53	PF52	PF51	PF50	PF49

DEC1: the value range is 0~F, and it can be set as the first deceleration time number, its definition is shown as below:

ACC value	F	E	D	C	B	...	4	3	2	1	0
Relative parameters	PF64	PF65	PF64	PF63	PF62	...	PF53	PF52	PF51	PF50	PF49

The second deceleration time is same as the deceleration time of STP in PF81.

DLY: the value range is 0~F and it can be set as delay time number, its definition is as follows:

DLY value	F	E	D	C	B	...	4	3	2	1	0
Relative parameters	PF80	PF79	PF78	PF77	PF76	...	PF69	PF68	PF67	PF66	PF65

BOOT: To set whether to execute the homing when the servo is started for the first time

BOOT option	
Bit 28~31	Description
0	NOT execute homing when servo starts for the first time
1	Execute homing when servo starts for the first time

ORG_DEF: the coordinate value of the origin and it may not be 0.

ORG_DEF format
Pulse: $(-2^{31}) \sim (2^{31}-1)$

The homing does not have the SDA servo origin stop function to return to the origin! Since the motor must decelerate to stop after the origin is found (origin signal or Z pulse), and the stop position must be a short distance beyond the origin as shown in the figure below:

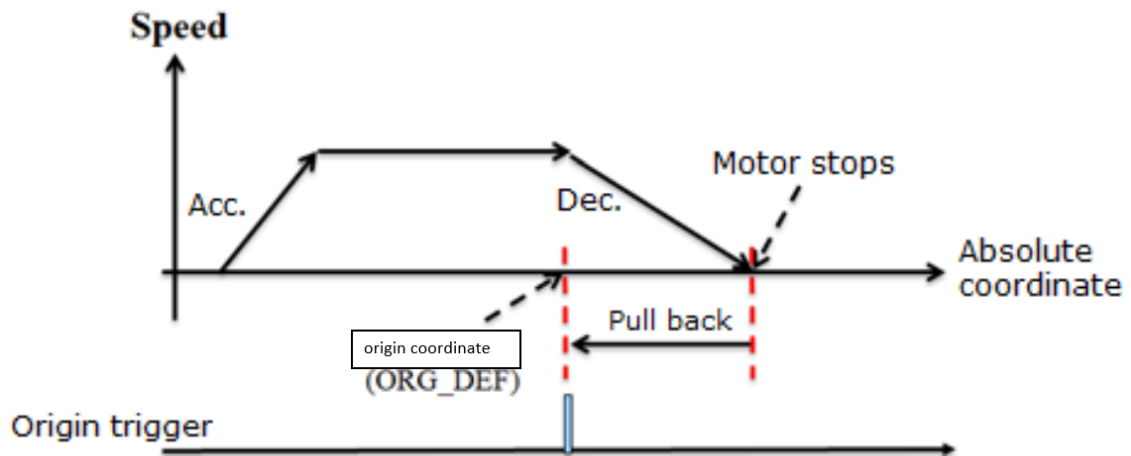

If returning to the origin is not needed, set PATH to 0.

If returning to the origin is needed, set PATH=A , and it will execute PATH#A automatically after homing and set absolute positioning command =ORG_DEF.

The homing does not define an offset value (Offset), but uses PATH to specify a path as the offset value! It is recommended to use absolute positioning command for this path, and the command value = offset (value of absolute coordinates).

7.4 PR sequence status

In PR, all 63 groups of programs can be set to five control types: constant speed, positioning, path jump, parameter writing and index positioning. With this 63 program to perform various control combinations according to the settings, SDC servo PR provides three sequences. Every PR could be linked to the other PR with one of 3 sequences: AUTO (automatically execute the next program), interrupt (INS) and overlap (OVLP). Among them, AUTO and interrupt can be set in the all five control types, but the overlap function can only be used for switching position functions. The following is an description of the three different sequences:

Sequential command: If INS and OVLP is not set in PR, the program will follow the original setting sequence. If the previous program has set to AUTO sequences, the next program will add the delay time setting after the previous program completion.

Overlapping command: if the previous and next program are both positioning control program, overlap function can be set in the previous program to enable overlapping to the next positioning control, which will make the two positioning control be transited smoothly, and reduce the vibration during transition.

Interrupt command: It indicates that the current PR will immediately replace or combined by another command. The result of the final command will vary according to different control types.

Sequential command: Use the AUTO function to generate a fixed sequence of program command combinations.

PATH#12 (AUTO positioning control, incremental positioning path : 104857600 pulse, delay time: 200ms) → PATH#13(Positioning control, absolute positioning: 0 pulse).

As shown in the figure below, which is a typical sequential command of positioning control followed by positioning control. In positioning control, the delay time starts counting after the positioning is completed.

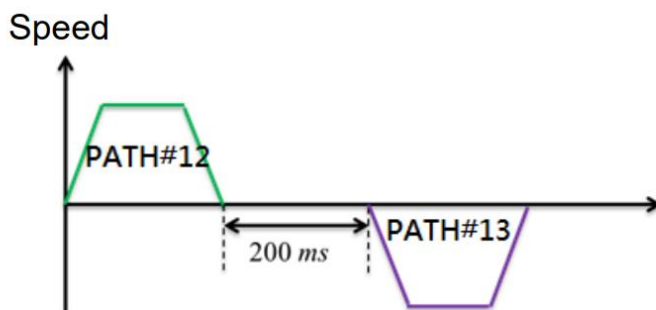

PATH#12(AUTO constant speed control, target speed : 2000 rpm, delay time: 200ms) → PATH#13 (Positioning control, absolute positioning:0 pulse)

As shown in the figure below, it is a typical sequential command of constant speed control followed by positioning control. In speed control, the delay time will start counting after the positioning is completed

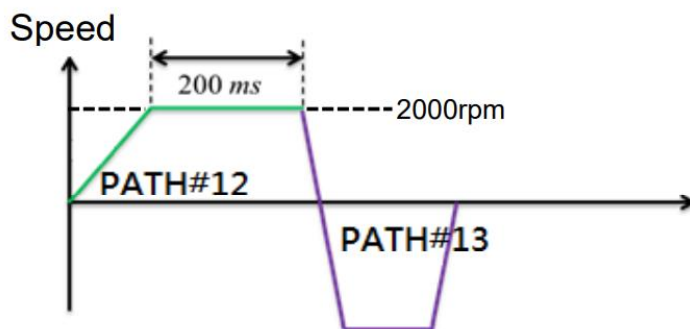

Overlapping command: In the sequential command, if positioning control is followed by positioning control, the previous positioning will control the overlapping of the next positioning control commands. Overlap is that the acceleration of next command overlaps the deceleration of previous command immediately, and this 2 positioning control can be smoothly transitioned.

PATH#12(AUTO positioning control, overlapping, incremental positioning path: 104857600 pulse, target speed: 500 rpm, ACC: 400 ms) → PATH#13(Positioning control, incremental positioning path: 104857600 pulse, target speed: 700 rpm, delay time: 0 ms, DEC: 200 ms).

From the figure below, it can be observed that the two positioning commands can be transitioned very smoothly by the overlap function, and the speed jitter during program switching is reduced.

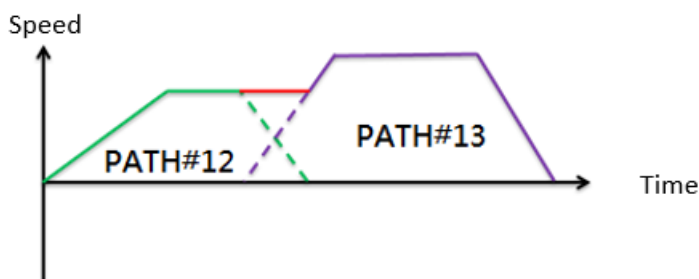

INS command: it can be set in any control type, and it is set in the next program. SDC PR contains internal INS and external INS.

Internal INS: which is a sequential command and its next program has set interrupts. The biggest difference from the sequential command is the definition of the delay time. The delay time of sequential commands is calculated from reaching the target position or target speed, but internal INS is calculated from the beginning of the previous program, as shown in the following example.

PATH#12(AUTO positioning control, incremental positioning path: 10485760 pulse, target speed: 600 rpm, delay time: 1500 ms, ACC: 200 ms, DEC: 200 ms) → PATH#13(Positioning control, with INS command, incremental positioning path: -10485760 pulse, target speed: 600 rpm, delay time: 0 ms, ACC: 200 ms, DEC: 200 ms).

The execution result of this program is shown in the figure below, and it makes the entire control program to manage time easily with the internal interruption.

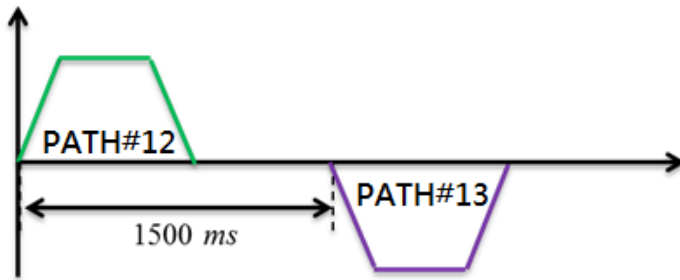

The delay time of internal INS should not be less than the completion time of the program, otherwise it will interrupt by the next program before the previous program is completed, as shown in the figure below:

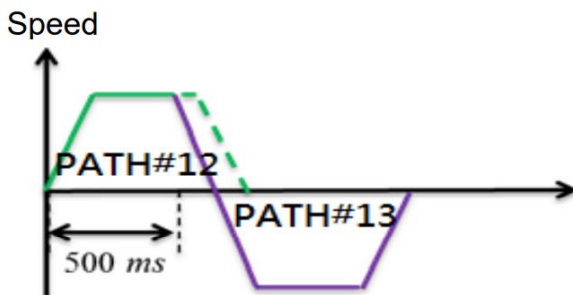

External INS: The biggest difference between internal and external INS is that the latter part is triggered by the program with INS. The former is planned by sequential commands, but the latter is executed by external triggers. In addition, the delay time setting in the previous program is invalid when the external interrupt occurs. As shown in below example:

PATH#12(AUTO positioning control, incremental positioning path: 10485760 pulse, target speed: 600 rpm, delay time: 1500 ms, ACC: 200 ms, DEC: 200 ms) → PATH#13(Positioning control, with INS, incremental positioning path: -10485760 pulse, target speed: 600 rpm, delay time: 0 ms, ACC: 200 ms, DEC: 200 ms) .

The above is a preset program control flow, if an external DI triggers PATH#07 during 400ms operation (positioning control, with INS, absolute positioning coordinate: 0 pulse, target speed: 3000 rpm, delay time: 0 ms, ACC: 200 ms, DEC: 200 ms), the execution result of the program is shown in below. Once the external INS occurs, the external INS program will replace the original sequential command and execute immediately, so the external interruption can be used for an emergency treatment.

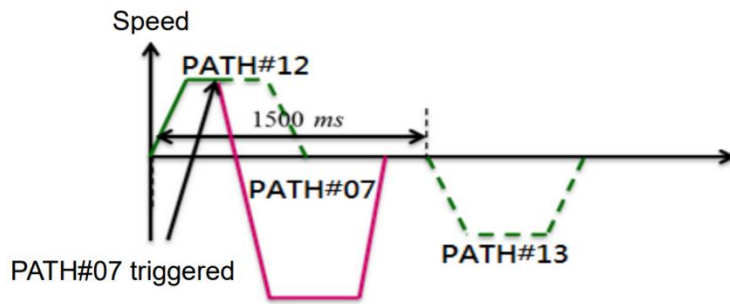

In addition, if a new program is externally triggered during a program is in progress and it is not set as interruption, you must wait for the complete of the executing program before starting the triggered program, as shown in the figure below

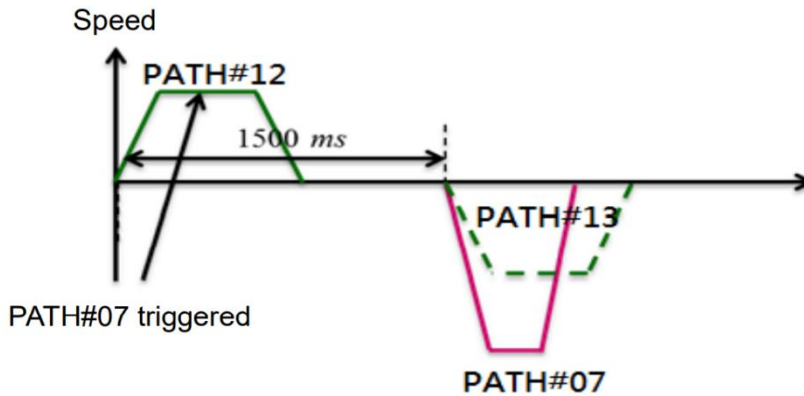

8. Parameter setting

8.1 Parameter definitions

From the perspective of safety and frequency of use, Shihlin drive parameters have below types: basic parameters, gain/filter parameters, expansion parameters, and input/output setting parameters. When you want to adjust parameter reading and writing permissions, you can modify the setting of PA42 to change the setting of expansion parameters.

The following are the precautions of parameter setting.

1. Parameter type classification

In section 8.2, parameters are classified into a parameter list according to its function for the users to use conveniently. For detailed parameter descriptions you can refer to section 8.3.

2. Special symbols for parameter codes

(■) the setting is vanished once power off.

(*) the setting is valid after restart the power, such as PA01.

(▲) the parameter cannot be changed when Servo ON, such as PA07. And there are 2 ways to switch off the servo.

(1) Turn off the SON DI signal.

(2) Change the SON signal setting to 0 in software terminal function by modifying PD16 , but ensure to reset PD16 after completion of the modification.

Below is the group classification according to different functions.

Parameter group	Main content.
Basic parameter (No PA□□)	When the servo drive is used for position control, you need to set this parameter group.
Gain, filter parameter (No PB□□)	When using manual tuning gain adjustment, you need to set this parameter group.
Expansion setting parameter (No PC□□)	This is the main parameter group used when speed control and torque control mode is used.

Input /output setting parameter (No PD□□)	Used when the output/input signal of the servo drive is changed.
Pr path parameter 1 (No PE□□)	Related parameter group 1 for Pr position path planning.
Pr path parameter 2 (No PF□□)	Related parameter group 2 for Pr position path planning.

The description of control mode as follows.

Mode name		Mode code	Description
Single mode	Position mode(external input)	Pt	Drive receives the external position pulse command which is input from terminal , then runs the motor to reach the target position.
	Position mode(internal register input)	Pr	The drive receives the position command which is provided by the internal register (64 groups of registers), and runs the motor to the target position. The DI signal can be used to select the register number.
	Speed mode.	S	The drive receives the speed command and runs the motor to the target speed. The speed command can be selected by the DI signal(7 groups of register).
	Torque mode.	T	The drive receives torque command which is provided by three groups of internal torque commands and runs the motor to the target torque.
Dual mode		Pt-S	Pt/S is switched mutually via the signal of DI.
		Pt-T	Pt/T is switched mutually via the signal of DI.
		Pr-S	Pr/S is switched mutually via the signal of DI.
		Pr-T	Pr/T is switched mutually via the signal of DI.
		S-T	S/T is switched mutually via the signal of DI.

8.2 List of Parameters

The parameters of Shihlin servo are mainly classified into five categories, they are PA parameter group ~ PF parameter group. PA parameters are basic parameters, such as control mode selection, automatic tuning, etc. The PB parameters are gain and filter parameters. Setting the PB parameters can make the servo motor to run in a more stable state. PC parameters are expansion parameters, which include parameters for speed mode, torque mode, and communication setting. PD parameters are input and output setting parameters, which are mainly used to set the parameters of DI and DO function. PE and PF parameters are Pr path planning related parameter. The following table will list all the parameters of Shihlin servo drive for users to query conveniently.

(1) Basic parameters

NO	Abbreviation	Name	Default value	Unit	Control mode			
					Pt	Pr	S	T
PA01(*)	STY	Control mode setting	1000h	N/A	<input type="radio"/>	<input type="radio"/>	<input type="radio"/>	<input type="radio"/>
PA02(▲)	ATUM	AUTO tuning mode setting	0002h	N/A	<input type="radio"/>	<input type="radio"/>	<input type="radio"/>	<input type="radio"/>
PA03	ATUL	Auto-tuning response level setting	10	N/A	<input type="radio"/>	<input type="radio"/>	<input type="radio"/>	<input type="radio"/>
PA04	HMOV	Homing mode	0000h	N/A		<input type="radio"/>		
PA05	TL1	Internal torque limit 1	100	%	<input type="radio"/>	<input type="radio"/>	<input type="radio"/>	<input type="radio"/>
PA06	CMX	Electronic gear numerator	1	N/A	<input type="radio"/>	<input type="radio"/>		
PA07(▲)	CDV	Electronic gear denominator	1	N/A	<input type="radio"/>	<input type="radio"/>		
PA08	HSPD1	Homing high speed option 1	100	rpm		<input type="radio"/>		
PA09	HSPD2	Homing high speed option 2	20	rpm		<input type="radio"/>		
PA10	RES1	Regenerated resistor value	Depend on model	Ohm	<input type="radio"/>	<input type="radio"/>	<input type="radio"/>	<input type="radio"/>
PA11	RES2	Regenerated resistor capacity		Watt	<input type="radio"/>	<input type="radio"/>	<input type="radio"/>	<input type="radio"/>
PA12	INP	In-position range	1310	Pulse	<input type="radio"/>	<input type="radio"/>		
PA13(*)	PLSS	Command pulse option	0000h	N/A	<input type="radio"/>			

NO	Abbreviation	Name	Default value	Unit	Control mode			
					Pt	Pr	S	T
PA14(*)	ENR	Encoder output pulses	10000	Pulse/rev	○	○	○	○
PA15	CRSHA	Motor crash protect level(torque percentage)	250	%	○	○	○	○
PA16	CRSHT	Motor crash protect level (protection time)	500	ms	○	○	○	○
PA17	OVL	Output overload DO warning level	120	%	○	○	○	○
PA18	OVS	Over speed warning level	6300	rpm	○	○	○	○
PA19	OVPE	Position deviation excess output level	$3 \cdot 2^{17}$	pulse	○	○		
PA20(*)	OVPL1	Position pulse frequency excess level 1	4500	KHz	○			
PA21(*)		Reserved						
PA22(*)	DBF	Dynamic brake control	0	N/A	○	○	○	○
PA23(■)	MCS	Memory write-inhibit function	0	N/A	○	○	○	○
PA24 ~PA27		Reserved						
PA28(*)	ABS	Absolute encoder settings	0000h	N/A	○	○	○	○
PA29(■)	CAP	Absolute homing position	0000h	N/A	○	○	○	○
PA30(■)	UAP	Update encoder absolute position	0	N/A	○	○	○	○
PA31	APST	Absolute coordinate system status	0000h	N/A	○	○	○	○
PA32	APR	Encoder absolute position (Single-turn pulse number)	0	pulse	○	○	○	○
PA33	APP	Encoder absolute position (number of revolutions)	0	rev	○	○	○	○
PA34(*)	ABSM	I/O communication of absolute system	0	N/A	○	○	○	○
PA35(*)	FNO1	Function option 1	0000h	N/A	○	○	○	○
PA36(*)	FNO2	Function option 2	0000h	N/A	○	○	○	○

NO	Abbreviation	Name	Default value	Unit	Control mode			
					Pt	Pr	S	T
PA37(*)	FNO3	Function option 3	0000h	N/A	○	○	○	○
PA38	AOP3	One touch gain tuning function option	0000h	N/A	○	○	○	
PA39(*)	POL	Motor rotation direction option	0000h	N/A	○	○	○	○
PA40(▲)	SPW	Special parameter write option	0000h	N/A	○	○	○	○
PA41	POSPD	Max. speed setting of pulse output	6300	rpm	○	○	○	○
PA42(*)	BLK	Parameter write-inhibit	0000h	N/A	○	○	○	○
PA43(*)	ENB	Encoder type(read only)	N/A	N/A	○	○	○	○
PA44(*)	EGM	Electronic gear ratio option	0	N/A	○	○		
PA45(▲)	FBP	Position command pulse setting per turn	10000	Pulse	○	○		
PA46	ATST	One touch gain tuning option (factory setting, inhibit to use)	0000h	N/A	○	○	○	
PA47	TLP	Positive torque limit value	5000	0. 1%	○	○	○	○
PA48	TLN	Negative torque limit value	5000	0. 1%	○	○	○	○
PA49 ~PA50		Reserved						
PA44(*)	EGM	Electronic gear ratio option	0	N/A	○	○		
PA45(▲)	FBP	Position command pulse setting per turn	10000	Pulse	○	○		
PA46	ATST	One touch gain tuning option (factory setting, inhibit to use)	0000h	N/A	○	○	○	
PA47	TLP	Positive torque limit value	5000	0. 1%	○	○	○	○
PA48	TLN	Negative torque limit value	5000	0. 1%	○	○	○	○
PA49 ~PA50		Reserved						

(2) Gain, filter parameters

NO	Abbreviation	Name	Default value	Unit	Control mode			
					Pt	Pr	S	T
PB01	NHF1	Frequency of Machine resonance suppression filter 1	1000	Hz	<input type="radio"/>	<input type="radio"/>	<input type="radio"/>	<input type="radio"/>
PB02	NHD1	Attenuation rate of machine resonance suppression filter 1	0	dB	<input type="radio"/>	<input type="radio"/>	<input type="radio"/>	<input type="radio"/>
PB03	NLP	Resonance suppression low-pass filter	17	0. 1ms	<input type="radio"/>	<input type="radio"/>	<input type="radio"/>	<input type="radio"/>
PB04	PST	Position command filter time constant	3	ms	<input type="radio"/>	<input type="radio"/>		
PB05	FFC	Position feed-forward gain	0	0. 0001	<input type="radio"/>	<input type="radio"/>		
PB06	GD1	Servo motor load inertia ratio	70	0. 1 time	<input type="radio"/>	<input type="radio"/>	<input type="radio"/>	
PB07	PG1	Position loop gain	45	rad/s	<input type="radio"/>	<input type="radio"/>		
PB08	VG1	Speed loop gain	183	rad/s	<input type="radio"/>	<input type="radio"/>	<input type="radio"/>	
PB09	VIC	Speed integral gain	34	ms	<input type="radio"/>	<input type="radio"/>	<input type="radio"/>	
PB10	VFG	Speed feed-forward gain	0	%			<input type="radio"/>	
PB11(*)	CDP	Gain switch option	0000h	N/A	<input type="radio"/>	<input type="radio"/>	<input type="radio"/>	
PB12	CDS	Gain switch condition	10	kpps/rpm/pulse	<input type="radio"/>	<input type="radio"/>	<input type="radio"/>	
PB13	CDT	Gain switch time constant	1	ms	<input type="radio"/>	<input type="radio"/>	<input type="radio"/>	
PB14	GD2	Servo motor load inertia ratio 2	70	0. 1time	<input type="radio"/>	<input type="radio"/>	<input type="radio"/>	
PB15	PG2	Position loop gain change ratio	100	%	<input type="radio"/>	<input type="radio"/>		
PB16	VG2	Speed loop gain change ratio	100	%	<input type="radio"/>	<input type="radio"/>	<input type="radio"/>	
PB17	VIC2	Speed integral gain change ratio	100	%	<input type="radio"/>	<input type="radio"/>	<input type="radio"/>	

NO	Abbreviation	Name	Default value	Unit	Control mode			
					Pt	Pr	S	T
PB18	SFLT	Speed command low-pass filter smooth time constant	0	ms			○	○
PB19	TQC	Torque command filter time constant	0	ms				○
PB20	SJIT	Speed feedback filter time constant	0	0.1ms	○	○	○	○
PB21	NHF2	Frequency of machine resonance suppression filter 2	1000	Hz	○	○	○	○
PB22	NHD2	Attenuation of machine resonance suppression filter 2	0	dB	○	○	○	○
PB23(▲)	IGE	Current gain enhancement function	0	N/A	○	○	○	○
PB24	VDC	Speed differential compensation	980	N/A	○	○	○	
PB25	NHF3	Frequency of machine resonance suppression filter 3	1000	Hz	○	○	○	○
PB26	NHD3	Attenuation of machine resonance suppression filter 3	0	dB	○	○	○	○
PB27	ANCF	Auto resonance suppression mode setting	0	N/A	○	○	○	○
PB28	ANCL	Auto resonance suppression detection level	50	%	○	○	○	○
PB29	AVSM	Auto low frequency vibration suppression mode	0	N/A	○	○		
PB30	VCL	Low-frequency vibration detection level setting	50	pulse	○	○		

NO	Abbreviation	Name	Default value	Unit	Control mode			
					Pt	Pr	S	T
PB31	VSF1	Low frequency vibration suppression frequency setting 1	100	0. 1Hz	<input type="radio"/>	<input type="radio"/>		
PB32	VSG1	Low frequency vibration suppression gain 1	0	N/A	<input type="radio"/>	<input type="radio"/>		
PB33	VSF2	Low frequency vibration suppression frequency setting 2	100	0. 1Hz	<input type="radio"/>	<input type="radio"/>		
PB34	VSG2	Low frequency vibration suppression gain 2	0	N/A	<input type="radio"/>	<input type="radio"/>		
PB35	FRCL	Friction compensation level	0	%	<input type="radio"/>	<input type="radio"/>	<input type="radio"/>	
PB36	FRCT	Friction compensation smoothing time constant	0	ms	<input type="radio"/>	<input type="radio"/>	<input type="radio"/>	
PB37	FRCM	Friction compensation mode option	0	N/A	<input type="radio"/>	<input type="radio"/>	<input type="radio"/>	
PB38	FFCT	Position feed forward filter time constant	0	ms	<input type="radio"/>	<input type="radio"/>		
PB39 ~PB43		Reserved						
PB44	PPD	Position loop compensation gain	0	rad/s	<input type="radio"/>	<input type="radio"/>		
PB45	NHF4	Frequency of machine resonance suppression filter 4	1000	Hz	<input type="radio"/>	<input type="radio"/>	<input type="radio"/>	<input type="radio"/>
PB46	NHD4	Attenuation of machine resonance suppression filter 4	0	dB	<input type="radio"/>	<input type="radio"/>	<input type="radio"/>	<input type="radio"/>
PB47	NHF5	Frequency of machine resonance suppression filter 5	1000	Hz	<input type="radio"/>	<input type="radio"/>	<input type="radio"/>	<input type="radio"/>
PB48	NHD5	Attenuation of machine resonance	0	dB	<input type="radio"/>	<input type="radio"/>	<input type="radio"/>	<input type="radio"/>

		suppression filter 5							
PB49	DOB	External interference compensation gain	0	N/A	<input type="radio"/>	<input type="radio"/>	<input type="radio"/>	<input type="radio"/>	<input type="radio"/>
PB50	MVF	Position command average filter time constant	0	ms	<input type="radio"/>	<input type="radio"/>			
PB51 ~PB26		Reserved for factory test only.							
PB57(*)	TOF	z-axis torque compensation	0	0.1%	<input type="radio"/>	<input type="radio"/>	<input type="radio"/>	<input type="radio"/>	<input type="radio"/>

(3) Expansion parameters

NO	Abbreviation	Name	Default value	Unit	Control mode			
					Pt	Pr	S	T
PC01	STA	Acceleration time constant	200	ms		<input type="radio"/>	<input type="radio"/>	<input type="radio"/>
PC02	STB	Deceleration time constant	200	ms		<input type="radio"/>	<input type="radio"/>	<input type="radio"/>
PC03	STC	S-curve acceleration/deceleration time constant	0	ms		<input type="radio"/>	<input type="radio"/>	<input type="radio"/>
PC04	JOG	JOG speed command	300	rpm	<input type="radio"/>	<input type="radio"/>	<input type="radio"/>	<input type="radio"/>
PC05	SC1	Internal speed command 1	100	rpm			<input type="radio"/>	<input type="radio"/>
PC06	SC2	Internal speed command 2	500	rpm			<input type="radio"/>	<input type="radio"/>
PC07	SC3	Internal speed command 3	1000	rpm			<input type="radio"/>	<input type="radio"/>
PC08	SC4	Internal speed command 4	200	rpm			<input type="radio"/>	<input type="radio"/>
PC09	SC5	Internal speed command 5	300	rpm			<input type="radio"/>	<input type="radio"/>
PC10	SC6	Internal speed command 6	500	rpm			<input type="radio"/>	<input type="radio"/>
PC11	SC7	Internal speed command7	800	rpm			<input type="radio"/>	<input type="radio"/>
PC16	MBR	Electromagnetic brake sequence output time	100	ms	<input type="radio"/>	<input type="radio"/>	<input type="radio"/>	<input type="radio"/>
PC17	ZSP	Zero speed signal acknowledged range	50	rpm	<input type="radio"/>	<input type="radio"/>	<input type="radio"/>	<input type="radio"/>
PC18(*)	COP1	Stop option and power interruption and restart option	0010h	N/A	<input type="radio"/>	<input type="radio"/>	<input type="radio"/>	<input type="radio"/>
PC19(*)	COP2	Alarm record clear option	0000h	N/A	<input type="radio"/>	<input type="radio"/>	<input type="radio"/>	<input type="radio"/>
PC20(*)	SNO	Servo drive communication device number	1	N/A	<input type="radio"/>	<input type="radio"/>	<input type="radio"/>	<input type="radio"/>

NO	Abbreviation	Name	Default value	Unit	Control mode			
					Pt	Pr	S	T
PC21(*)	CMS	Communication mode option	0	N/A	○	○	○	○
PC22(*)	BPS	Communication protocol option	0010h	N/A	○	○	○	○
PC23	SIC	Serial communication timeout option	0	s	○	○	○	○
PC24(*)	DMD	Drive status display option	0000h	N/A	○	○	○	○
PC25	TL2	Internal torque limit 2	100	%	○	○	○	○
PC26 ~ PC31		Reserved						
PC32	CMX2	Electronic gear numerator 2	1	N/A	○			
PC33	CMX3	Electronic gear numerator 3	1	N/A	○			
PC34	CMX4	Electronic gear numerator 4	1	N/A	○			
PC37(*)	DTA9	AL.09 initialization delay judgement time	0	ms	○	○	○	○
PC38	FNO4	Function option4	0000h	N/A	○	○	○	○
PC39	LPS	Low-pass filter setting option	0000h	N/A	○	○	○	○
PC40	MBR1	Electromagnetic brake enable delay time	0	ms	○	○	○	○
PC41	MP1A	Object parameter PC57 mapping	0000h	N/A	○	○	○	○
PC42	MP2A	Object parameter PC58 mapping	0000h	N/A	○	○	○	○
PC43	MP3A	Object parameter PC59 mapping	0000h	N/A	○	○	○	○
PC44	MP4A	Object parameter PC60 mapping	0000h	N/A	○	○	○	○
PC45	MP5A	Object parameter PC61 mapping	0000h	N/A	○	○	○	○
PC46	MP6A	Object parameter PC62 mapping	0000h	N/A	○	○	○	○
PC47	MP7A	Object parameter PC63 mapping	0000h	N/A	○	○	○	○
PC48	MP8A	Object parameter PC64 mapping	0000h	N/A	○	○	○	○
PC49	MS1A	Object status display 1 mapping	0000h	N/A	○	○	○	○
PC50	MS2A	Object status display 2 mapping	0000h	N/A	○	○	○	○

NO	Abbreviation	Name	Default value	Unit	Control mode			
					Pt	Pr	S	T
PC51	MS3A	Object status display 3 mapping	0000h	N/A	○	○	○	○
PC52	MS4A	Object status display 4 mapping	0000h	N/A	○	○	○	○
PC53	MS5A	Object status display 5 mapping	0000h	N/A	○	○	○	○
PC54 ~PC56		Reserved						
PC57	MP1	Mapping parameter #1	0000h	N/A	○	○	○	○
PC58	MP2	Mapping parameter #2	0000h	N/A	○	○	○	○
PC59	MP3	Mapping parameter #3	0000h	N/A	○	○	○	○
PC60	MP4	Mapping parameter #4	0000h	N/A	○	○	○	○
PC61	MP5	Mapping parameter #5	0000h	N/A	○	○	○	○
PC62	MP6	Mapping parameter #6	0000h	N/A	○	○	○	○
PC63	MP7	Mapping parameter #7	0000h	N/A	○	○	○	○
PC64	MP8	Mapping parameter #8	0000h	N/A	○	○	○	○
PC65	MS1	The content value of mapping status 1	0	N/A	○	○	○	○
PC66	MS2	The content value of mapping status 2	0	N/A	○	○	○	○
PC67	MS3	The content value of mapping status 3	0	N/A	○	○	○	○
PC68	MS4	The content value of mapping status 4	0	N/A	○	○	○	○
PC69	MS5	The content value of mapping status 5	0	N/A	○	○	○	○
PC70 ~PC72		Reserved						
PC73	TQ1	Internal torque command 1	100	%				○
PC74	TQ2	Internal torque command 2	100	%				○
PC75	TQ3	Internal torque command 3	100	%				○

(4) Input/output setting parameters

NO	Abbreviation	Name	Default value	Unit	Control mode			
					Pt	Pr	S	T
PD01(*)	DIA1	Input signal automatic ON option 1	0000h	N/A	○	○	○	○
PD02(*)	DI1	Input signal option 1	0001h	N/A	○	○	○	○
PD03(*)	DI2	Input signal option 2	000Dh	N/A	○	○	○	○
PD04(*)	DI3	Input signal option 3	0003h	N/A	○	○	○	○
PD05(*)	DI4	Input signal option 4	0004h	N/A	○	○	○	○
PD06(*)	DI5	Input signal option 5	0002h	N/A	○	○	○	○
PD07(*)	DI6	Input signal option 6	000Fh	N/A	○	○	○	○
PD08(*)	DI7	Input signal option 7	0012h	N/A	○	○	○	○
PD09(*)	DI8	Input signal option 8	0019h	N/A	○	○	○	○
PD10(*)	DO1	Output signal option 1	0003h	N/A	○	○	○	○
PD11(*)	DO2	Output signal option 2	0008h	N/A	○	○	○	○
PD12(*)	DO3	Output signal option 3	0002h	N/A	○	○	○	○
PD13(*)	DO4	Output signal option 4	0005h	N/A	○	○	○	○
PD14(*)	DO5	Output signal option 5	0001h	N/A	○	○	○	○
PD15(*)	DIF	Digital input filter setting	2	N/A	○	○	○	○
PD16(■)	IOS	Digital input control source option	0000h	N/A	○	○	○	○
PD17(*)	DOP1	LSP, LSN stop mode option	0000h	N/A	○	○	○	
PD18(*)	DOP2	CR signal clear setting	0000h	N/A	○	○		
PD19(*)	DOP3	Alarm code output option	0000h	N/A	○	○	○	○
PD20(*)	DOP4	Operation option when the alarm reset signal is short-circuited	0000h	N/A	○	○	○	○
PD21(*)	DI9	Input signal option 9	0018h	N/A	○	○	○	○
PD22 ~ PD24		Reserved						
PD25(■)	ITST	Communication control digital input status	0000h	N/A	○	○	○	○
PD26(*)		Reserved						
PD27(*)	DOD	Definition of output signal contact	0004h	N/A	○	○	○	○
PD28	MCOK	Operation option of DO: MC_OK	0000h	N/A		○		

NO	Abbreviation	Name	Default value	Unit	Control mode			
					Pt	Pr	S	T
PD29	DID	Software DI A/B contact setting	0000h	N/A	○	○	○	○
PD30		Reserved						
PD31		Reserved						
PD32(*)	SDLY	Servo ON delay time	0	N/A	○	○	○	○
PD33	SFDO	Software DO register	0000h	N/A	○	○	○	○

(5) PR position path programming parameters 1

NO	Abbreviation	Name	Default value	Unit	Control mode			
					Pt	Pr	S	T
PE01	ODEF	Definition of homing	00000000h	N/A		○		
PE02	ODAT	Origin offset value definition	0	N/A		○		
PE03	PDEF1	PATH#1 definition	00000000h	N/A		○		
PE04	PDAT1	PATH#1 data	0	N/A		○		
PE05	PDEF2	PATH#2 definition	00000000h	N/A		○		
PE06	PDAT2	PATH#2 data	0	N/A		○		
PE07	PDEF3	PATH#3 definition	00000000h	N/A		○		
PE08	PDAT3	PATH#3 data	0	N/A		○		
PE09	PDEF4	PATH#4 definition	00000000h	N/A		○		
PE10	PDAT4	PATH#4 data	0	N/A		○		
PE11	PDEF5	PATH#5 definition	00000000h	N/A		○		
PE12	PDAT5	PATH#5 data	0	N/A		○		
PE13	PDEF6	PATH#6 definition	00000000h	N/A		○		
PE14	PDAT6	PATH#6 data	0	N/A		○		
PE15	PDEF7	PATH#7 definition	00000000h	N/A		○		
PE16	PDAT7	PATH#7 data	0	N/A		○		
PE17	PDEF8	PATH#8 definition	00000000h	N/A		○		
PE18	PDAT8	PATH#8 data	0	N/A		○		
PE19	PDEF9	PATH#9 definition	00000000h	N/A		○		
PE20	PDAT9	PATH#9 data	0	N/A		○		
PE21	PDEF10	PATH#10 definition	00000000h	N/A		○		
PE22	PDAT10	PATH#10 data	0	N/A		○		
PE23	PDEF11	PATH#11 definition	00000000h	N/A		○		
PE24	PDAT11	PATH#11 data	0	N/A		○		
PE25	PDEF12	PATH#12 definition	00000000h	N/A		○		

PE26	PDAT12	PATH#12 data	0	N/A		○		
NO	Abbreviation	Name	Default value	Unit	Control mode			
					Pt	Pr	S	T
PE27	PDEF13	PATH#13 definition	00000000h	N/A		○		
PE28	PDAT13	PATH#13 data	0	N/A		○		
PE29	PDEF14	PATH#14 definition	00000000h	N/A		○		
PE30	PDAT14	PATH#14 data	0	N/A		○		
PE31	PDEF15	PATH#15 definition	00000000h	N/A		○		
PE32	PDAT15	PATH#15 data	0	N/A		○		
PE33	PDEF16	PATH#16 definition	00000000h	N/A		○		
PE34	PDAT16	PATH#16 data	0	N/A		○		
PE35	PDEF17	PATH#17 definition	00000000h	N/A		○		
PE36	PDAT17	PATH#17 data	0	N/A		○		
PE37	PDEF18	PATH#18 definition	00000000h	N/A		○		
PE38	PDAT18	PATH#18 data	0	N/A		○		
PE39	PDEF19	PATH#19 definition	00000000h	N/A		○		
PE40	PDAT19	PATH#19 data	0	N/A		○		
PE41	PDEF20	PATH#20 definition	00000000h	N/A		○		
PE42	PDAT20	PATH#20 data	0	N/A		○		
PE43	PDEF21	PATH#21 definition	00000000h	N/A		○		
PE44	PDAT21	PATH#21 data	0	N/A		○		
PE45	PDEF22	PATH#22 definition	00000000h	N/A		○		
PE46	PDAT22	PATH#22 data	0	N/A		○		
PE47	PDEF23	PATH#23 definition	00000000h	N/A		○		
PE48	PDAT23	PATH#23 data	0	N/A		○		
PE49	PDEF24	PATH#24 definition	00000000h	N/A		○		
PE50	PDAT24	PATH#24 data	0	N/A		○		
PE51	PDEF25	PATH#25 definition	00000000h	N/A		○		
PE52	PDAT25	PATH#25 data	0	N/A		○		
PE53	PDEF26	PATH#26 definition	00000000h	N/A		○		
PE54	PDAT26	PATH#26 data	0	N/A		○		
PE55	PDEF27	PATH#27 definition	00000000h	N/A		○		
PE56	PDAT27	PATH#27 data	0	N/A		○		
PE57	PDEF28	PATH#28 definition	00000000h	N/A		○		
PE58	PDAT28	PATH#28 data	0	N/A		○		
PE59	PDEF29	PATH#29 definition	00000000h	N/A		○		
PE60	PDAT29	PATH#29 data	0	N/A		○		

PE61	PDEF30	PATH#30 definition	00000000h	N/A		○		
NO	Abbreviation	Name	Default value	Unit	Control mode			
					Pt	Pr	S	T
PE62	PDAT30	PATH#30 data	0	N/A		○		
PE63	PDEF31	PATH#31 definition	00000000h	N/A		○		
PE64	PDAT31	PATH#31 data	0	N/A		○		
PE65	PDEF32	PATH#32 definition	00000000h	N/A		○		
PE66	PDAT32	PATH#32 data	0	N/A		○		
PE67	PDEF33	PATH#33 definition	00000000h	N/A		○		
PE68	PDAT33	PATH#33 data	0	N/A		○		
PE69	PDEF34	PATH#34 definition	00000000h	N/A		○		
PE70	PDAT34	PATH#34 data	0	N/A		○		
PE71	PDEF35	PATH#35 definition	00000000h	N/A		○		
PE72	PDAT35	PATH#35 data	0	N/A		○		
PE73	PDEF36	PATH#36 definition	00000000h	N/A		○		
PE74	PDAT36	PATH#36 data	0	N/A		○		
PE75	PDEF37	PATH#37 definition	00000000h	N/A		○		
PE76	PDAT37	PATH#37 data	0	N/A		○		
PE77	PDEF38	PATH#38 definition	00000000h	N/A		○		
PE78	PDAT38	PATH#38 data	0	N/A		○		
PE79	PDEF39	PATH#39 definition	00000000h	N/A		○		
PE80	PDAT39	PATH#39 data	0	N/A		○		
PE81	PDEF40	PATH#40 definition	00000000h	N/A		○		
PE82	PDAT40	PATH#40 data	0	N/A		○		
PE83	PDEF41	PATH#41 definition	00000000h	N/A		○		
PE84	PDAT41	PATH#41 data	0	N/A		○		
PE85	PDEF42	PATH#42 definition	00000000h	N/A		○		
PE86	PDAT42	PATH#42 data	0	N/A		○		
PE87	PDEF43	PATH#43 definition	00000000h	N/A		○		
PE88	PDAT43	PATH#43 data	0	N/A		○		
PE89	PDEF44	PATH#44 definition	00000000h	N/A		○		
PE90	PDAT44	PATH#44 data	0	N/A		○		
PE91	PDEF45	PATH#45 definition	00000000h	N/A		○		
PE92	PDAT45	PATH#45 data	0	N/A		○		
PE93	PDEF46	PATH#46 definition	00000000h	N/A		○		
PE94	PDAT46	PATH#46 data	0	N/A		○		
PE95	PDEF47	PATH#47 definition	00000000h	N/A		○		

PE96	PDAT47	PATH#47 data	0	N/A		○		
NO	Abbreviation	Name	Default value	Unit	Control mode			
					Pt	Pr	S	T
PE97	PDEF48	PATH#48 definition	00000000h	N/A		○		
PE98	PDAT48	PATH#48 data	0	N/A		○		
PE99		Reserved						

(6) PR position path programming parameters 2

NO	Abbreviation	Name	Default value	Unit	Control mode			
					Pt	Pr	S	T
PF01	PDEF49	PATH#49 definition	00000000h	N/A		○		
PF02	PDAT49	PATH#49 data	0	N/A		○		
PF03	PDEF50	PATH#50 definition	00000000h	N/A		○		
PF04	PDAT50	PATH#50 data	0	N/A		○		
PF05	PDEF51	PATH#51 definition	00000000h	N/A		○		
PF06	PDAT51	PATH#51 data	0	N/A		○		
PF07	PDEF52	PATH#52 definition	00000000h	N/A		○		
PF08	PDAT52	PATH#52 data	0	N/A		○		
PF09	PDEF53	PATH#53 definition	00000000h	N/A		○		
PF10	PDAT53	PATH#53 data	0	N/A		○		
PF11	PDEF54	PATH#54 definition	00000000h	N/A		○		
PF12	PDAT54	PATH#54 data	0	N/A		○		
PF13	PDEF55	PATH#55 definition	00000000h	N/A		○		
PF14	PDAT55	PATH#55 data	0	N/A		○		
PF15	PDEF56	PATH#56 definition	00000000h	N/A		○		
PF16	PDAT56	PATH#56 data	0	N/A		○		
PF17	PDEF57	PATH#57 definition	00000000h	N/A		○		
PF18	PDAT57	PATH#57 data	0	N/A		○		
PE19	PDEF58	PATH#58 definition	00000000h	N/A		○		
PF20	PDAT58	PATH#58 data	0	N/A		○		
PF21	PDEF59	PATH#59 definition	00000000h	N/A		○		
PF22	PDAT59	PATH#59 data	0	N/A		○		
PF23	PDEF60	PATH#60 definition	00000000h	N/A		○		
PF24	PDAT60	PATH#60 data	0	N/A		○		
PF25	PDEF61	PATH#61 definition	00000000h	N/A		○		
PF26	PDAT61	PATH#61 data	0	N/A		○		

NO	Abbreviation	Name	Default value	Unit	Control mode			
					Pt	Pr	S	T
PF27	PDEF62	PATH#61 definition	00000000h	N/A		○		
PF28	PDAT62	PATH#62 data	0	N/A		○		
PF29	PDEF63	PATH#63 definition	00000000h	N/A		○		
PF30	PDAT63	PATH#63 data	0	N/A		○		
PF31		Reserved						
PF32		Reserved						
PF33	POV1	Speed setting of internal position command 1	50	rpm		○		
PF34	POV2	Speed setting of internal position command 2	10	rpm		○		
PF35	POV3	Speed setting of internal position command 3	200	rpm		○		
PF36	POV4	Speed setting of internal position command 4	300	rpm		○		
PF37	POV5	Speed setting of internal position command 5	500	rpm		○		
PF38	POV6	Speed setting of internal position command 6	800	rpm		○		
PF39	POV7	Speed setting of internal position command 7	1000	rpm		○		
PF40	POV8	Speed setting of internal position command 8	1200	rpm		○		
PF41	POV9	Speed setting of internal position command 9	1500	rpm		○		
PF42	POV10	Speed setting of internal position command 10	1800	rpm		○		
PF43	POV11	Speed setting of internal position command 11	2000	rpm		○		
PF44	POV12	Speed setting of internal position command 12	2200	rpm		○		
PF45	POV13	Speed setting of internal position command 13	2400	rpm		○		
PF46	POV14	Speed setting of internal position command 14	2700	rpm		○		
PF47	POV15	Speed setting of internal position command 15	3000	rpm		○		

NO	Abbreviation	Name	Default value	Unit	Control mode			
					Pt	Pr	S	T
PF48	POV16	Speed setting of internal position command 16	3000	rpm		○		
PF49	POA1	Acceleration/deceleration time of internal position command 1	200	ms		○		
PF50	POA2	Acceleration/deceleration time of internal position command 2	300	ms		○		
PF51	POA3	Acceleration/deceleration time of internal position command 3	500	ms		○		
PF52	POA4	Acceleration/deceleration time of internal position command 4	600	ms		○		
PF53	POA5	Acceleration/deceleration time of internal position command 5	800	ms		○		
PF54	POA6	Acceleration/deceleration time of internal position command 6	900	ms		○		
PF55	POA7	Acceleration/deceleration time of internal position command 7	1000	ms		○		
PF56	POA8	Acceleration/deceleration time of internal position command 8	1200	ms		○		
PF57	POA9	Acceleration/deceleration time of internal position command 9	1400	ms		○		
PF58	POA10	Acceleration/deceleration time of internal position command 10	1600	ms		○		
PF59	POA11	Acceleration/deceleration time of internal position command 11	2000	ms		○		

NO	Abbreviation	Name	Default value	Unit	Control mode			
					Pt	Pr	S	T
PF60	POA12	Acceleration/deceleration time of internal position command 12	2500	ms		○		
PF61	POA13	Acceleration/deceleration time of internal position command 13	3000	ms		○		
PF62	POA14	Acceleration/deceleration time of internal position command 14	4000	ms		○		
PF63	POA15	Acceleration/deceleration time of internal position command 15	5000	ms		○		
PF64	POA16	Acceleration/deceleration time of internal position command 16	6000	ms		○		
PF65	DLY1	Delay time after position 1 reached	0	ms		○		
PF66	DLY2	Delay time after position 2 reached	100	ms		○		
PF67	DLY3	Delay time after position3 reached after position reached	200	ms		○		
PF68	DLY4	Delay time after position 4 reached	300	ms		○		
PF69	DLY5	Delay time after position 5 reached	500	ms		○		
PF70	DLY6	Delay time after position 6 reached	600	ms		○		
PF71	DLY7	Delay time after position 7 reached	800	ms		○		
PF73	DLY9	Delay time after position 9 reached	1200	ms		○		
PF74	DLY10	Delay time after position 10 reached	1500	ms		○		
PF75	DLY11	Delay time after position 11 reached	2000	ms		○		

NO	Abbreviation	Name	Default value	Unit	Control mode			
					Pt	Pr	S	T
PF76	DLY12	Delay time after position 12 reached	2300	ms		○		
PF77	DLY13	Delay time after position 13 reached	2500	ms		○		
PF78	DLY14	Delay time after position 1 reached	3000	ms		○		
PF79	DLY15	Delay time after position 14 reached	4000	ms		○		
PF80	DLY16	Delay time after position 15 reached	5000	ms		○		
PF81	PDEC	Deceleration time for auto-protection	00000000h	ms	○	○	○	○
PF82(■)	PRCM	PR command trigger register	0	N/A		○		
PF83	EVON	PR number triggered by event rising edge	0000h	N/A		○		
PF84	EVOF	PR number triggered by event falling edge	0000h	N/A		○		
PF85(■)	PMEM	PATH#1 to PATH#2 memory invalid	0000h	N/A	○	○	○	○
PF86	SWLP	Positive software limit	$2^{31}-1$	pulse	○	○		
PF87	SWLN	Negative software limit	$-2^{31}+1$	pulse	○	○		
PF88		Reserved						
PF89(*)	BLSF	Backlash compensation option	0	N/A	○	○		
PF90	BLSP	Backlash compensation setting(before E gears)	0	pulse	○	○		
PF91	BLST	Backlash compensation time constant setting	0	0.1m s	○	○		
PF92 ~ PF99		Reserved.						

To facilitate the user to operate the Shihlin servo with relevant parameters and set appropriate parameters in different modes, below listed the parameters by its categories.

Torque control relevant parameters								
Parameter code	Abbreviation	Function of parameter	Default value	Unit	Control mode			
					Pt	Pr	S	T
PA01(*)	STY	Control mode setting	1000h	N/A	<input type="radio"/>	<input type="radio"/>	<input type="radio"/>	<input type="radio"/>
PA05	TL1	Internal torque limit 1	100	%	<input type="radio"/>	<input type="radio"/>	<input type="radio"/>	<input type="radio"/>
PC05	SC1	Internal speed command 1	100	rpm			<input type="radio"/>	<input type="radio"/>
PC06	SC2	Internal speed command 2	500	rpm			<input type="radio"/>	<input type="radio"/>
PC07	SC3	Internal speed command 3	1000	rpm			<input type="radio"/>	<input type="radio"/>
PC08	SC4	Internal speed command 4	200	rpm			<input type="radio"/>	<input type="radio"/>
PC09	SC5	Internal speed command 5	300	rpm			<input type="radio"/>	<input type="radio"/>
PC10	SC6	Internal speed command 6	500	rpm			<input type="radio"/>	<input type="radio"/>
PC11	SC7	Internal speed command7	800	rpm			<input type="radio"/>	<input type="radio"/>
PC25	TL2	Internal torque limit 2	100	%	<input type="radio"/>	<input type="radio"/>	<input type="radio"/>	<input type="radio"/>
PC73	TQ1	Internal torque command 1	100	%				<input type="radio"/>
PC74	TQ2	Internal torque command 2	100	%				<input type="radio"/>
PC75	TQ3	Internal torque command 3	100	%				<input type="radio"/>
PA47	TLP	Positive torque limit value	5000	0.1%	<input type="radio"/>	<input type="radio"/>	<input type="radio"/>	<input type="radio"/>
PA48	TLN	Negative torque limit value	5000	0.1%	<input type="radio"/>	<input type="radio"/>	<input type="radio"/>	<input type="radio"/>

Speed control relevant parameters								
Parameter code	Abbreviation	Function of parameter	Default value	Unit	Control mode			
					Pt	Pr	S	T
PA01(*)	STY	Control mode setting	1000h	N/A	<input type="radio"/>	<input type="radio"/>	<input type="radio"/>	<input type="radio"/>
PA05	TL1	Internal torque limit 1	100	%	<input type="radio"/>	<input type="radio"/>	<input type="radio"/>	<input type="radio"/>
PA14(*)	ENR	Encoder output pulses	10000	pulse/rev	<input type="radio"/>	<input type="radio"/>	<input type="radio"/>	<input type="radio"/>
PB18	SFLT	Speed command low-pass filter smooth time constant	0	ms			<input type="radio"/>	<input type="radio"/>
PC05	SC1	Internal speed command 1	100	rpm			<input type="radio"/>	<input type="radio"/>
PC06	SC2	Internal speed command 2	500	rpm			<input type="radio"/>	<input type="radio"/>
PC07	SC3	Internal speed command 3	1000	rpm			<input type="radio"/>	<input type="radio"/>
PC08	SC4	Internal speed command 4	200	rpm			<input type="radio"/>	<input type="radio"/>
PC09	SC5	Internal speed command 5	300	rpm			<input type="radio"/>	<input type="radio"/>
PC10	SC6	Internal speed command 6	500	rpm			<input type="radio"/>	<input type="radio"/>
PC11	SC7	Internal speed command 7	800	rpm			<input type="radio"/>	<input type="radio"/>
PC25	TL2	Internal torque limit 2	100	%	<input type="radio"/>	<input type="radio"/>	<input type="radio"/>	<input type="radio"/>
PA47	TLP	Positive torque limit	5000	0.1%	<input type="radio"/>	<input type="radio"/>	<input type="radio"/>	<input type="radio"/>
PA48	TLN	Negative torque limit	5000	0.1%	<input type="radio"/>	<input type="radio"/>	<input type="radio"/>	<input type="radio"/>

Position control relevant parameters								
Parameter code	Abbreviation	Parameter function	Default value	Unit	Control mode			
					Pt	Pr	S	T
PA01(*)	STY	Control mode setting	1000h	N/A	○	○	○	○
PA04	HMOV	Homing mode	0000h	N/A		○		
PA05	TL1	Internal torque limit 1	100	%	○	○	○	○
PA06	CMX	Electronic gear numerator	1	N/A	○	○		
PA07 (▲)	CDV	Electronic gear denominator	1	N/A	○	○		
PA13 (*)	PLSS	Command pulse option	0000h	N/A	○			
PA14 (*)	ENR	Encoder output pulses	10000	Pulse/rev	○	○	○	○
PA39(*)	POL	Motor rotation direction option	0000h	N/A	○	○	○	○
PC25	TL2	Internal torque limit 2	100	%	○	○	○	○
PC32	CMX2	Electronic gear numerator 2	1	N/A	○			
PC33	CMX3	Electronic gear numerator 3	1	N/A	○			
PC34	CMX4	Electronic gear numerator 4	1	N/A	○			
PE01	ODEF	Definition of homing	00000000h	N/A		○		
PE02	ODAT	Origin offset value definition	0	N/A		○		
PE03~ PE98		Refer to section 8. 3 for PR related definition.			○	○		
PF01 ~PF87		Refer to section 8. 3 for PR related definition.			○	○		
PA47	TLP	Positive torque limit	5000	0.1%	○	○	○	○
PA48	TLN	Negative torque limit	5000	0.1%	○	○	○	○

Parameter code	Abbreviation	Parameter function	Default value	Unit	Control mode			
					Pt	Pr	S	T
PF89(*)	BLSF	Backlash compensation option	0	N/A	<input type="radio"/>	<input type="radio"/>		
PF90	BLSP	Backlash compensation setting(before E gears)	0	pulse	<input type="radio"/>	<input type="radio"/>		
PF91	BLST	Backlash compensation time constant setting	0	0.1ms	<input type="radio"/>	<input type="radio"/>		

Filter smoothing and resonance suppression relevant parameters								
Parameter code	Abbreviation	Parameter function	Default value	Unit	Control mode			
					Pt	Pr	S	T
PB01	NHF1	Frequency of Machine resonance suppression filter 1	1000	Hz	<input type="radio"/>	<input type="radio"/>	<input type="radio"/>	<input type="radio"/>
PB02	NHD1	Attenuation rate of machine resonance suppression filter 1	0	dB	<input type="radio"/>	<input type="radio"/>	<input type="radio"/>	<input type="radio"/>
PB03	NLP	Resonance suppression low-pass filter	17	0.1ms	<input type="radio"/>	<input type="radio"/>	<input type="radio"/>	<input type="radio"/>
PB04	PST	Position command filter time constant	3	ms	<input type="radio"/>	<input type="radio"/>		
PB19	TQC	Torque command filter time constant	0	ms				<input type="radio"/>
PB20	SJIT	Speed feedback filter time constant	0	0.1ms	<input type="radio"/>	<input type="radio"/>	<input type="radio"/>	<input type="radio"/>
PB21	NHF2	Frequency of machine resonance suppression filter 2	1000	Hz	<input type="radio"/>	<input type="radio"/>	<input type="radio"/>	<input type="radio"/>
PB22	NHD2	Attenuation of machine resonance suppression filter 2	0	dB	<input type="radio"/>	<input type="radio"/>	<input type="radio"/>	<input type="radio"/>
PB23(▲)	IGE	Current gain enhancement function	0	N/A	<input type="radio"/>	<input type="radio"/>	<input type="radio"/>	<input type="radio"/>
PB25	NHF3	Frequency of machine resonance suppression filter 3	1000	Hz	<input type="radio"/>	<input type="radio"/>	<input type="radio"/>	<input type="radio"/>
PB26	NHD3	Attenuation of machine resonance	0	dB	<input type="radio"/>	<input type="radio"/>	<input type="radio"/>	<input type="radio"/>

Parameter code	Abbreviation	Parameter function	Default value	Unit	Control mode			
					Pt	Pr	S	T
							suppression filter 3	
PB27	ANCF	Auto resonance suppression mode setting	0	N/A	○	○	○	○
PB28	ANCL	Auto resonance suppression detection level	50	%	○	○	○	○
PB29	AVSM	Auto low frequency vibration suppression mode	0	N/A	○	○		
PB30	VCL	Low-frequency vibration detection level setting	50	pulse	○	○		
PB31	VSF1	Low frequency vibration suppression frequency setting 1	100	0.1Hz	○	○		
PB32	VSG1	Low frequency vibration suppression gain 1	0	N/A	○	○		
PB33	VSF2	Low frequency vibration suppression frequency setting 2	100	0.1Hz	○	○		
PB34	VSG2	Low frequency vibration suppression gain 2	0	N/A	○	○		
PB35	FRCL	Friction compensation level	0	%	○	○	○	
PB36	FRCT	Friction compensation smoothing time constant	0	ms	○	○	○	
PB37	FRCM	Friction compensation mode option	0	N/A	○	○	○	
PB38	FFCT	Position feed forward filter time constant	0	ms	○	○		
PC01	STA	Acceleration time constant	200	ms		○	○	○
PC02	STB	Deceleration time constant	200	ms		○	○	○
PC03	STC	S-curve acceleration/deceleration time constant	0	ms		○	○	○
PD17(*)	DOP1	LSP, LSN stop mode option	0000h	N/A	○	○	○	
PB45	NHF4	Frequency of machine resonance suppression filter 4	1000	Hz	○	○	○	○
PB46	NHD4	Attenuation of machine resonance suppression filter 4	0	dB	○	○	○	○
PB47	NHF5	Frequency of machine resonance suppression filter 5	1000	Hz	○	○	○	○
PB48	NHD5	Attenuation of machine resonance	0	dB	○	○	○	○

Parameter code	Abbreviation	Parameter function	Default value	Unit	Control mode			
					Pt	Pr	S	T
PB50	MVF	Position command average filter time constant	0	ms	<input type="checkbox"/>	<input type="checkbox"/>	<input type="checkbox"/>	<input type="checkbox"/>
PC39	LPS	Low-pass filter setting option	0000h	N/A	<input type="checkbox"/>	<input type="checkbox"/>	<input type="checkbox"/>	<input type="checkbox"/>

Gain and switch relevant parameters								
Parameter code	Abbreviation	Parameter function	Default value	Unit	Control mode			
					Pt	Pr	S	T
PA02	ATUM	AUTO tuning mode setting	0002h	N/A	<input type="checkbox"/>	<input type="checkbox"/>	<input type="checkbox"/>	<input type="checkbox"/>
PA03	ATUL	Auto-tuning response level setting	0010	N/A	<input type="checkbox"/>	<input type="checkbox"/>	<input type="checkbox"/>	<input type="checkbox"/>
PB05	FFC	Position feed-forward gain	0	0.001	<input type="checkbox"/>	<input type="checkbox"/>	<input type="checkbox"/>	<input type="checkbox"/>
PB07	PG1	Position loop gain	45	rad/s	<input type="checkbox"/>	<input type="checkbox"/>	<input type="checkbox"/>	<input type="checkbox"/>
PB08	VG1	Speed loop gain	183	rad/s	<input type="checkbox"/>	<input type="checkbox"/>	<input type="checkbox"/>	<input type="checkbox"/>
PB09	VIC	Speed integral gain	34	ms	<input type="checkbox"/>	<input type="checkbox"/>	<input type="checkbox"/>	<input type="checkbox"/>
PB10	VFG	Speed feed-forward gain	0	0.0001	<input type="checkbox"/>	<input type="checkbox"/>	<input type="checkbox"/>	<input type="checkbox"/>
PB11(*)	CDP	Gain switch option	0000h	N/A	<input type="checkbox"/>	<input type="checkbox"/>	<input type="checkbox"/>	<input type="checkbox"/>
PB12	CDS	Gain switch condition	10	Kpps / Pulse / rpm	<input type="checkbox"/>	<input type="checkbox"/>	<input type="checkbox"/>	<input type="checkbox"/>
PB13	CDT	Gain switch time constant	1	ms	<input type="checkbox"/>	<input type="checkbox"/>	<input type="checkbox"/>	<input type="checkbox"/>
PB14	GD2	Servo motor load inertia ratio 2	70	0.1time	<input type="checkbox"/>	<input type="checkbox"/>	<input type="checkbox"/>	<input type="checkbox"/>
PB15	PG2	Position loop gain change ratio	100	%	<input type="checkbox"/>	<input type="checkbox"/>	<input type="checkbox"/>	<input type="checkbox"/>
PB16	VG2	Speed loop gain change ratio	100	%	<input type="checkbox"/>	<input type="checkbox"/>	<input type="checkbox"/>	<input type="checkbox"/>
PB17	VIC2	Speed integral gain change ratio	100	%	<input type="checkbox"/>	<input type="checkbox"/>	<input type="checkbox"/>	<input type="checkbox"/>
PB24	VDC	Speed differential compensation	980	N/A	<input type="checkbox"/>	<input type="checkbox"/>	<input type="checkbox"/>	<input type="checkbox"/>
PB44	PPD	Position loop compensation gain	0	rad/s	<input type="checkbox"/>	<input type="checkbox"/>	<input type="checkbox"/>	<input type="checkbox"/>
PB49	DOB	External interference	0	N/A	<input type="checkbox"/>	<input type="checkbox"/>	<input type="checkbox"/>	<input type="checkbox"/>

		compensation gain							
Digital I/O relevant parameters									
Parameter code	Abbreviation	Parameter function	Default value	Unit	Control mode				
					Pt	Pr	S	T	
PA12	INP	In-position range	1310	pulse	<input type="checkbox"/>	<input type="checkbox"/>	<input type="checkbox"/>	<input type="checkbox"/>	<input type="checkbox"/>
PC17	ZSP	Zero speed signal acknowledged range	50	rpm	<input type="checkbox"/>	<input type="checkbox"/>	<input type="checkbox"/>	<input type="checkbox"/>	<input type="checkbox"/>
PC16	MBR	Electromagnetic brake sequence output time	100	ms	<input type="checkbox"/>	<input type="checkbox"/>	<input type="checkbox"/>	<input type="checkbox"/>	<input type="checkbox"/>
PD01(*)	DIA1	Input signal automatic ON option 1	0000h	N/A	<input type="checkbox"/>	<input type="checkbox"/>	<input type="checkbox"/>	<input type="checkbox"/>	<input type="checkbox"/>
PD02(*)	DI1	Input signal option 1(pin CN1-14)	0001h	N/A	<input type="checkbox"/>	<input type="checkbox"/>	<input type="checkbox"/>	<input type="checkbox"/>	<input type="checkbox"/>
PD03(*)	DI2	Input signal option 2(pin CN1-15)	000Dh	N/A	<input type="checkbox"/>	<input type="checkbox"/>	<input type="checkbox"/>	<input type="checkbox"/>	<input type="checkbox"/>
PD04(*)	DI3	Input signal option 3(pin CN1-16)	0003h	N/A	<input type="checkbox"/>	<input type="checkbox"/>	<input type="checkbox"/>	<input type="checkbox"/>	<input type="checkbox"/>
PD05(*)	DI4	Input signal option 4(pin CN1-17)	0004h	N/A	<input type="checkbox"/>	<input type="checkbox"/>	<input type="checkbox"/>	<input type="checkbox"/>	<input type="checkbox"/>
PD06(*)	DI5	Input signal option 5(pin CN1-18)	0002h	N/A	<input type="checkbox"/>	<input type="checkbox"/>	<input type="checkbox"/>	<input type="checkbox"/>	<input type="checkbox"/>
PD07(*)	DI6	Input signal option 6(pin CN1-19)	000Fh	N/A	<input type="checkbox"/>	<input type="checkbox"/>	<input type="checkbox"/>	<input type="checkbox"/>	<input type="checkbox"/>
PD08(*)	DI7	Input signal option 7(pin CN1-20)	0012h	N/A	<input type="checkbox"/>	<input type="checkbox"/>	<input type="checkbox"/>	<input type="checkbox"/>	<input type="checkbox"/>
PD09(*)	DI8	Input signal option 8(pin CN1-21)	0019h	N/A	<input type="checkbox"/>	<input type="checkbox"/>	<input type="checkbox"/>	<input type="checkbox"/>	<input type="checkbox"/>
PD10(*)	DO1	Output signal option 1(pin CN1-41)	0003h	N/A	<input type="checkbox"/>	<input type="checkbox"/>	<input type="checkbox"/>	<input type="checkbox"/>	<input type="checkbox"/>
PD11(*)	DO2	Output signal option 2(pin CN1-42)	0008h	N/A	<input type="checkbox"/>	<input type="checkbox"/>	<input type="checkbox"/>	<input type="checkbox"/>	<input type="checkbox"/>
PD12(*)	DO3	Output signal option 3(pin CN1-43)	0002h	N/A	<input type="checkbox"/>	<input type="checkbox"/>	<input type="checkbox"/>	<input type="checkbox"/>	<input type="checkbox"/>
PD13(*)	DO4	Output signal option 4(pin CN1-44)	0005h	N/A	<input type="checkbox"/>	<input type="checkbox"/>	<input type="checkbox"/>	<input type="checkbox"/>	<input type="checkbox"/>
PD14(*)	DO5	Output signal option 5(pin CN1-45)	0001h	N/A	<input type="checkbox"/>	<input type="checkbox"/>	<input type="checkbox"/>	<input type="checkbox"/>	<input type="checkbox"/>
PD15(*)	DIF	Digital input filter setting	2	N/A	<input type="checkbox"/>	<input type="checkbox"/>	<input type="checkbox"/>	<input type="checkbox"/>	<input type="checkbox"/>
PD16(*)	IOS	Digital input control source option	0000h	N/A	<input type="checkbox"/>	<input type="checkbox"/>	<input type="checkbox"/>	<input type="checkbox"/>	<input type="checkbox"/>
PD17(*)	DOP1	LSP, LSN stop mode option	0000h	N/A	<input type="checkbox"/>	<input type="checkbox"/>	<input type="checkbox"/>	<input type="checkbox"/>	<input type="checkbox"/>
PD18(*)	DOP2	CR signal clear setting	0000h	N/A	<input type="checkbox"/>	<input type="checkbox"/>	<input type="checkbox"/>	<input type="checkbox"/>	<input type="checkbox"/>
PD19(*)	DOP3	Alarm code output option	0000h	N/A	<input type="checkbox"/>	<input type="checkbox"/>	<input type="checkbox"/>	<input type="checkbox"/>	<input type="checkbox"/>
PD20(*)	DOP4	Operation option when the alarm reset signal is short-circuited	0000h	N/A	<input type="checkbox"/>	<input type="checkbox"/>	<input type="checkbox"/>	<input type="checkbox"/>	<input type="checkbox"/>
PD21(*)	DI9	Input signal option 9	0018h	N/A	<input type="checkbox"/>	<input type="checkbox"/>	<input type="checkbox"/>	<input type="checkbox"/>	<input type="checkbox"/>
PD25(■)	ITST	Communication control digital input status	0000h	N/A	<input type="checkbox"/>	<input type="checkbox"/>	<input type="checkbox"/>	<input type="checkbox"/>	<input type="checkbox"/>
PD27(*)	DOD	Definition of output signal contact	0004h	N/A	<input type="checkbox"/>	<input type="checkbox"/>	<input type="checkbox"/>	<input type="checkbox"/>	<input type="checkbox"/>
PD29	DID	Software DI A/B contact setting	0000h	N/A	<input type="checkbox"/>	<input type="checkbox"/>	<input type="checkbox"/>	<input type="checkbox"/>	<input type="checkbox"/>
PD33	SFDO	Software DO register	0000h	N/A	<input type="checkbox"/>	<input type="checkbox"/>	<input type="checkbox"/>	<input type="checkbox"/>	<input type="checkbox"/>

Communication relevant parameters								
Parameter code	Abbreviation	Parameter function	Default value	Unit	Control mode			
					Pt	Pr	S	T
PC20(*)	SNO	Servo drive communication device number	1	N/A	○	○	○	○
PC21(*)	CMS	Communication mode option	0	N/A	○	○	○	○
PC22(*)	BPS	Communication protocol option	0010h	N/A	○	○	○	○
PC23	SIC	Serial communication timeout option	0	s	○	○	○	○
PA23(■)	MCS	Memory write-inhibit function	0	N/A	○	○	○	○
PC41 ~PC60		Communication mapping relevant parameters						

Other parameters								
Parameter code	Abbreviation	Parameter function	Default value	Unit	Control mode			
					Pt	Pr	S	T
PA40(▲)	SPW	Special parameter write option	0000h	N/A	○	○	○	○
PA42(*)	BLK	Parameter write-inhibit	0000h	N/A	○	○	○	○
PB06	GD1	Servo motor Load inertia ratio	70	0.1time	○	○	○	
PB14	GD2	Servo motor load inertia ratio 2	70	0. time	○	○	○	
PC18(*)	COP1	Stop option and power interruption and restart option	0010h	N/A	○	○	○	○
PC19(*)	COP2	Alarm record clear option	0000h	N/A	○	○	○	○
PD20(*)	DOP4	Operation option when the alarm reset signal is short-circuited	0000h	N/A	○	○	○	○

8.3 Parameter group introduction

No	Abbr.	Parameter function and description	mode	Default	Range	Unit				
PA01	STY (*)	<p>Control mode setting</p> <table border="1" style="margin-left: 20px;"> <tr> <td style="width: 20px; height: 20px; text-align: center;">u</td> <td style="width: 20px; height: 20px; text-align: center;">z</td> <td style="width: 20px; height: 20px; text-align: center;">y</td> <td style="width: 20px; height: 20px; text-align: center;">x</td> </tr> </table> <p><u>x:Control mode select</u> x=0:position mode x=1:position and speed dual mode x=2:speed mode x=3:speed and torque dual mode x=4:torque mode x=5:torque and position dual mode</p> <p><u>y: Position control command input options</u> y=0: external pulse input y=1: Internal register input y=2: Pt-Pr position dual mode</p> <p><u>z: Electromagnetic brake function enable option</u> This function is a digital output function, it can be defined by PD10~PD14. It's valid only when using on a servo with electromagnetic brake. z=0:without electromagnetic brake function z=1:enable electromagnetic brake function</p> <p><u>u:DI,DO setting value control</u> u=0: the value of DI, DO(PD02 ~ PD14, PD21) are fixed during mode switching,and DI, DO can be defined by user. u=1: The value of DI, DO(PD02 ~ PD14, PD21) are varied with different control modes during mode switching,and DI, DO cannot be defined by the user.</p>	u	z	y	x	All	1000h	0000h ~ 1125h	N/A
u	z	y	x							

PA02	ATUM	Auto tuning mode setting:	All	0002h	0000h	N/A				
	(▲)	<table border="1" style="display: inline-table; border-collapse: collapse;"> <tr> <td style="padding: 2px 5px;">0</td> <td style="padding: 2px 5px;">0</td> <td style="padding: 2px 5px;">0</td> <td style="padding: 2px 5px;">x</td> </tr> </table>	0	0	0	x			~ 0005h	
0	0	0	x							
		<p><u>x: Auto gain tuning mode setting</u></p> <p>x=0~1:manual gain tuning mode(PI control)</p> <p>x=2:Auto gain tuning mode 1(keep tuning load inertia ratio and bandwidth)</p> <p>x=3:Auto gain tuning mode 2(fixed load inertia ratio, tuning bandwidth)</p> <p>x=4:Interpolation mode (fixed position loop gain(PB07), and auto tuning the remaining gain)</p> <p>x=5:Interpolation mode 2(fixed PB06 and PB07, and auto tuning the remaining gain)</p>								

No	Abbr.	Parameter function and description	mode	Default	Range	Unit																																																																							
PA03	ATUL	Auto tuning response level setting	All	10	1~32	N/A																																																																							
<u>Auto tuning mode response setting</u>																																																																													
		<table border="1"> <thead> <tr> <th>Response setting</th> <th>Response</th> <th>Speed loop response frequency</th> </tr> </thead> <tbody> <tr><td>1</td><td rowspan="11">Low response</td><td>10.0 Hz</td></tr> <tr><td>2</td><td>11.3 Hz</td></tr> <tr><td>3</td><td>12.7 Hz</td></tr> <tr><td>4</td><td>14.3 Hz</td></tr> <tr><td>5</td><td>16.1 Hz</td></tr> <tr><td>6</td><td>18.1 Hz</td></tr> <tr><td>7</td><td>20.4 Hz</td></tr> <tr><td>8</td><td>23.0 Hz</td></tr> <tr><td>9</td><td>25.9 Hz</td></tr> <tr><td>10</td><td>29.2 Hz</td></tr> <tr><td>11</td><td>32.9 Hz</td></tr> <tr><td>12</td><td rowspan="5">Middle response</td><td>37.0 Hz</td></tr> <tr><td>13</td><td>41.7 Hz</td></tr> <tr><td>14</td><td>47.0 Hz</td></tr> <tr><td>15</td><td>52.9 Hz</td></tr> <tr><td>16</td><td>59.6 Hz</td></tr> </tbody> </table>	Response setting	Response	Speed loop response frequency	1	Low response	10.0 Hz	2	11.3 Hz	3	12.7 Hz	4	14.3 Hz	5	16.1 Hz	6	18.1 Hz	7	20.4 Hz	8	23.0 Hz	9	25.9 Hz	10	29.2 Hz	11	32.9 Hz	12	Middle response	37.0 Hz	13	41.7 Hz	14	47.0 Hz	15	52.9 Hz	16	59.6 Hz	<table border="1"> <thead> <tr> <th>Response setting</th> <th>Response</th> <th>Speed loop response frequency</th> </tr> </thead> <tbody> <tr><td>17</td><td rowspan="11">Middle response</td><td>67.1</td></tr> <tr><td>18</td><td>75.6</td></tr> <tr><td>19</td><td>85.2</td></tr> <tr><td>20</td><td>95.9</td></tr> <tr><td>21</td><td>108.0</td></tr> <tr><td>22</td><td>121.7</td></tr> <tr><td>23</td><td>137.1</td></tr> <tr><td>24</td><td>154.4</td></tr> <tr><td>25</td><td>173.9</td></tr> <tr><td>26</td><td>195.9</td></tr> <tr><td>27</td><td>220.6</td></tr> <tr><td>28</td><td rowspan="5">High response</td><td>248.5</td></tr> <tr><td>29</td><td>279.9</td></tr> <tr><td>30</td><td>315.3</td></tr> <tr><td>31</td><td>355.1</td></tr> <tr><td>32</td><td>400.0</td></tr> </tbody> </table>	Response setting	Response	Speed loop response frequency	17	Middle response	67.1	18	75.6	19	85.2	20	95.9	21	108.0	22	121.7	23	137.1	24	154.4	25	173.9	26	195.9	27	220.6	28	High response	248.5	29	279.9	30	315.3	31	355.1	32	400.0
Response setting	Response	Speed loop response frequency																																																																											
1	Low response	10.0 Hz																																																																											
2		11.3 Hz																																																																											
3		12.7 Hz																																																																											
4		14.3 Hz																																																																											
5		16.1 Hz																																																																											
6		18.1 Hz																																																																											
7		20.4 Hz																																																																											
8		23.0 Hz																																																																											
9		25.9 Hz																																																																											
10		29.2 Hz																																																																											
11		32.9 Hz																																																																											
12	Middle response	37.0 Hz																																																																											
13		41.7 Hz																																																																											
14		47.0 Hz																																																																											
15		52.9 Hz																																																																											
16		59.6 Hz																																																																											
Response setting	Response	Speed loop response frequency																																																																											
17	Middle response	67.1																																																																											
18		75.6																																																																											
19		85.2																																																																											
20		95.9																																																																											
21		108.0																																																																											
22		121.7																																																																											
23		137.1																																																																											
24		154.4																																																																											
25		173.9																																																																											
26		195.9																																																																											
27		220.6																																																																											
28	High response	248.5																																																																											
29		279.9																																																																											
30		315.3																																																																											
31		355.1																																																																											
32		400.0																																																																											

PA04	HMOV	Homing mode				Pr	0000h	0000h ~ 0128h	N/A		
		0	z	y	x						
		z		y						x	
		Limit setting		Z signal setting						Homing methods	
		0~1		0~2						0~8	
		When reaching the limits: Z = 0: show error, Z = 1: reverse direction		y = 0: return to last Z pulse y = 1: go forward to next Z pulse						x = 0: homing in forward direction and define LSP as homing origin	
				y = 2: do not look for Z pulse						x = 1: homing in reverse direction and define LSN as homing origin	
										x = 2: homing in forward direction ORGP: OFF→ON as homing origin	
										x = 3: homing in reverse direction, ORGP: OFF→ON as homing origin	
										x = 4: look for Z pulse in forward direction and define it as homing origin	
x = 5: look for Z pulse in reverse direction and define it as homing origin											
		y = 0: return to last Z pulse y = 1: go forward to next Z pulse		x = 6: homing in forward direction, ORGP: ON→OFF as homing origin							
		y = 2: do not look for Z pulse		x = 7: homing in reverse direction, ORGP: ON→OFF as homing origin							
				x = 8: define current position as the origin							

PA05	TL1	<p>Internal torque limit value 1</p> <p>The parameter can limit the torque generated by the servo motor. The unit of parameter setting value is in percentage (%). The calculation is as follows:</p> <p><u>Torque limit value=maximum torque*the setting value</u></p> <p><u>if TL1-SG is short-circuited , the option of torque limit is as follows:</u></p> <table border="1"> <tr> <td>TL1-SG</td> <td>Torque limit</td> </tr> <tr> <td>Open</td> <td>PA05</td> </tr> <tr> <td>Short</td> <td> <p>If PC25<PA05, the torque limit=PC25</p> <p>If PC25>PA05,the torque limit=PA05.</p> </td> </tr> </table>	TL1-SG	Torque limit	Open	PA05	Short	<p>If PC25<PA05, the torque limit=PC25</p> <p>If PC25>PA05,the torque limit=PA05.</p>	All	100	0 ~ 100	%
TL1-SG	Torque limit											
Open	PA05											
Short	<p>If PC25<PA05, the torque limit=PC25</p> <p>If PC25>PA05,the torque limit=PA05.</p>											
No	Abbr.	Parameter function and description	mode	Default	Range	Unit						
PA06	CMX	<p>Electronic gear numerator</p> <p>Note: when SV is ON in Pr mode, this parameter cannot be set.</p>	Pr. Pt	1	1 ~ 2 ²⁶	N/A						
PA07	CDV	<p>Electronic gear denominator</p> <p>(▲) The incorrect setting will cause unexpected fast rotation. Ensure to do the setting when SERVO is OFF.</p> <p>Command pulse input ratio setting</p> <div style="text-align: center;"> <p>command pulse input f_1 → $\frac{CMX}{CDV}$ → position command $f_2 = f_1 \cdot \frac{CMX}{CDV}$</p> </div> <p>Note: limitation: $1/50 < (CMX/CDV) < 64000$</p>	Pr. Pt	1	1 ~ 2 ²⁶	N/A						

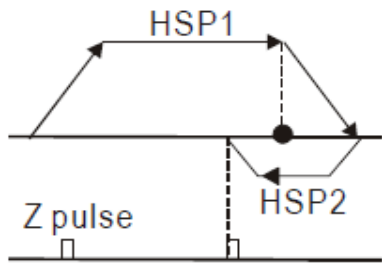
PA08	HSPD 1	Homing high speed option 1 	Pr	100	1 ~ 2000	rpm								
PA09	HSPD 2	Homing high speed option 2	Pr	20	1 ~ 500	rpm								
No	Abbr.	Parameter function and description	mode	Default	Range	Unit								
PA10	RES1	Regenerative resistor value <table border="1" data-bbox="411 974 1018 1258"> <thead> <tr> <th>Model</th> <th>Default value</th> </tr> </thead> <tbody> <tr> <td>below 500W</td> <td>100Ω</td> </tr> <tr> <td>750W~1KW</td> <td>40Ω</td> </tr> <tr> <td>1. 5KW~3KW</td> <td>13Ω</td> </tr> </tbody> </table>	Model	Default value	below 500W	100Ω	750W~1KW	40Ω	1. 5KW~3KW	13Ω	All	Note *	10 ~ 750	Oh m
Model	Default value													
below 500W	100Ω													
750W~1KW	40Ω													
1. 5KW~3KW	13Ω													
PA11	RES2	Capacity of regenerative resistor. <table border="1" data-bbox="411 1332 1018 1617"> <thead> <tr> <th>Model</th> <th>Default value</th> </tr> </thead> <tbody> <tr> <td>below 500W.</td> <td>20W</td> </tr> <tr> <td>750W~1KW</td> <td>40W</td> </tr> <tr> <td>1. 5KW~3KW</td> <td>100W</td> </tr> </tbody> </table> Refer to section 14. 2 for external resistor capacity.	Model	Default value	below 500W.	20W	750W~1KW	40W	1. 5KW~3KW	100W	All	Note *	0 ~ 3000	Watt
Model	Default value													
below 500W.	20W													
750W~1KW	40W													
1. 5KW~3KW	100W													
PA12	INP	In-position range:In the position control mode, when the deviation between the position command and the actual motor position is less than the set value of INP, the INP signal of DO will output. The default value for 17bit encoder is 1310	Pt. Pr	1310 or 41943	0 ~ 2 ²²	puls e								

No	Abbr.	Parameter function and description	mode	Default	Range	Unit																												
PA13	PLSS	<p>Pulse command option</p> <p>(*) Select the type of external input pulse train.</p> <table border="1" style="margin-left: 20px;"> <tr> <td style="width: 20px; height: 20px; text-align: center;">0</td> <td style="width: 20px; height: 20px; text-align: center;">z</td> <td style="width: 20px; height: 20px; text-align: center;">y</td> <td style="width: 20px; height: 20px; text-align: center;">x</td> </tr> </table> <p><u>x: Input pulse train format select</u> x=0:forward/reverse rotation pulse train x=1: pulse train+sign x=2: AB phase pulse train.</p> <p><u>y: Input pulse train logic select</u> y=0:positive logic,y=1:negative logic</p> <table border="1" style="margin-left: 20px;"> <thead> <tr> <th colspan="2">pulse logic and form</th> <th>Forward</th> <th>Reverse</th> </tr> </thead> <tbody> <tr> <td rowspan="3" style="writing-mode: vertical-rl; transform: rotate(180deg);">Negative logic</td> <td>A/B phase pulse train</td> <td>PP </td> <td>PP </td> </tr> <tr> <td>Pulse train + sign</td> <td>PP </td> <td>PP </td> </tr> <tr> <td>Forward/reverse rotation pulse train</td> <td>PP </td> <td>PP </td> </tr> <tr> <td rowspan="3" style="writing-mode: vertical-rl; transform: rotate(180deg);">Positive logic</td> <td>A/B phase pulse train</td> <td>PP </td> <td>PP </td> </tr> <tr> <td>Pulse train + sign</td> <td>PP </td> <td>PP </td> </tr> <tr> <td>Forward/reverse rotation pulse train</td> <td>PP </td> <td>PP </td> </tr> </tbody> </table> <p><u>z: The setting of input pulse filter.</u> z=0:the maximum input pulse frequency is 500kpps. (applicable frequency is between 200kpps-500kpps) z=1: the maximum input pulse frequency is 200kpps. (applicable frequency is below 200kpps) z=2:the maximum input pulse frequency is 2Mpps. (applicable frequency is between 500kpps ~2Mpps) z=3:the maximum input pulse frequency is 4Mpps. (applicable frequency is between 2MPPS~4MPPS)</p>	0	z	y	x	pulse logic and form		Forward	Reverse	Negative logic	A/B phase pulse train	PP	PP	Pulse train + sign	PP	PP	Forward/reverse rotation pulse train	PP	PP	Positive logic	A/B phase pulse train	PP	PP	Pulse train + sign	PP	PP	Forward/reverse rotation pulse train	PP	PP	Pt	0000h	0000h ~ 0312h	N/A
0	z	y	x																															
pulse logic and form		Forward	Reverse																															
Negative logic	A/B phase pulse train	PP	PP																															
	Pulse train + sign	PP	PP																															
	Forward/reverse rotation pulse train	PP	PP																															
Positive logic	A/B phase pulse train	PP	PP																															
	Pulse train + sign	PP	PP																															
	Forward/reverse rotation pulse train	PP	PP																															













No	Abbr.	Parameter function and description	mode	Default	Range	Unit
PA14	ENR	<p>Encoder output pulses</p> <p>(*) Set the pulse number of the drive output encoder (A phase, B phase). The number of output pulses is varied according to PA39 encoder pulse output setting.</p> <p>Put the setting value 4 times greater than the frequency output of phase A and phase B. In fact, the single-phase output pulse of phase A and phase B is 1/4 of the set value. The highest output frequency is 20MHZ (after 4 times the frequency), and it should not exceed this limit.</p> <p>When doing the output pulse setting, its wave number is as follows: PA39 is set to □□□□(default value), and the setting value is the number of pulses output in one revolution.</p> <p><u>For example: Assuming that PA39 is set to 0000h and PA14 is set to 1024, the number of pulses output in one revolution is 1024 (pulse/rev)</u></p> <p>For output division ratio setting, the output pulse is as follows: Use the number of output pulses in one revolution divided by the set value of PA14</p> $\text{Output pulses} = \frac{\text{Number of pulse per revolution}}{\text{PA14 setting value}}$ <p><u>For example:</u></p> <p>If PA39 is set to 0100h and PA14 is set to 512, the output pulse number per revolution is $2^{17} / 16 = 8192$(pulse/rev)</p>	All	10000	4 ~ 2^{22}	Pulse/rev

No	Abbr.	Parameter function and description	mode	Default	Range	Unit
PA15	CRSH A	Motor crash protect level(torque percentage) To set protection level(for the rated torque percentage, 0=turn off , the other setting value will enable the function.)	All	250	0~300	%
PA16	CRSH T	Motor crash protect level (protection time) To set protection time. When the setting level is reached and the setting protection time has taken, the AL.20 will occur.	All	500	0 ~ 1000	ms
PA17	OVL	Output overload DO warning level When the setting value is 0 - 100 and the servo motor continuously output reaches this level, the warning signal is activated. PS: If the setting value is over 100, this function is disabled.	All	120	0 ~ 120	%
PA18	OVS	Over speed protection level When the feedback speed exceeds this value, AL.06 will occur.	All	6300	1 ~ 6500	rpm
PA19	OVPE	Position deviation excess output level when the position deviation exceeds this set value, AL.08 will occur. The default value for 17bit encoder is 3×2^{17}	Pr. Pt	3×2^{17} or 3×2^{22}	1 $2^{31}-1$	puls e
PA20	OVPL 1 (*)	Position pulse frequency excess level 1 When input position pulse frequency exceeds this set value, AL.07 will occur.	Pt	4500	100 ~ 5000	KHz
PA21		Reserved.				

No	Abbr.	Parameter function and description	mode	Default	Range	Unit
PA22	DBF	Dynamic brake control function (*) The setting of Dynamic brake when alarm occurs. 0 : dynamic brake is enabled and motor stops immediately. 1 : dynamic brake is disabled and motor free run to stop.	All	0	0~1	N/A
PA23	MCS	Memory write-inhibit function (■) PA23 = 0 (all parameters can be written to EEPROM, including PA23) PA23 = 1 (all parameters will not be written to EEPROM, note: this parameter will be automatically set to 0 after power off and restart) PA23 = 2 (All parameters will not be written to EEPROM, but PA23 can be written to EEPROM. Note: After the parameter is powered off and restarted, the parameter remains at 2) Cautions: 1. When using communication control to write parameters, please set PA23=2 to prevent the EEPROM life from being reduced due to continuous writing of communication.	All	0	0~2	N/A
PA24 ~ PA27		Reserved				

























PA28	ABS	<p>Absolute encoder setting.</p> <p>(*) 0: incremental encoder, and the absolute motor can be operated as an incremental motor.</p> <p>1: absolute encoder(only applicable to absolute motors, if incremental motors are used, AL.24 will occur)</p>	All	0000h	0000h ~ 0001h	N/A
PA29	CAP	<p>Absolute homing position</p> <p>(■) This parameter set to 1 to clear the current absolute position of the encoder. The clearing function is the same as using ABSC to clear the coordinate.</p>	All	0000h	0000h ~ 0001h	N/A
PA30	UAP	<p>Update encoder absolute position</p> <p>(■) When PA30=1, update the data to PA31~PA33, and the position error is not cleared.</p> <p>When PA30=2, update the data to PA31~PA33 and clear the position error, When this command is enabled, the motor's current position is set as the target position.</p>	All	0	0 ~ 2	N/A
PA31	APST	<p>Absolute coordinate system status (Read only)</p> <p>Bit0: 1 means the absolute position is lost, 0 means normal.</p> <p>Bit1: 1 means low battery voltage, 0 means normal.</p> <p>Bit2: 1 means the absolute number of revolution is overflowing, 0 means normal</p> <p>Bit3: Reserved (0)</p> <p>Bit4: 1 means the absolute coordinate has not been set. 0 means normal.</p> <p>Bit5 ~ Bit15: Reserved (0)</p>	All	0	0000h ~ 001Fh	N/A
PA32	APR	<p>Encoder absolute position (pulse number per revolution) (read only)</p> <p>The parameter displays the feedback pulse number of the absolute encoder position, and it is valid in absolute system(PA28=1).</p>	All	0	Pulse number per revolution	pulse

PA33	APP	Encoder absolute position (number of revolution) (read only) The parameter displays the number of revolution in absolute encoder system, and it is valid in absolute system(PA28=1)	All	0	32767 ~ -32768	Rev
PA34	ABSM	I/O communication of absolute system (*) When PA34=0, it indicates current using Delta absolute IO communication function When PA34=1, it indicates current using Mitsubishi absolute IO communication function.	All	0	0 ~ 1	N/A

No	Abbr	Parameter function and description	mode	Default	Range	Unit													
PA35	FNO1 (*)	<p>Function option 1</p> <table border="1" data-bbox="395 376 587 450"> <tr> <td>u</td> <td>z</td> <td>y</td> <td>x</td> </tr> </table> <p>x: Set torque and motor rotary direction</p> <table border="1" data-bbox="405 539 817 775"> <tr> <td></td> <td style="text-align: center;">0</td> <td style="text-align: center;">1</td> </tr> <tr> <td style="text-align: center;">Forward</td> <td></td> <td></td> </tr> <tr> <td style="text-align: center;">Reverse</td> <td></td> <td></td> </tr> </table> <p>In absolute system, when the value of PA35. x is changed, homing must be performed after restart the servo.</p> <p>y: Rotary direction definition</p> <p>y=0:the motor runs forwardly when ST1 is ON. The motor runs reversely when ST2 is ON.</p> <p>y=1:The motor runs forwardly when ST1 is OFF. The motor runs reversely when ST1 is ON and ST2 is invalid. The motor shaft is rotatable.</p> <p>y=2:The motor runs reversely when ST1 is OFF. The motor runs forwardly when ST1 is ON and ST2 is invalid. The motor shaft is rotatable.</p> <p>z: Option of servo lock</p> <p>z=0: Servo lock is valid and hold the stop position.</p> <p>z=1: Servo lock is invalid, the stop position is mobile. The drive will hold the rotation speed as 0 rpm.</p> <p>u:Judgement condition when control mode is switched.</p> <p>u=0:Judge ZSP signal when control mode is switched.</p> <p>u=1:Do not judge ZSP signal when control mode is switched.</p>	u	z	y	x		0	1	Forward			Reverse			All	0000h	0000h ~ 1121h	N/A
u	z	y	x																
	0	1																	
Forward																			
Reverse																			

PA36	FNO2 (*)	Function option 2(reserved for factory test only)	All	0000h	0000h ~ FFFFh	N/A
PA37	FNO3 (*)	Function option 3(reserved for factory test only)		0000h		

No	Abbr.	Parameter function and description	mode	Default	Range	Unit				
PA38	AOP3	<p>One-touch tuning function option.</p> <table border="1" style="margin-left: 40px;"> <tr> <td>0</td> <td>z</td> <td>y</td> <td>x</td> </tr> </table> <p>x:Auto gain tuning function x=0:Disable auto gain tuning function. x=1:Enable auto gain tuning function. y:Automatic high-frequency resonance suppression function y=0:Disable automatic high-frequency resonance suppression y=1:Enable automatic high-frequency resonance suppression z:Auto low-frequency swing arm suppression function z=0:Disable auto low-frequency swing arm suppression function z=1:Enable auto low-frequency swing arm suppression function</p> <p>Note 1: x=1 is necessary condition to enable one touch tuning function before you can choose high-frequency or low-frequency suppression function</p> <p>Note 2: When y=1 and one-touch tuning is complete, you must set PB27 to 0.</p> <p>Note 3: When z=1 and one-touch tuning is complete, you must set PB29 to 0.</p>	0	z	y	x	Pr. Pt S	0000h	0000h ~ 0111h	N/A
0	z	y	x							

No	Abbr.	Parameter function and description	mode	Default	Range	Unit																								
PA39	POL	<p>Motor rotation direction option</p> <p>(*) The relation among motor rotation direction ,input command pulse-train direction and encoder output pulse direction</p> <table border="1" style="margin-left: 20px;"> <tr> <td>0</td> <td>z</td> <td>y</td> <td>x</td> </tr> </table> <p><u>x: The input pulse command and motor rotation direction option</u></p> <table border="1" style="margin-left: 20px;"> <tr> <th rowspan="2">Setting value</th> <th colspan="2">Rotation direction of servo motor</th> </tr> <tr> <th>Forward pulse train input</th> <th>Reverse pulse train input</th> </tr> <tr> <td>0</td> <td>CCW</td> <td>CW</td> </tr> <tr> <td>1</td> <td>CW</td> <td>CCW</td> </tr> </table> <p><u>y:The motor rotation direction and encoder output pulse option</u></p> <table border="1" style="margin-left: 20px;"> <tr> <th>y</th> <th>motor CCW rotation</th> <th>motor CW rotation</th> </tr> <tr> <td>0</td> <td> A-phase  B-phase  </td> <td> A-phase  B-phase  </td> </tr> <tr> <td>1</td> <td> A-phase  B-phase  </td> <td> A-phase  B-phase  </td> </tr> </table> <p><u>z: Encoder output pulse setting option</u></p> <p>z=0: Output pulse setting</p> <p>z=1: Output division ratio setting</p> <p>This parameter is related with PA14.</p>	0	z	y	x	Setting value	Rotation direction of servo motor		Forward pulse train input	Reverse pulse train input	0	CCW	CW	1	CW	CCW	y	motor CCW rotation	motor CW rotation	0	A-phase  B-phase 	A-phase  B-phase 	1	A-phase  B-phase 	A-phase  B-phase 	<p>Pt</p> <p>All</p> <p>All</p>	0000h	0000h ~ 0111h	N/A
0	z	y	x																											
Setting value	Rotation direction of servo motor																													
	Forward pulse train input	Reverse pulse train input																												
0	CCW	CW																												
1	CW	CCW																												
y	motor CCW rotation	motor CW rotation																												
0	A-phase  B-phase 	A-phase  B-phase 																												
1	A-phase  B-phase 	A-phase  B-phase 																												

No	Abbr.	Parameter function and description	mode	Default	Range	Unit
PA40	SPW (▲)	Special parameter write option When the parameter is set to 0x0088, the factory default value will be restored after about 3 seconds, The servo can be operated only after restart the power.	All	0000h	0000h ~ 00FFh	N/A
PA41	POSPD	The maximum rotation speed setting of encoder The user sets the actual maximum speed which is achievable according to the application of the motor. If the speed exceed the setting, AL.30 occurs. When PA41 set to 0, it indicate this function is disabled.	All	6300	0 ~ 6500	rpm

No	Abbr.	Parameter function and description	mode	Default	Range	Unit						
PA42	BLK (*)	Parameter write-inhibit setting					All	0000h	0000h ~ 00FFh	N/A		
		value	PA group	PB group	PC group	PD group					PE group	PF group
		0000 default value	(readable and writable)									
		0001	(readable and writable)								unreadable and not writable	
		0002	(readable and writable)			unreadable and not writable						
		0003	(readable and writable)		unreadable and not writable							
		0004	(readable and writable)	unreadable and not writable								
		0005	(readable and writable)	unreadable and not writable								
		0006	Only PA42 is readable, the others is unreadable and not writable									
		Note: the parameter which is unreadable and not writable, it means the group is hidden on the panel.										
PA43	ENT(*)	Encoder type(This is an internal read-only parameter)	All	0								
No	Abbr.	Parameter function and description	mode	Default	Range	Unit						

PA44	EGM	<p>Electronic gear ratio option</p> <p>(*) PA44 = 0:use E-gear ratio as default value(PA06/PA07).</p> <p>PA44 = 1:E-gear ratio conversion is 1,(use position command pulse number setting per revolution (PA45)).</p> <p>FBP is PA45 setting value and Pt is pulse number per revolution.</p>	Pr. Pt	0	0 ~ 1	N/A
PA45	FBP	<p>Position command pulse setting per turn</p> <p>(▲) When PA44 = 1, this parameter can set the position command pulse per revolution.</p>	Pr. Pt	10000	500 ~ 10 ⁶	pulse
PA46	ATST	One-touch tuning operation(Reserved for factory test only)	Pr. Pt S	0000h	0000h ~ FF21h	N/A
PA47	TLP	<p>Positive torque limit</p> <p>The parameter is to limit the torque generated during forward rotation. The unit of setting value is 0. 1%. The calculation is as follows</p> $\text{Positive torque limit} = \frac{\text{motor max current}}{\text{motor rated current}} * \frac{PA47}{30}$	All	5000	0 ~ 32700	0.1%
PA48	TLN	<p>Negative torque limit</p> <p>The parameter is to limit the torque generated during reverse rotation. The unit of setting value is 0. 1%. The calculation is as follows</p> $\text{Negative torque limit} = \frac{\text{motor max current}}{\text{motor rated current}} * \frac{PA48}{30}$	All	5000	0 ~ 32700	0.1%

No	Abbr.	Parameter function and description	mode	Default	Range	Unit
PB01	NHF1	<p>Frequency of machine resonance suppression filter 1</p> <p>This parameter is to set the frequency of machine resonance suppression filter 1. The schematic diagram is as follows:</p>	All	1000	10 ~ 4000	Hz
PB02	NHD1	<p>Attenuation of machine resonance suppression filter 1</p> <p>This parameter is to set attenuation rate of machine resonance suppression and it should use together with NHF1.</p> <p>0:turn off the Notch filter function.</p>	All	0	0 ~ 32	dB
PB03	NLP	<p>Resonance suppression low-pass filter</p> <p>This parameter is to set the time constant of resonance suppression low-pass filter.</p>	All	17	0 ~ 10000	0. 1ms
PB04	PST	<p>Position command filter time constant</p> <p>This parameter is to set the time constant of position command. With an appropriate setting, the motor can run smoothly when the servo drive encounters a sudden change of position command.</p>	Pt. Pr	3	0 ~ 20000	ms

		<p>target position</p> <p>The actual time to reach the target position is 5 times of PST.</p>				
PB05	FFC	<p>Position feed-forward gain</p> <p>If the system runs smoothly in position mode, increasing the feed forward gain value will reduce the position tracking errors. If the system has resonated in position mode, decreasing the gain value will reduce mechanical vibration.</p>	Pt. Pr	0	0 ~ 200	%
PB06	GD1	<p>Servo motor Load inertia ratio</p> <p>This parameter is to set ratio value of load inertia to servo motor inertia. When select auto gain tuning mode(PA02) to 1 , PB06 will be set automatically .</p>	All	70	0 ~ 1200	0.1 time
PB07	PG1	<p>Position loop gain</p> <p>Increasing the position control gain can improve the traceability to position response and reduce the position errors. But too large setting value may cause vibration and noise. When auto gain tuning mode is used, the parameter will be automatically set.</p>	Pt. Pr	45	4 ~ 1024	rad/s
PB08	VG1	<p>Speed loop gain</p> <p>Increasing the speed control gain can improve the response speed, But too large setting value may cause vibration and noise. When auto gain tuning mode is used, the parameter will be automatically set.</p>	Pt. Pr S	183	40 ~ 9000	rad/s

PB09	VIC	Speed integral gain this parameter is time constant of speed loop integral.	Pt Pr. S	34	1~1000	ms			
PB10	VFG	Speed forward gain value If the system runs smoothly in speed control mode, increasing the gain value will reduce the speed tracking errors. If the system has resonance in speed control mode, decreasing the gain value will reduce the mechanism vibration.	S	0	0 ~ 200	%			
PB11	CDP (* <table border="1" style="display: inline-table; vertical-align: middle;"> <tr> <td style="padding: 2px 5px;">0</td> <td style="padding: 2px 5px;">0</td> <td style="padding: 2px 5px;">x</td> </tr> </table>	0	0	x	Gain switch option x=0:Disable gain switching function x=1:Switch when CDP is ON. x=2:Position command frequency >= CDS setting x=3:Position error pulse >= CDS setting. x=4:Servo motor rotation speed >= CDS setting. x=5:Switch when CDP is OFF. x=6:Position command frequency <= CDS setting x=7:Position error pulse <= CDS setting x=8:Servo motor rotation speed <= CDS setting	Pt. Pr. S	0000h	0000h ~ 0008h	N/A
0	0	x							

No	Abbr.	Parameter function and description	mode	Default	Range	Unit
PB12	CDS	Gain switch condition The set value of the gain switching condition (kpps, pulse, rpm) is varied according to CDP setting, and the unit depends on the switching condition item.	Pt. Pr S	10	0 ~ 400000 0	kpps pulse rpm
PB13	CDT	Gain switch time constant The switching time constant is used to smooth the gain conversion, and is used to set the time constant when the CDP and CDS conditions are switched.	Pt. Pr S	1	0 ~ 1000	ms
PB14	GD2	Servo motor Load inertia ratio 2 This parameter is to set load inertia ratio to motor inertia ratio,which is only valid during gain switching.	Pt. Pr S	70	0 ~ 1200	0. 1 time
PB15	PG2	Position loop gain change ratio This parameter is to set position loop gain change ratio,and it's valid after the auto gain tuning function is disabled.	Pt. Pr	100	10 ~ 500	%
PB16	VG2	Speed loop gain change ratio This parameter is to set speed loop gain change ratio,and it's valid after the auto gain tuning function is disabled.	Pt. Pr. S	100	10 ~ 500	%
PB17	VIC2	Speed integral gain change ratio This parameter is to set Speed integral gain change ratio,and it's only valid after the auto gain tuning function is disabled.	Pt. Pr S	100	10 ~ 500	%
PB18	SFLT	Speed command low-pass filter smooth time constant	S. T	0	0 ~	ms

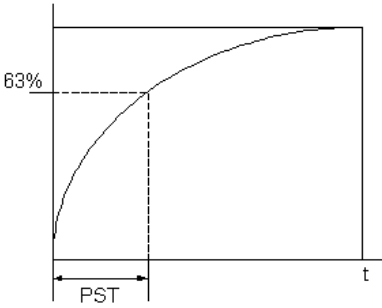
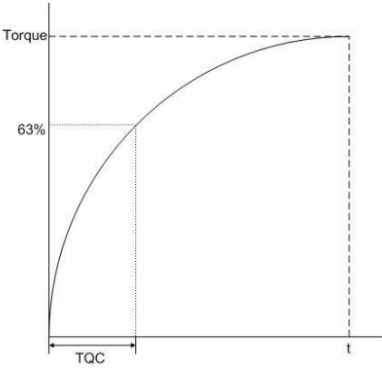
		<p>Increasing time constant will smooth the speed command curve, but it will reduce the response speed.</p> <p>0:this function is disabled.</p> <p>target potision</p>  <p>The actual time to reach the speed command is around 5 times SFLT.</p>			1000	
PB19	TQC	<p>Torque command filter time constant</p> <p>This parameter is to set time constant of torque command filter. With an appropriate setting, the motor can run smoothly when the servo drive encounters a sudden change of torque command.</p>  <p>The actual time reach to torque command is 5 times TQC.</p>	T	0	0 ~ 5000	ms
PB20	SJIT	<p>Speed feedback filter time constant</p> <p>This parameter is to set speed feedback filter time constant.</p>	All	0	0 ~ 1000	0. 1ms

No	Abbr.	Parameter function and description	mode	Default	Range	Unit
PB21	NHF2	Frequency of machine resonance suppression filter 2 This parameter is to set the frequency of machine resonance suppression filter, and the usage is the same as PB01.	All	1000	10 ~ 4000	Hz
PB22	NHD2	Attenuation of machine resonance suppression filter 2 This parameter is to set the attenuation of machine resonance suppression filter and it should use together with NHF2. 0:turn off Notch filter function	All	0	0 ~ 32	dB
PB23	IGE (▲)	Current gain enhancement function 0: turn off 1: turn on(it can improve the current response, but may cause resonance.	All	0	0 ~ 1	N/A
PB24	VDC	Speed differential compensation This parameter is to set speed differential compensation, it's valid when digital input proportional control signal is ON.	Pr. Pt S	980	0 ~ 1000	N/A
PB25	NHF3	Frequency of machine resonance suppression filter 3 This parameter is to set the frequency of machine resonance suppression filter, its usage is the same as PB01.	All	1000	10 ~ 4000	Hz

No	Abbr.	Parameter function and description	mode	Default	Range	Unit
PB26	NHD3	Attenuation of machine resonance suppression filter 2 This parameter is to set attenuation of machine resonance suppression filter and it should use together with NHF3. 0:turn off Notch filter function	All	0	0 ~ 32	dB
PB27	ANCF	Auto resonance suppression mode setting(Set for resonance suppression filter 1 and 2) 0:Fixed. 1: Automatically fixed after vibration suppression 2:keep auto vibration suppression.	All	0	0 ~ 2	N/A
PB28	ANCL	Auto resonance suppression detection level The larger the setting is, the lower resonance sensitivity will be. On the other hand, The smaller the setting is, the higher resonance sensitivity will be.	All	50	1 ~ 300	%
PB29	AVSM	Auto low frequency vibration suppression mode 0:Fixed. 1:Automatically fixed after vibration suppression Auto mode description: When the value is 1, it will automatically perform vibration suppression. When the vibration cannot be detected or the frequency is stable, the system resets the parameter to 0 and automatically saves the low-frequency vibration suppression frequency to PB31(VSF1)	Pr. Pt	0	0 ~ 1	N/A

PB30	VCL	<p>Low-frequency vibration detection level setting</p> <p>When automatic vibration suppression is enabled (PB29=1), the system will automatically search the detection level. The lower the value, the more sensitive the detection will be, but the system may also misjudge noise or take other low-frequency vibrations as frequencies to be suppressed. If the value is high, it's much easier for the system to judge, but the system may cannot easily detect low-frequency vibrations.</p>	Pr. Pt	50	1 ~ 8000	puls e
PB31	VSF1	<p>Low frequency vibration suppression frequency setting 1</p> <p>To set the first low-frequency vibration suppression frequency. When PB31 is 0, the first low frequency vibration suppression filter is disabled</p>	Pr. Pt	100	1 ~ 3000	0. 1Hz
PB32	VSG1	<p>Low frequency vibration suppression gain 1</p> <p>To set the first low-frequency vibration suppression gain. Increasing the value can improve the position response, but if the setting value is too large, the motor will not run smoothly. So it is recommended to set to 1.</p>	Pr. Pt	0	0 ~ 15	N/A

No	Abbr.	Parameter function and description	mode	Default	Range	Unit
PB33	VSF2	Low-frequency vibration suppression frequency 2 To set the second low-frequency vibration suppression frequency. When PB33 is 0, the second low frequency vibration suppression filter is disabled	Pr. Pt	100	1 ~ 3000	0.1 Hz
PB34	VSG2	Low frequency vibration suppression gain 2 To set the second low-frequency vibration suppression gain. Increasing the value can improve the position response, but if the setting value is too large, the motor will not run smoothly. So it is recommended to set to 1.	Pr. Pt	0	0 ~ 15	N/A
PB35	FRCL	Friction compensation level Set friction compensation level (For the percentage of rated torque, 0 = turn off. Set to 1 or more will turn on the friction compensation function)	Pr. Pt S	0	0 ~ 100	%
PB36	FRCT	Friction compensation smoothing time constant To set friction compensation smoothing time constant.	Pr. Pt S	0	0 ~ 1000	ms
PB37	FRCM	Friction compensation mode option 0: the compensation value remains unchanged when motor speed is slower than the value of PC17. 1: the compensation value decrease to 0 when motor speed is slower than the value of PC17.	Pr. Pt S	0	0 ~ 1	N/A
PB38	FFCT	Position feed forward filter time constant Set the filter time constant when position feed forward gain is used.	Pr. Pt	0	0 ~ 1000	0. 1ms

No	Abbr.	Parameter function and description	mode	Default	Range	Unit
PB39 ~ PB43		Reserved				
PB44	PPD	Position loop differential gain value Increasing this gain value will improve the tractability of position command.	Pr. Pt	0	0 ~ 500	rad/s
PB45	NHF4	Frequency of machine resonance suppression filter 4 This parameter is to set the frequency of machine resonance suppression filter, its usage is the same as PB01.	All	1000	10 ~ 4000	Hz
PB46	NHD4	Attenuation of machine resonance suppression filter 4 This parameter is to set attenuation of machine resonance suppression filter and it should use together with NHF4. 0:turn off Notch filter function.	All	0	0 ~ 32	dB
PB47	NHF5	Frequency of machine resonance suppression filter 5 This parameter is to set the frequency of machine resonance suppression filter, its usage is the same as PB01.	All	1000	10 ~ 4000	Hz
PB48	NHD5	Attenuation of machine resonance suppression filter 5 This parameter is to set attenuation of machine resonance suppression filter and it should be used together with NHF5. 0:turn off Notch filter function.	All	0	0 ~ 32	dB

No	Abbr.	Parameter function and description	mode	Default	Range	Unit
PB49	DOB	External interference compensation gain In position mode, increasing this parameter setting value may reduce position overshoot. In speed mode, increasing this parameter setting value may reduce speed overshoot if the parameter value is too large, it might cause machinery vibration.	All	0	0 ~ 100	N/A
PB50	MVF	Position command average filter time constant 0:Disable 1~50:Enable the filter function	Pr. Pt	0	0 ~ 50	ms
PB51 ~ PB56	RND	Reserved for factory test only.				
PB57	TOF	z-axis torque compensation (*) When in z- axis applications with heavy loads, it will improve the load axis vibration status when the electromagnetic brake is released and servo SV is turned on. Note: Abnormal settings may cause system instability				

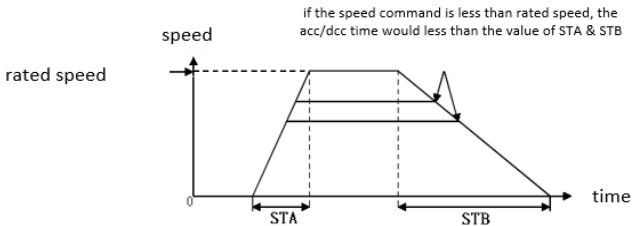
No	Abbr.	Parameter function and description	mode	Default	Range	Unit
PC01	STA	<p>Acceleration time constant</p> <p>The acceleration time required when the motor speed accelerates from 0 rpm to the rated motor speed is defined as the acceleration time constant. For example, if the servo motor rated speed is 3000 rpm, this parameter is set to 3000(3s). When the speed command is set to 1000 rpm, it takes 1 second for the motor to accelerate from 0 rpm to 1000 rpm.</p> <p>Please refer to section 6. 4. 3 for the instruction in Pr mode. The acceleration time in JOG mode is also set by this parameter.</p> <p>.</p> 	S. T	200	0 ~ 65550	ms
PC02	STB	<p>Deceleration time constant</p> <p>The deceleration time required when the motor speed decelerates from rated speed to 0 rpm is defined as the deceleration time constant.</p> <p>Please refer to section 6. 4. 3 for the operation in Pr mode. The deceleration time in JOG mode is also set by this parameter.</p>	S. T	200	0 ~ 65550	ms
PC03	STC	<p>S-curve acceleration /deceleration time constant</p> <p>During acceleration and deceleration, a three-stage acceleration and deceleration curve is adopted to provide smooth processing. An</p>	Pr S. T	0	0 ~ 10000	ms

		<p>appropriate STC setting can improve the stability of the motor when starting and stopping.</p> <p>In order to make the command curve smoother, the S curve can be added, and there will be a slight deviation in the acceleration and deceleration time.</p> <p>The time of motor accelerate to speed command = STA + STC.</p> <p>The time of motor decelerate from the speed command to 0 = STB + STC.</p>				
PC04	JOG	<p>JOG speed command</p> <p>This parameter is JOG speed setting in JOG operation mode.</p>	All	300	0 ~ 6000	rpm
PC05	SC1	<p>Internal speed command 1(Limit 1)</p> <p>In speed control mode, this parameter is speed command 1. In torque control mode, this parameter is speed limit 1 and without direction. The maximum internal speed command value is the maximum speed value of motor.</p>	S. T	100	-6000 ~ 6000	rpm
PC06	SC2	<p>Internal speed command 2(Limit 2)</p> <p>In speed control mode, this parameter is speed command 2. In torque control mode, this parameter is speed limit 2 and without direction. The maximum internal speed command value is the maximum speed value of motor.</p>	S. T	500	-6000 ~ 6000	rpm

No	Abbr.	Parameter function and description	mode	Default	Range	Unit
PC07	SC3	Internal speed command 3(Limit 3) In speed control mode, this parameter is speed command 3. In torque control mode, this parameter is speed limit 3 and without direction. The maximum internal speed command value is the maximum speed value of motor.	S. T	1000	-6000 ~ 6000	rpm
PC08	SC4	Internal speed command 4(Limit 4) In speed control mode, this parameter is speed command 4. In torque control mode, this parameter is speed limit 4 and without direction. The maximum internal speed command value is the maximum speed value of motor.	S. T	200	-6000 ~ 6000	rpm
PC09	SC5	Internal speed command 5(Limit 5) In speed control mode, this parameter is speed command 5. In torque control mode, this parameter is speed limit 5 and without direction. The maximum internal speed command value is the maximum speed value of motor.	S. T	300	-6000 ~ 6000	rpm
PC10	SC6	Internal speed command 6(Limit 6) In speed control mode, this parameter is speed command 6. In torque control mode, this parameter is speed limit 6 and without direction. The maximum internal speed command value is the maximum speed value of motor.	S. T	500	-6000 ~ 6000	rpm
PC11	SC7	Internal speed command 7(Limit 7) In speed control mode, this parameter is speed command 7. In torque control mode, this parameter is speed limit 7 and without direction. The maximum internal speed command value is the maximum speed value of motor.	S. T	800	-6000 ~ 6000	rpm

No	Abbr.	Parameter function and description	mode	Default	Range	Unit				
PC12 ~ PC15		Reserved								
PC16	MBR	<p>Electromagnetic brake sequence output time</p> <p>If PC16\geq0, it sets the delay time which counts from SON turning off to the electromagnetic brake interlock signal (MBR) turning off.</p> <p>If PC16$<$0, it sets the delay time of SON on. After the electromagnetic brake interlock signal (MBR) is turned off, and then the SON will turn off after the delay time.</p>	All	100	-1000 ~ 1000	ms				
PC17	ZSP	<p>Zero speed signal acknowledged range</p> <p>To set the zero speed signal output speed range. If the forward/reverse rotation speed of motor is lower than this parameter setting value, the ZSP of DO will be outputted from the zero speed signal contact.</p>	All	50	0 ~ 10000	rpm				
PC18	COP1 (*)	<p>Stop option and power interruption and restart option</p> <div style="border: 1px solid black; display: inline-block; padding: 2px; margin: 10px 0;"> <table border="1" style="border-collapse: collapse;"> <tr> <td style="width: 20px; text-align: center;">0</td> <td style="width: 20px; text-align: center;">0</td> <td style="width: 20px; text-align: center;">y</td> <td style="width: 20px; text-align: center;">x</td> </tr> </table> </div> <p><u>x: power interruption and restart option</u></p> <p>When voltage of power is lower than allowable level, insufficient voltage alarm occurs and servo motor stops. The servo motor will restart immediately when power voltage is normal and alarm reset is not needed.</p> <p>0 : invalid 1 : valid</p>	0	0	y	x	All	0010h	0000h ~ 0011h	N/A
0	0	y	x							

		<p><u>y: Motor stop mode option. Servo stop selection in speed control mode.</u></p> <p>y=1: motor stops instantaneously</p> <p>y=0: decelerates to stop</p>								
PC19	COP2 (*)	<p>Alarm history clear option and overload early warning option.</p> <table border="1" style="margin-left: 40px;"> <tr> <td style="width: 20px; text-align: center;">0</td> <td style="width: 20px; text-align: center;">z</td> <td style="width: 20px; text-align: center;">y</td> <td style="width: 20px; text-align: center;">x</td> </tr> </table> <p>x=0: not clear alarm history x=1: clear alarm history</p> <p>When set x=1, the clear action will only be performed after the power is restarted next time, and it will be automatically set to 0 after the clear is completed.</p> <p>y=0: no action when warning occurs.</p> <p>y=1: motor stops immediately when warning occurs</p> <p>z=0: the display stays in alarm screen after alarm is cleared.</p> <p>z=1: the display go back to the previous screen after alarm is cleared.</p>	0	z	y	x	All	0000h	0000h ~ 0111h	N/A
0	z	y	x							
PC20	SNO (*)	<p>Servo drive communication device number</p> <p>Setting different address for different servo drive during communication. If two drives are set to the same device number, it will cause communication failure.</p> <p>Note: When using the communication control to write parameters frequently, please set PA23 and study PA23 parameter description carefully to avoid EEPROM damage caused by continuous communication writing.</p>	All	1	1 ~ 32	number				

No	Abbr.	Parameter function and description	mode	Default	Range	Unit				
PC21	CMS (*)	<p>communication mode option</p> <p>0: Reply within 1ms delay. -1:for factory test only. 1: Reply after 1ms delay. 2:Reply after 2ms delay</p> <p>Note: When using the communication control to write parameters frequently, please set PA23 and study PA23 parameter description carefully to avoid EEPROM damage caused by continuous communication writing.</p>	All	0	-1 ~ 2	N/A				
PC22	BPS (*)	<p>Communication protocol option</p> <table border="1" style="margin-left: 20px;"> <tr> <td style="width: 20px; text-align: center;">0</td> <td style="width: 20px; text-align: center;">0</td> <td style="width: 20px; text-align: center;">y</td> <td style="width: 20px; text-align: center;">x</td> </tr> </table> <p><u>y: RS-485 communication speed option</u> y=0:4800bps y=1:9600bps y=2:19200bps y=3:38400bps y=4:57600bps y=5:115200bps</p> <p><u>x: Communication protocol option</u> x=0: 7,N,2(Modbus, ASCII) x=1: 7,E,1(Modbus, ASCII) x=2: 7,O,1(Modbus, ASCII) x=3: 8,N,2(Modbus, ASCII) x=4: 8,E,1(Modbus, ASCII) x=5: 8,O,1(Modbus, ASCII) x=6: 8,N,2(Modbus, RTU) x=7: 8,E,1(Modbus, RTU) x=8: 8,O,1(Modbus, RTU)</p> <p>Note: When using the communication control to write parameters frequently, please set PA23 and study PA23 parameter description carefully to avoid EEPROM damage caused by continuous communication writing.</p>	0	0	y	x	All	0010h	0000h ~ 0058h	N/A
0	0	y	x							
PC23	SIC	<p>Serial communication timeout option</p> <p>The timeout duration of the communication protocol can be set from 1 to 60 seconds. If it is set to 0, the servo drive will not check the time out.</p>	All	0	0 ~ 60	s				

No	Abbr.	Parameter function and description	mode	Default	Range	Unit			
PC24	DMD (*)	<p>Drive status display option</p> <table border="1" style="margin-left: 20px;"> <tr> <td style="width: 20px; text-align: center;">0</td> <td style="width: 20px; text-align: center;">y</td> <td style="width: 20px; text-align: center;">x</td> </tr> </table> <p><u>x: Display option after power on(hexadecimal)</u></p> <p>x=0:Motor feedback pulse number (high 5-digit) (before electronic gear ratio)</p> <p>x=1:Motor feedback pulse number (low 5-digit) (before electronic gear ratio)</p> <p>x=2: Pulse number of pulse position commands (high 5-digit) (before electronic gear ratio)</p> <p>x=3:Pulse number of pulse position commands (low 5-digit) (before electronic gear ratio)</p> <p>x=4:Input pulse command and feedback pulse deviation (before E-Gears)</p> <p>x=5:Pulse command input frequency</p> <p>x=6:current speed of motor</p> <p>x=7:Analog speed command/limit voltage</p> <p>x=8:Speed input command/limit</p> <p>x=9:Analog torque command /limit voltage</p> <p>x=A:Torque input command/limit</p> <p>x=B:Effective load rate</p> <p>x=C:Peak load rate</p> <p>x=D:DC Bus voltage</p> <p>x=E:Load inertia ratio to motor shaft</p> <p>x=F:Instantaneous torque</p> <p>x=10:Regenerative load rate</p> <p>x=11:Absolute pulse number reference Z phase</p>	0	y	x	All	0000h	0000h ~ 0111h	N/A
0	y	x							

y: Status display according to the control mode after power on

y=1: Display status according x setting value of PC24.

y=0: The drive status is displayed according to the control mode, and the display status in different control modes is shown in the following table.

Control mode	The drive status displayed after power on
Position	Motor feedback pulse number(Note 1)
Position and speed dual mode	Motor feedback pulse number(Note 1)/motor speed
Speed	Motor speed
Speed and torque dual mode	Motor speed/analog torque command voltage
torque	Torque command
Torque and position dual mode	Torque command/motor feedback pulse number(note1)

Note 1: Display the motor feedback pulse number after electronic gear ratio (low 5-digit)

No	Abbr.	Parameter function and description	mode	Default	Range	Unit
PC25	TL2	Internal torque limit 2 The setting description is the same as PA05. In addition, when using the internal parameter torque limit with external input signals TL and TL1, different torque limits can be selected. Please refer to PA05 description.	All	100	0 ~ 100	%
PC26 ~ PC31						
PC32	CMX2	Electronic gear numerator 2 To set electronic gear numerator 2 Refer to section 6. 4. 4	Pt	1	1 ~ 2^{26}	N/A
PC33	CMX3	Electronic gear numerator 3 To set electronic gear numerator 3	Pt	1	1 ~ 2^{26}	N/A
PC34	CMX4	Electronic gear numerator 4 To set electronic gear numerator 4	Pt	1	1 ~ 2^{26}	N/A
PC35		Reserved				
PC36		Reserved				
PC37	DTA9 (*)	AL.09 initialization delay judgement time To set AL.09 judgement delay time when boot up. The setting value 0 indicates this function is disabled.	All	0	0 ~ 20000	ms

No	Abbr.	Parameter function and description	mode	Default	Range	Unit				
PC38	FNO4 (*)	<p>Function option 4</p> <p>To define the contact pin for DO1~DO5 output signal during initialization.</p> <p>Bit0~bit5 of this parameter controls DO1~DO5 output contact status.</p> <p>0 :initiate output contact as a contact</p> <p>1 :initiate output contact as b contact</p> <p>If this parameter used in DO3:ALM, set PC38 =0020h and the b contact output will be 0.5-1second earlier when boot up.</p>	All	0000h	0000h ~ 003Fh	N/A				
PC39	LPS	<p>Low pass filter setting option</p> <table border="1" style="margin: 10px auto;"> <tr> <td style="padding: 2px 5px;">0</td> <td style="padding: 2px 5px;">0</td> <td style="padding: 2px 5px;">0</td> <td style="padding: 2px 5px;">x</td> </tr> </table> <p>When X=0, PB03 value will be varied with PA02 setting automatically(invalid when PA02=0)</p> <p>When x=1, PB03 need to be set manually.</p>	0	0	0	x	All	0000h	0000h ~ 0001h	N/A
0	0	0	x							
PC40	MBR2	<p>The delay time to release electromagnetic brake MBR when Servo ON.</p> <p>When the electromagnetic brake function is enabled, this parameter is to define the delay output time of the electromagnetic brake interlock signal (MBR) turning on after SON is activated</p>	All	0	0 ~ 1000	ms				
PC41	MP1A	<p>Object parameter PC57 mapping</p> <p>The target of the mapping parameter is the parameter address specified by the user. With a 32-bit length, it can be set to map two 16-bit parameters or one 32-bit parameter.</p>	All	0000h	Note *	N/A				

		<p>If PC41 is set as 0x01010101, it means the mapped data in PC57 is the content of PA01.</p> <table border="1"> <thead> <tr> <th></th> <th>HIGH</th> <th>LOW</th> </tr> </thead> <tbody> <tr> <td>PC41</td> <td>0x0101</td> <td>0x0101</td> </tr> <tr> <td>PC57</td> <td colspan="2">PA01(32-bit)</td> </tr> </tbody> </table> <p>If PC41 is set to 0x01010112, it means the mapped data in PC57 is PA01(16-bit) and PA12(16-bit).</p> <table border="1"> <thead> <tr> <th></th> <th>HIGH</th> <th>LOW</th> </tr> </thead> <tbody> <tr> <td>PC41</td> <td>0x0101</td> <td>0x0112</td> </tr> <tr> <td>PC57</td> <td>PA01(16 bits)</td> <td>PA12(16 bits)</td> </tr> </tbody> </table> <p>For example</p> <p>Set PC41 to 0x0110 if mapping target is PA10</p> <p>Set PC41 to 0x0424 if mapping target is PD24, and you can refer to the mapping parameters list in the following 2 pages.</p> <p>※Default value is 0x00 which indicate mapping function is disabled.</p> <p>※It can directly map status parameter.</p>		HIGH	LOW	PC41	0x0101	0x0101	PC57	PA01(32-bit)			HIGH	LOW	PC41	0x0101	0x0112	PC57	PA01(16 bits)	PA12(16 bits)				
	HIGH	LOW																						
PC41	0x0101	0x0101																						
PC57	PA01(32-bit)																							
	HIGH	LOW																						
PC41	0x0101	0x0112																						
PC57	PA01(16 bits)	PA12(16 bits)																						
PC42	MP2A	Object parameter PC58 mapping The setting is the same as PC41	All	0000h	Note *	N/A																		
PC43	MP3A	Object parameter PC59 mapping The setting is the same as PC41		0000h																				
PC44	MP4A	Object parameter PC60 mapping The setting is the same as PC41		0000h																				

No	Abbr.	Parameter function and description	mode	Default	Range	Unit
PC45	MP5A	Object parameter PC61 mapping The setting is the same as PC41	All	0000h	Note *	N/A
PC46	MP6A	Object parameter PC62 mapping The setting is the same as PC41		0000h		
PC47	MP7A	Object parameter PC63 mapping The setting is the same as PC41		0000h		
PC48	MP8A	Object parameter PC64 mapping The setting is the same as PC41		0000h		
PC49	MS1A	Object status display 1 mapping This is used to designate the address of object parameter, The data length of PC49 is 32-bit, Refer to the mapping status number in the following page Mapping Status Display Target Table. For example If set PC49 = 0x05, PC65 reads “motor current speed(r/min)” ※All the status is Read only.	All	0000h	0000h ~ 00FFh	N/A
PC50	MS2A	Object status display 2 mapping The setting is the same as PC49. Read PC66 to return the status value.	All	0000h	0000h ~ 00FFh	N/A
PC51	MS3A	Object status display 3 mapping The setting is the same as PC49. Read PC67 to return the status value.		0000h	0000h ~ 00FFh	

PC52	MS4A	Object status display 4 mapping The setting is the same as PC49. Read PC68 to return the status value.		0000h	0000h ~ 00FFh	
PC53	MS5A	Object status display 5 mapping The setting is the same as PC49. Read PC69 to return the status value.		0000h	0000h ~ 00FFh	
PC54 ~ PC56		Reserved				

Note *: Depends on the communication address of the parameter.

Mapping parameters List

The following table shows the number of each group mapping parameter.

Parameter number	Mapping number	Parameter number	Mapping number	Parameter number	Mapping number	Parameter number	Mapping number
PA01	0x0101	PB01	0x0201	PC01	0x0301	PD01	0x0401
PA02	0x0102	PB02	0x0202	PC02	0x0302	PD01	0x0402
~	~	~	~	~	~	~	~
PA50	0x0150	PB60	0x0260	PC99	0x0399	PD40	0x0440

Parameter number	Mapping number	Parameter number	Mapping number
PE01	0x0501	PF01	0x0601
PE02	0x0502	PF02	0x0602
~	~	~	~
PE99	0x0599	PF99	0x0699

Note: The low-bit(two digits) of the mapping number is the same as the parameter number.

Relevant alarm

Alarm Code	Alarm item	Issue description	Solution
AL.61	Input group error	Write the wrong mapping number of PC41~PC48.	This error will continue to appear, you need to troubleshoot the problem before you can press the SET button to release.
AL.62	Input number error	Write the wrong mapping number of PC41~PC48.	You need to troubleshoot the problem before you can press the SET button to release.
AL.63	Writing range error	Write the wrong mapping range of PC57~PC64.	Press the SET button to release.
AL.64	Not writable when SON is ON	Write PC57~PC64 with the inhibit parameters when SON is ON.	Press the SET button to release.

※None of the above alarms affect the operation of the drive.

Mapping status display target list.

Status number (Hexadecimal)	Content
00H	Undefined
01H	Motor feedback pulse number (before electronic gear ratio)
02H	The number of pulse commands(before electronic gear ratio)
03H	The deviation of input pulse command and feedback pulse (before E-Gears)
04H	Pulse command input frequency
05H	Motor current speed.
06H	Analog speed command/limit voltage
07H	Speed input command/limit
08H	Analog torque command/limit voltage
09H	Torque input command/limit
0AH	Effective load rate
0BH	Peak load rate
0CH	DC bus voltage
0DH	Load inertia ratio to motor shaft
0EH	Instantaneous torque
0FH	Regenerative load rate
10H	Absolute pulse number reference Z phase
11H	Refer to the mapping DIO status table below for DI/DO status output,
12H	Refer to section 10. 1 for the current alarm

Mapping DI/DO status list(Read only)

Bit7	Bit6	Bit5	Bit4	Bit3	Bit2	Bit1	Bit0	Bit number
			DO5	DO4	DO3	DO2	DO1	Pin number
Bit15	Bit14	Bit13	Bit12	Bit11	Bit10	Bit9	Bit8	Bit number
								Pin number
Bit23	Bit22	Bit21	Bit20	Bit19	Bit18	Bit17	Bit16	Bit number
DI8	DI7	DI6	DI5	DI4	DI3	DI2	DI1	Pin number
Bit31	Bit30	Bit29	Bit28	Bit27	Bit26	Bit25	Bit24	Bit number
							DI9	Pin number

No	Abbr.	Parameter function and description	mode	Default	Range	Unit
PC57	MP1	<p>Mapping parameter #1</p> <p>To help users to quick and continuous read and write scattered parameter addresses.</p> <p>PC41 is set to the mapping parameter number by the panel or communication. When the users read and write PC57, it is equivalent to read and write the parameter specified by PC41.</p> <p>※When writing to the specified parameter, it will not be written to the EEPROM.</p>	All	0000h	Note *	N/A
PC58	MP2	<p>Mapping parameter#2</p> <p>The setting is the same as PC57, and the mapping target parameter is determined by PC42.</p>	All	0000h	Note *	N/A
PC59	MP3	<p>Mapping parameter#3</p> <p>The setting is the same as PC57, and the mapping target parameter is determined by PC43.</p>	All	0000h	Note *	N/A
PC60	MP4	<p>Mapping parameter#4</p> <p>The setting is the same as PC57, and the mapping target parameter is determined by PC44.</p>	All	0000h	Note *	N/A
PC61	MP5	<p>Mapping parameter#5</p> <p>The setting is the same as PC57, and the mapping target parameter is determined by PC45.</p>	All	0000h	Note *	N/A
PC62	MP6	<p>Mapping parameter#6</p> <p>The setting is the same as PC57, and the mapping target parameter is determined by PC46.</p>	All	0000h	Note *	N/A

No	Abbr.	Parameter function and description	mode	Default	Range	Unit
PC63	MP7	Mapping parameter#7 The setting is the same as PC57, and the mapping target parameter is determined by PC47.	All	0000h	Note *	N/A
PC64	MP8	Mapping parameter#8 The setting is the same as PC57, and the mapping target parameter is determined by PC48.	All	0000h	Note *	N/A

Note *: Depends on the corresponding parameters of PC41~PC48.

No	Abbr.	Parameter function and description	mode	Default	Range	Unit
PC65	MS1	The content value of mapping status 1(read only) To help users to quick and continuous read and write scattered parameter addresses. PC49 is set to the mapping parameter number by the panel or communication. You can refer to the mapping status table. When reading PC65, it is equivalent to read the status value specified by PC49.	All	0	Note *	N/A
PC66	MS2	The content value of mapping status 2(this parameter is read only) The status data displayed is designated by the PC50 setting, which will be return after reading PC66 by communication.		0		
PC67	MS3	The content value of mapping status 3(this parameter is read only) The status data displayed is designated by the PC51 setting, which will be return after reading PC67 by communication.		0		
PC68	MS4	The content value of mapping status 4(this parameter is read only) The status data displayed is designated by the PC52 setting, which will be return after reading PC68 by communication.		0		
PC69	MS5	The content value of mapping status 5(this parameter is read only) The status data displayed is designated by the PC53 setting, which will be return after reading PC69 by communication.		0		
PC70 ~ PC72		Reserved				

No	Abbr.	Parameter function and description	mode	Default	Range	Unit
PC73	TQ1	Internal torque command 1 The first internal torque command (100% indicates rated torque)	T	100	-300 ~ 300	%
PC74	TQ2	Internal torque command 2 The second internal torque command (100% indicates rated torque)	T	100	-300 ~ 300	%
PC75	TQ3	Internal torque command 3 The third internal torque command (100% indicates rated torque)	T	100	-300 ~ 300	%

Note *: The corresponding state determines the range.

No	Abbr.	Parameter function and description	mode	Default	Range	Unit				
PD01	DIA1 (*)	Input signal automatic ON option 1 <table border="1" style="margin-left: 20px;"> <tr> <td style="padding: 2px 5px;">u</td> <td style="padding: 2px 5px;">z</td> <td style="padding: 2px 5px;">y</td> <td style="padding: 2px 5px;">x</td> </tr> </table> x=0: The SON-SG circuit open/short option is controlled by the external circuit of the driver. x=1: SON-SG is short-circuited internally without external wiring. y=0: The LSP-SG open/short option is controlled by the external circuit of the driver. y=1: LSP-SG is short-circuited internally without external wiring. z=0: The LSN-SG circuit open/short option is controlled by the external circuit of the driver. z=1: LSN-SG is short-circuited internally without external wiring. u=0: The EMG-SG circuit open/short option is controlled by the external circuit of the driver. u=1: EMG-SG is short-circuited internally without external wiring.	u	z	y	x	All	0000h	0000h ~ 1111h	N/A
u	z	y	x							
PD02	DI1 (*)	Input signal option 1 To define the input signal for CN1-14 pin. In different control modes, the input signals are not exactly the same. The user can define CN1-14 function in different control mode by setting this parameter.	All	0001h	0000h ~ 003Fh	N/A				
PD03	DI2 (*)	Input signal option 2 To define the input signal for CN1-15 pin. CN1-15 pin can be defined as any input signal and its parameter setting is the same as PD02, you can refer to PD02 setting description.	All	000Dh	0000h ~ 003Fh	N/A				

PD04	DI3	Input signal option 3	All	0003h	0000h ~ 003Fh	N/A
	(*)	To define the input signal for CN1-16 pin. CN1-16 pin can be defined as any input signal and its parameter setting is the same as PD02, you can refer to PD02 setting description.				
PD05	DI4	Input signal option 4	All	0004h	0000h ~ 003Fh	N/A
	(*)	To define the input signal for CN1-17 pin. CN1-17 pin can be defined as any input signal and its parameter setting is the same as PD02, you can refer to PD02 setting description.				
PD06	DI5	Input signal option 5	All	0002h	0000h ~ 003Fh	N/A
	(*)	To assign the input signal for CN1-18 pin. CN1-18 pin can be defined as any input signal and its parameter setting is the same as PD02, you can refer to PD02 setting description.				
PD07	DI6	Input signal option 6	All	000Fh	0000h ~ 003Fh	N/A
	(*)	To assign the input signal for CN1-19 pin. CN1-19 pin can be defined as any input signal and its parameter setting is the same as PD02, you can refer to PD02 setting description.				
PD08	DI7	Input signal option 7	All	0012h	0000h ~ 003Fh	N/A
	(*)	To assign the input signal for CN1-20 pin. CN1-20 pin can be defined as any input signal and its parameter setting is the same as PD02, you can refer to PD02 setting description.				

No	Abbr.	Parameter function and description	mode	Default	Range	Unit
PD09	DI8 (*)	Input signal option 8 To assign the input signal for CN1-21 pin. CN1-21 pin can be defined as any input signal and its parameter setting is the same as PD02, you can refer to PD02 setting description.	All	0019h	0000h ~ 003Fh	N/A
PD10	DO1 (*)	Output signal option 1 To define the output signal for CN1-41 pin. In different control modes, the output signals are not exactly the same. The user can define CN1-41 function in different control mode by setting this parameter.	All	0003h	0000h ~ 003Fh	N/A
PD11	DO2 (*)	Output signal option 2 To define the output signal for CN1-42 pin. CN1-42 pin can be defined as any output signal and its parameter setting is the same as PD10, you can refer to PD10 setting description.	All	0008h	0000h ~ 003Fh	N/A
PD12	DO3 (*)	Output signal option 3 To define the output signal for CN1-43 pin. CN1-43 pin can be defined as any output signal and its parameter setting is the same as PD10, you can refer to PD10 setting description.	All	0002h	0000h ~ 003Fh	N/A
PD13	DO4 (*)	Output signal option 4 To define the output signal for CN1-44 pin. CN1-44 pin can be defined as any output signal and its parameter setting is the same as PD10, you can refer to PD10 setting description.	All	0005h	0000h ~ 003Fh	N/A
PD14	DO5 (*)	Output signal option 5 To define the output signal for CN1-45 pin. CN1-45 pin can be defined as any output signal and its parameter setting is the same as PD10, you can refer to PD10 setting description.	All	0001h	0000h ~ 003Fh	N/A

PD15	DIF (*)	Digital input filter setting 1 unit is 2ms. if PD15=5, it means filter time is 10ms.	All	2	0 ~ 50	2ms				
PD16	SDI (■)	Digital input control source option Each bit of this parameter determines the signal input control source of 1 DI. Bit0 ~ Bit8 correspond to DI1 ~ DI9 Bit setting shows as below: 0: input contact status is controlled by external hardware terminal. 1: input contact status is controlled by communication(PD25) For DI function definition, please refer to DI1 ~ DI8:PD02 ~ PD09 DI9:PD21	All	0000h	0000h ~ 01FFh	N/A				
PD17	DOP1 (*)	The servo emergency stop mode setting when LSN or LSP signal is off. <table border="1" style="display: inline-table; vertical-align: middle;"> <tr> <td style="padding: 2px 5px;">0</td> <td style="padding: 2px 5px;">0</td> <td style="padding: 2px 5px;">0</td> <td style="padding: 2px 5px;">x</td> </tr> </table> <u>x:Options of emergency stop</u> x=0: stops immediately. x=1: Servo decelerates to stop according to the decelerate time constant setting. The decelerate time is set according to PF81(Deceleration time for auto-protection)	0	0	0	x	Pt. Pr S.	0000h	0000h ~ 0001h	N/A
0	0	0	x							

No	Abbr.	Parameter function and description	mode	Default	Range	Unit				
PD18	DOP2 (*)	<p data-bbox="336 293 660 327">CR signal clear setting</p> <div data-bbox="375 353 568 430" style="border: 1px solid black; padding: 5px; display: inline-block; margin: 10px 0;"> <table border="1" style="border-collapse: collapse;"> <tr> <td style="padding: 2px 10px;">0</td> <td style="padding: 2px 10px;">0</td> <td style="padding: 2px 10px;">0</td> <td style="padding: 2px 10px;">x</td> </tr> </table> </div> <p data-bbox="336 512 1050 651">x=0: To clear the position pulse error. When CR is triggered at the rising edge, the driver's position pulse error will be cleared to 0 (Pt mode).</p> <p data-bbox="336 689 1031 828">x=1: To clear the position pulse error. When CR-SG is short-circuited, the position pulse error of drive will keep cleaning to 0 (Pt mode)</p> <p data-bbox="336 866 1054 1211">x=2: To stop the positioning function. the CR is triggered at the rising edge, the motor will decelerate to stop according to the deceleration time and the remaining uncompleted pulses will be ignored. When CTRG-SG is short-circuited again, the current position command will be executed (Pr mode)</p> <div data-bbox="445 1270 975 1581" style="text-align: center;"> <p>The diagram illustrates the relationship between CTRG, CR, and Moving distance. CTRG (Clear Trigger) has two pulses labeled 'ON'. CR (Clear Remainder) has one pulse labeled 'ON'. Moving distance shows a ramp up, a plateau, and a second ramp up. A dashed line labeled 'Clear remainder' indicates the end of the first plateau.</p> </div>	0	0	0	x	Pt. Pr	0000h	0000h ~ 0002h	N/A
0	0	0	x							

PD19	DOP3	<p>Alarm code output option</p> <p>(*)</p> <table border="1" data-bbox="375 257 582 336"> <tr> <td>0</td> <td>0</td> <td>0</td> <td>x</td> </tr> </table> <table border="1" data-bbox="336 414 949 672"> <thead> <tr> <th rowspan="2">x</th> <th colspan="3">Pin number</th> </tr> <tr> <th>CN1-41</th> <th>CN1-42</th> <th>CN1-45</th> </tr> </thead> <tbody> <tr> <td>Setting</td> <td></td> <td></td> <td></td> </tr> <tr> <td>0</td> <td>DO function</td> <td>DO function</td> <td>DO function</td> </tr> <tr> <td>1</td> <td colspan="3">alarm code when an alarm occurs</td> </tr> </tbody> </table> <p>Note: DO function is determined by PD10 ~ PD14 setting.</p> <table border="1" data-bbox="391 750 997 2016"> <thead> <tr> <th colspan="3">(Note) Alarm code</th> <th rowspan="2">Alarm display</th> <th rowspan="2">Name</th> </tr> <tr> <th>CN1-41</th> <th>CN1-42</th> <th>CN1-45</th> </tr> </thead> <tbody> <tr> <td rowspan="5">0</td> <td rowspan="5">0</td> <td rowspan="5">0</td> <td>AL.09</td> <td>Serial communication error</td> </tr> <tr> <td>AL.0A</td> <td>Serial communication timeout</td> </tr> <tr> <td>AL.0E</td> <td>IGBT overheat</td> </tr> <tr> <td>AL.0F</td> <td>Memory error</td> </tr> <tr> <td>AL.10</td> <td>Overload 2</td> </tr> <tr> <td>0</td> <td>0</td> <td>1</td> <td>AL.02</td> <td>Low voltage</td> </tr> <tr> <td rowspan="2">0</td> <td rowspan="2">1</td> <td rowspan="2">0</td> <td>AL.01</td> <td>Over voltage</td> </tr> <tr> <td>AL.04</td> <td>Regenerative alarm</td> </tr> <tr> <td>0</td> <td>1</td> <td>1</td> <td>AL.03</td> <td>Over current</td> </tr> <tr> <td>1</td> <td>0</td> <td>0</td> <td>AL.05</td> <td>Overload</td> </tr> <tr> <td rowspan="3">1</td> <td rowspan="3">0</td> <td rowspan="3">1</td> <td>AL.06</td> <td>Over speed</td> </tr> <tr> <td>AL.07</td> <td>Pulse command abnormal</td> </tr> <tr> <td>AL.08</td> <td>Position error excess</td> </tr> <tr> <td rowspan="2">1</td> <td rowspan="2">1</td> <td rowspan="2">0</td> <td>AL.0B</td> <td>Encoder error 1</td> </tr> <tr> <td>AL.0C</td> <td>Encoder error 2</td> </tr> </tbody> </table> <p>Note: 0: OFF, 1: ON</p>	0	0	0	x	x	Pin number			CN1-41	CN1-42	CN1-45	Setting				0	DO function	DO function	DO function	1	alarm code when an alarm occurs			(Note) Alarm code			Alarm display	Name	CN1-41	CN1-42	CN1-45	0	0	0	AL.09	Serial communication error	AL.0A	Serial communication timeout	AL.0E	IGBT overheat	AL.0F	Memory error	AL.10	Overload 2	0	0	1	AL.02	Low voltage	0	1	0	AL.01	Over voltage	AL.04	Regenerative alarm	0	1	1	AL.03	Over current	1	0	0	AL.05	Overload	1	0	1	AL.06	Over speed	AL.07	Pulse command abnormal	AL.08	Position error excess	1	1	0	AL.0B	Encoder error 1	AL.0C	Encoder error 2	All	0000h	0000h ~ 0001h	N/A
0	0	0	x																																																																																					
x	Pin number																																																																																							
	CN1-41	CN1-42	CN1-45																																																																																					
Setting																																																																																								
0	DO function	DO function	DO function																																																																																					
1	alarm code when an alarm occurs																																																																																							
(Note) Alarm code			Alarm display	Name																																																																																				
CN1-41	CN1-42	CN1-45																																																																																						
0	0	0	AL.09	Serial communication error																																																																																				
			AL.0A	Serial communication timeout																																																																																				
			AL.0E	IGBT overheat																																																																																				
			AL.0F	Memory error																																																																																				
			AL.10	Overload 2																																																																																				
0	0	1	AL.02	Low voltage																																																																																				
0	1	0	AL.01	Over voltage																																																																																				
			AL.04	Regenerative alarm																																																																																				
0	1	1	AL.03	Over current																																																																																				
1	0	0	AL.05	Overload																																																																																				
1	0	1	AL.06	Over speed																																																																																				
			AL.07	Pulse command abnormal																																																																																				
			AL.08	Position error excess																																																																																				
1	1	0	AL.0B	Encoder error 1																																																																																				
			AL.0C	Encoder error 2																																																																																				

No	Abbr.	Parameter function and description	mode	Default	Range	Unit												
PD20	DOP4 (*)	<p>Operation option when the alarm reset signal is short-circuited.</p> <table border="1" style="margin-left: 20px;"> <tr> <td style="width: 20px; text-align: center;">0</td> <td style="width: 20px; text-align: center;">0</td> <td style="width: 20px; text-align: center;">y</td> <td style="width: 20px; text-align: center;">x</td> </tr> </table> <p>x=0: PWM signal off(SEVO ON is disabled) x=1: PWM signal on(SERVO ON is enabled)</p> <p>Options of output signal when warning occurs To select ALM output status when warning occurs. y=0: disable ALM when warning occurs y=1: enable ALM when warning occurs</p> <div style="border: 1px solid black; padding: 5px; margin: 10px 0;"> <table style="width: 100%; border-collapse: collapse;"> <tr> <td style="width: 15%; padding: 5px;">PD20.y = 0</td> <td style="padding: 5px;"> DO:WNG ON OFF DO:ALM ON OFF </td> <td style="width: 10%; text-align: center; vertical-align: middle;"> ↓ Alarm occurs </td> <td style="width: 65%;"></td> </tr> <tr> <td style="padding: 5px;">PD20.y = 1</td> <td style="padding: 5px;"> DO:WNG ON OFF DO:ALM ON OFF </td> <td></td> <td></td> </tr> </table> </div> <p>This timing diagram DO: ALM is b contact output.</p>	0	0	y	x	PD20.y = 0	DO:WNG ON OFF DO:ALM ON OFF	↓ Alarm occurs		PD20.y = 1	DO:WNG ON OFF DO:ALM ON OFF			All	0000h	0000h ~ 0011h	N/A
0	0	y	x															
PD20.y = 0	DO:WNG ON OFF DO:ALM ON OFF	↓ Alarm occurs																
PD20.y = 1	DO:WNG ON OFF DO:ALM ON OFF																	
PD21	DI9 (*)	<p>Input signal option 9</p> <p>To define the input signal for CN1-22 pin. CN1-22 pin can be defined as any input signal and its parameter setting is the same as PD02, you can refer to PD02 setting description.</p>	All	0018h	0000h ~ 003Fh	N/A												
PD22 ~ PD24		Reserved																

No	Abbr.	Parameter function and description	mode	Default	Range	Unit
PD25	ITST	<p>Communication control digital input status</p> <p>(■) To determine the digital input contact (12 points in total) by bit setting method. Bit 0~8 of PD25 is correspond to DI1~DI9.</p> <p>In binary bits: 0: digital input contact OFF 1: digital input contact ON.</p> <p>PD16 controls the input source, either from external hardware terminals (DI1 ~ DI9) or communication commands(corresponding to Bit 0 ~ 8 of PD25). The bit of PD16 is 1, which means the source is communication DI (PD25), otherwise, the source is hardware terminal DI.</p> <p>If the value read from PD25 is 0x0011, it indicates that DI1 and DI5 are ON.</p> <p>If the value written into PD25 is 0x0011, which means that the communication contacts DI1 and DI5 are ON; but it does not mean that the terminal signals of the digital input DI1 and DI5 are ON, this is determined by PD16 setting value.</p> <p>For the function definition of DI(DI1~DI8), you can refer to PD02~PD09. And you can refer to PD21 for DI9.</p> <p>Example 1</p> <p>If set PD16 to 0FFFh and PD25 to 0000h. the DI1~DI9 all will be controlled by the communication contacts, its digital input contact will all turn OFF. If the external hardware terminals connect all DI1~DI9 to the SG, the digital input signal will not be affected, it will be still controlled by the communication contact and</p>	All	0000h	0000h ~ 01FFh	N/A

		<p>the digital input contact DI1~DI9 will still all OFF.</p> <p>Example 2:</p> <p>The external hardware terminals DI9~DI1 are represented by bit8~bit0 in binary values.</p> <p>Bit8~bit0 indicates DI9~DI1 (from left to right)</p> <p>Digital input contact source control switch (PD16): 111000000</p> <p>The external hardware terminal: 100001111 (1 means ON, 0 means OFF)</p> <p>Communication control digital input contact (PD25): 000111000.</p> <p>In summary,DI9~DI7 (communication address 0x0204) is determined by the communication, and DI6~DI1 is determined by the external hardware terminal. Therefore, the last DI status is 000 001111.</p>				
PD26		Reserved				
PD27	DOD (*)	<p>Definition of output signal contact</p> <p>To define the output contact of output signal DO1~DO5. bit0~bit4 of this parameter shows the contact of DO1~DO5.</p> <p>0 : output contact is normally open(a contact).</p> <p>1 : output contact is normally closed(b contact)</p>	All	0004h	0000h ~ 001F	N/A

PD28	MCOK	<p>Operation option of DO: MC_OK</p> <div style="border: 1px solid black; display: inline-block; padding: 5px; margin: 10px 0;"> <table border="1" style="border-collapse: collapse;"> <tr> <td style="width: 20px; height: 20px; text-align: center;">0</td> <td style="width: 20px; height: 20px; text-align: center;">0</td> <td style="width: 20px; height: 20px; text-align: center;">y</td> <td style="width: 20px; height: 20px; text-align: center;">x</td> </tr> </table> </div> <p>x=0: Output status is not retained, x=1: output status is retained</p> <p>y=0: position deviation alarm AL.1B invalid y=1: position deviation alarm AL.1B valid</p> <p>Diagram</p> <p>1. Command trigger: new Pr command is effective. Command 3 starts and clears signals 2, 4, 5, and 6 simultaneously.</p> <p>2. CMD_OK: indicate if command 3 is complete and it can set the delay time (DLY).</p> <p>3. Command output: output the curve of the position command based on the acceleration / deceleration setting.</p> <p>4. INP: indicates if position error of the servo drive is within the range set in PA12.</p> <p>5. MC_OK: command output and servo positioning is completed, and signal 2&4 are both on.</p> <p>6. MC_OK (retains digital output status): same as 5. Once this digital output is on(7), its status is retained regardless of the signal 4.</p> <p>7. Either signal 5 or signal 6 can be output, and the choice is specified in PD28. X.</p> <p>8. Position deviation: when event 7 occurs, if signal 4 (or 5) is off, it means the position has deviated and AL.1B can be triggered. Set whether to enable this alarm with PD28. y.</p>	0	0	y	x	Pr	0000h	0000h ~ 0011h	N/A
0	0	y	x							

PD29	DID	<p>Software DI A/B contact setting</p> <p>1. The corresponding bit is 0: If DI setting is LSP/LSN/EMG, B contact is open. If DI setting is not LSP/LSN/EMG,A contact is open.</p> <p>2. The corresponding bit is 1: If DI setting is LSP/LSN/EMG, A contact is open. If DI setting is not LSP/LSN/EMG,B contact is open.</p> <p>Note:If any DI is assigned to be controlled by the PC communication software, this application is invalid(Refer to PD16).</p>	All	0000h	0000h ~ 01FFh	N/A
PD30 ~ PD31		Reserved				
PD32	SDLY (*)	<p>Servo ON delay time</p> <p>To set the delay time when Servo ON is activated.</p>	All	0	0 ~ 3000	msec
PD33	SFDO	<p>Software DO register</p> <p>Bit0~bit7 of this setting controls the S_DO0~S_DO7 of DO signal separately.</p>	All	0000h	0000h ~ 00FFh	N/A
PD34 ~ PD40		Reserved.				

No	Abbr.	Parameter function and description	mode	Default	Range	Unit														
PE01	PDEF1	<p>Definition of homing</p> <p>The detailed parameters are defined as follows:</p> <table border="1" style="width: 100%; border-collapse: collapse;"> <tr> <td style="width: 12.5%;">31~28</td> <td style="width: 12.5%;">27~24</td> <td style="width: 12.5%;">23~20</td> <td style="width: 12.5%;">19~16</td> <td style="width: 12.5%;">15~12</td> <td style="width: 12.5%;">11~8</td> <td style="width: 12.5%;">7~0 bit</td> </tr> <tr> <td>BOOT</td> <td>-</td> <td>DLY</td> <td>-</td> <td>DEC1</td> <td>ACC</td> <td>PATH</td> </tr> </table> <ul style="list-style-type: none"> ● PATH:path type(bit0~bit7) 0: Stop: homing complete and stop 1~63:Auto: homing complete and execute the specified path. ● ACC:select acceleration time 0 - F , which is correspond to PF49~PF64. DEC1: deceleration time selection for first homing, DEC setting is 0~F, which is correspond to PF49~PF64. DLY: delay time selection,DLY setting is 0~F, which is correspond to PF65~PF80. ● BOOT:when the drive is powered on, whether to search for the origin 0: do not execute homing. 1: execute homing automatically (servo on for the first time after power on). ● Apart from the above definitions, the related settings for homing also include: <ol style="list-style-type: none"> 1. PA04 homing mode. 2. PA08~PA09 speed setting of searching for the origin. 3. PE02: ORG_DEF is the coordinate of the origin and may not be 0. This function is used as a traversal of the coordinate. <p>A. SDC does not provide the SDA origin stop function to set whether to return to the origin after homing,this should operate by another method. After the origin (sensor or Z) is found, the servo has to decelerate to stop. The stop position exceeds the origin with a short distance: If returning to the origin is not needed, set PATH to 0. If returning to the origin is needed, set PATH to a non-zero value and set PABS = ORG_DEF.</p> <p>B. If the origin is found (sensor or Z), and you want the servo to move an offset S and define the coordinate as P after moving, then PATH = non-zero and set ORG_DEF = P - S, and this absolute Position command = P.</p>	31~28	27~24	23~20	19~16	15~12	11~8	7~0 bit	BOOT	-	DLY	-	DEC1	ACC	PATH	Pr	000000 00h	00000000h ~ 10FFFF3Fh	N/A
31~28	27~24	23~20	19~16	15~12	11~8	7~0 bit														
BOOT	-	DLY	-	DEC1	ACC	PATH														

PE02	PDEF1	Origin offset value definition <table border="1" style="margin-left: 20px;"> <tr> <td style="padding: 2px;">31~16</td> <td style="padding: 2px;">15~0 bit</td> </tr> <tr> <td colspan="2" style="padding: 2px; text-align: center;">ORG_DEF(32bit)</td> </tr> </table>	31~16	15~0 bit	ORG_DEF(32bit)		Pr	0	(-2 ³¹ +1) ~ (2 ³¹ -1)	N/A
31~16	15~0 bit									
ORG_DEF(32bit)										
PE03	PDEF1	PATH#1 definition The detailed parameters are defined as follows You can refer to Chapter 7 for detailed operation instructions of PR.	Pr	000000 00h	000000 00h ~ FFFFFF FFFh	N/A				

	31~28	27~24	23~20	19~16	15~12	11~8	7~4	3~0 bit
PE03	-	-	DLY	-	-	-	OPT	TYPE
PE04	DATA(32bit)							

- TYPE, OPT

OPT option				Path TYPE
7	6	5	4 BIT	3~0 BIT
-	UNIT	AUTO	INS	1: SPEED, constant speed control.
CMD		OVLP	INS	2: SINGLE positioning control. It stops when finished. 3: AUTO positioning control. It automatically loads the next path when finished
-	-	-	INS	7: JUMP, jump to the specified path.
-	-	AUTO	INS	8: write specified parameter to specified path.

- TYPE: when 1, 2, or 3 is executed, it can be interrupted and stopped by DO: STP and software limits.
- INS: if INS is set, it can interrupt the previous program and execute this program!
- OVLP: allow overlapping of the next path. Overlapping is not allowed in Speed mode. When overlapping in position mode, DLY is invalid.
- AUTO: executing the next PR path when the current PR completes
- CMD: refer to Chapter 7 PR command instruction.
- DLY: 0 ~ F can use as the delay time number (4 BIT). It is the delay time after the execution of this path. The external INS is invalid! (DLY related parameters: PF65~PF80).

No	Abbr.	Parameter function and description	mode	Default	Range	Unit
PE04	PDAT1	<p>PATH#1 data</p> <p>PE03 defines the property of the target point; PE04 defines the target position of PE03 or the target PATH_NO for the Jump. command.</p> <p>Note: PATH: Program</p>	Pr	0	<p>using non-index positioning function</p> <p>$(-2^{31}) \sim (2^{31}-1)$</p> <p>using index positioning function</p> <p>(0~4194304)</p>	N/A
PE05	PDEF2	<p>PATH#2 definition</p> <p>Refer to description of PE03.</p>	Pr	00000000h	00000000h~FFFFFFFh	N/A
PE06	PDAT2	<p>PATH#2 data</p> <p>Refer to description of PE04.</p>	Pr	0	$(-2^{31}+1) \sim (2^{31}-1)$	N/A
PE07	PDEF3	<p>PATH#3 definition</p> <p>Refer to description of PE03.</p>	Pr	00000000h	00000000h~FFFFFFFh	N/A
PE08	PDAT3	<p>PATH#3 data</p> <p>Refer to description of PE04.</p>	Pr	0	$(-2^{31}+1) \sim (2^{31}-1)$	N/A
PE09	PDEF4	<p>PATH#4 definition</p> <p>Refer to description of PE03.</p>	Pr	00000000h	00000000h~FFFFFFFh	N/A
No	Abbr.	Parameter function and description	mode	Default	Range	Unit

PE10	PDAT4	PATH#4 data Refer to description of PE04.	Pr	0	$(-2^{31}+1) \sim (2^{31}-1)$	N/A
PE11	PDEF5	PATH#5 definition Refer to description of PE03.	Pr	000000 00h	0000000 0h~FFFF FFFFh	N/A
PE12	PDAT5	PATH#5 data Refer to description of PE04.	Pr	0	$(-2^{31}+1) \sim (2^{31}-1)$	N/A
PE13	PDEF6	PATH#6 definition Refer to description of PE03.	Pr	000000 00h	0000000 0h~FFFF FFFFh	N/A
PE14	PDAT6	PATH#6 data Refer to description of PE04.	Pr	0	$(-2^{31}+1) \sim (2^{31}-1)$	N/A
PE15	PDEF7	PATH#7 definition Refer to description of PE03.	Pr	000000 00h	0000000 0h~FFFF FFFFh	N/A
PE16	PDAT7	PATH#7 data Refer to description of PE04.	Pr	0	$(-2^{31}+1) \sim (2^{31}-1)$	N/A
PE17	PDEF8	PATH#8 definition Refer to description of PE03.	Pr	000000 00h	0000000 0h~FFFF FFFFh	N/A
PE18	PDAT8	PATH#8 data Refer to description of PE04.	Pr	0	$(-2^{31}+1) \sim (2^{31}-1)$	N/A
PE19	PDEF9	PATH#9 definition Refer to description of PE03.	Pr	000000 00h	0000000 0h~FFFF FFFFh	N/A
PE20	PDAT9	PATH#9 data Refer to description of PE04.	Pr	0	$(-2^{31}+1) \sim (2^{31}-1)$	N/A
PE21	PDEF10	PATH#10 definition Refer to description of PE03.	Pr	000000 00h	0000000 0h~FFFF	N/A

					FFFFh	
PE22	PDAT10	PATH#10 data Refer to description of PE04.	Pr	0	$(-2^{31}+1) \sim (2^{31}-1)$	N/A
PE23	PDEF11	PATH#11 definition Refer to description of PE03.	Pr	000000 00h	0000000 0h~FFFF FFFFh	N/A
PE24	PDAT11	PATH#11 data Refer to description of PE04.	Pr	0	$(-2^{31}+1) \sim (2^{31}-1)$	N/A
PE25	PDEF12	PATH#12 definition Refer to description of PE03.	Pr	000000 00h	0000000 0h~FFFF FFFFh	N/A
PE26	PDAT12	PATH#12 data Refer to description of PE04.	Pr	0	$(-2^{31}+1) \sim (2^{31}-1)$	N/A
PE27	PDEF13	PATH#13 definition Refer to description of PE03.	Pr	000000 00h	0000000 0h~FFFF FFFFh	N/A
PE28	PDAT13	PATH#13 data Refer to description of PE04.	Pr	0	$(-2^{31}+1) \sim (2^{31}-1)$	N/A
PE29	PDEF14	PATH#14 definition Refer to description of PE03.	Pr	000000 00h	0000000 0h~FFFF FFFFh	N/A
PE30	PDAT14	PATH#14 data Refer to description of PE04.	Pr	0	$(-2^{31}+1) \sim (2^{31}-1)$	N/A
PE31	PDEF15	PATH#15 definition Refer to description of PE03.	Pr	000000 00h	0000000 0h~FFFF FFFFh	N/A
PE32	PDAT15	PATH#15 data Refer to description of PE04.	Pr	0	$(-2^{31}+1) \sim (2^{31}-1)$	N/A
PE33	PDEF16	PATH#16 definition Refer to description of PE03.	Pr	000000 00h	0000000 h~FFFFFF FFFh	N/A
PE34	PDAT16	PATH#16 data Refer to description of PE04.	Pr	0	$(-2^{31}+1) \sim (2^{31}-1)$	N/A

PE35	PDEF17	PATH#17 definition Refer to description of PE03.	Pr	000000 00h	00000000 h~FFFFFF FFFh	N/A
PE36	PDAT17	PATH#17 data Refer to description of PE04.	Pr	0	$(-2^{31}+1) \sim$ $(2^{31}-1)$	N/A
PE37	PDEF18	PATH#18 definition Refer to description of PE03.	Pr	000000 00h	00000000 h~FFFFFF FFFh	N/A
PE38	PDAT18	PATH#18 data Refer to description of PE04.	Pr	0	$(-2^{31}+1) \sim$ $(2^{31}-1)$	N/A
PE39	PDEF19	PATH#19 definition Refer to description of PE03.	Pr	000000 00h	00000000 h~FFFFFF FFFh	N/A
PE40	PDAT19	PATH#19 data Refer to description of PE04.	Pr	0	$(-2^{31}+1) \sim$ $(2^{31}-1)$	N/A
PE41	PDEF20	PATH#20 definition Refer to description of PE03.	Pr	000000 00h	00000000 h~FFFFFF FFFh	N/A
PE42	PDAT20	PATH#20 data Refer to description of PE04.	Pr	0	$(-2^{31}+1) \sim$ $(2^{31}-1)$	N/A
PE43	PDEF21	PATH#21 definition Refer to description of PE03.	Pr	000000 00h	00000000 h~FFFFFF FFFh	N/A
PE44	PDAT21	PATH#21 data Refer to description of PE04.	Pr	0	$(-2^{31}+1) \sim$ $(2^{31}-1)$	N/A
PE45	PDEF22	PATH#22 definition Refer to description of PE03.	Pr	000000 00h	00000000 h~FFFFFF FFFh	N/A

PE46	PDAT22	PATH#22 data Refer to description of PE04.	Pr	0	$(-2^{31}+1) \sim (2^{31}-1)$	N/A
PE47	PDEF23	PATH#23 definition Refer to description of PE03.	Pr	000000 00h	00000000 h~FFFFFF FFFh	N/A
PE48	PDAT23	PATH#23 data Refer to description of PE04.	Pr	0	$(-2^{31}+1) \sim (2^{31}-1)$	N/A
PE49	PDEF24	PATH#24 definition Refer to description of PE03.	Pr	000000 00h	00000000 h~FFFFFF FFFh	N/A
PE50	PDAT24	PATH#24 data Refer to description of PE04.	Pr	0	$(-2^{31}+1) \sim (2^{31}-1)$	N/A
PE51	PDEF25	PATH#25 definition Refer to description of PE03.	Pr	000000 00h	00000000 h~FFFFFF FFFh	N/A
PE52	PDAT25	PATH#25 data Refer to description of PE04.	Pr	0	$(-2^{31}+1) \sim (2^{31}-1)$	N/A
PE53	PDEF26	PATH#26 definition Refer to description of PE03.	Pr	000000 00h	00000000 h~FFFFFF FFFh	N/A
PE54	PDAT26	PATH#26 data Refer to description of PE04.	Pr	0	$(-2^{31}+1) \sim (2^{31}-1)$	N/A
PE55	PDEF27	PATH#27 definition Refer to description of PE03.	Pr	000000 00h	00000000 h~FFFFFF FFFh	N/A
PE56	PDAT27	PATH#27 data Refer to description of PE04.	Pr	0	$(-2^{31}+1) \sim (2^{31}-1)$	N/A

PE57	PDEF28	PATH#28 definition Refer to description of PE03.	Pr	000000 00h	00000000 h~FFFFFF FFFh	N/A
PE58	PDAT28	PATH#28 data Refer to description of PE04.	Pr	0	$(-2^{31}+1) \sim$ $(2^{31}-1)$	N/A
PE59	PDEF29	PATH#29 definition Refer to description of PE03.	Pr	000000 00h	00000000 h~FFFFFF FFFh	N/A
PE60	PDAT29	PATH#29 data Refer to description of PE04.	Pr	0	$(-2^{31}+1) \sim$ $(2^{31}-1)$	N/A
PE61	PDEF30	PATH#30 definition Refer to description of PE03.	Pr	000000 00h	00000000 h~FFFFFF FFFh	N/A
PE62	PDAT30	PATH#30 data Refer to description of PE04.	Pr	0	$(-2^{31}+1) \sim$ $(2^{31}-1)$	N/A
PE63	PDEF31	PATH#31 definition Refer to description of PE03.	Pr	000000 00h	00000000 0h~FFFF FFFFh	N/A
PE64	PDAT31	PATH#31 data Refer to description of PE04.	Pr	0	$(-2^{31}+1) \sim$ $(2^{31}-1)$	N/A
PE65	PDEF32	PATH#32 definition Refer to description of PE03.	Pr	000000 00h	00000000h ~FFFFFFF Fh	N/A
PE66	PDAT32	PATH#32 data Refer to description of PE04.	Pr	0	$(-2^{31}+1) \sim$ $(2^{31}-1)$	N/A
PE67	PDEF33	PATH#33 definition Refer to description of PE03.	Pr	000000 00h	00000000 h~FFFFFF FFFh	N/A

PE68	PDAT33	PATH#33 data Refer to description of PE04.	Pr	0	$(-2^{31}+1) \sim (2^{31}-1)$	N/A
PE69	PDEF34	PATH#34 definition Refer to description of PE03.	Pr	000000 00h	00000000 h~FFFFFF FFFh	N/A
PE70	PDAT34	PATH#34 data Refer to description of PE04.	Pr	0	$(-2^{31}+1) \sim (2^{31}-1)$	N/A
PE71	PDEF35	PATH#35 definition Refer to description of PE03.	Pr	000000 00h	00000000 h~FFFFFF FFFh	N/A
PE72	PDAT35	PATH#35 data Refer to description of PE04.	Pr	0	$(-2^{31}+1) \sim (2^{31}-1)$	N/A
PE73	PDEF36	PATH#36 definition Refer to description of PE03.	Pr	000000 00h	00000000 h~FFFFFF FFFh	N/A
PE74	PDAT36	PATH#36 data Refer to description of PE04.	Pr	0	$(-2^{31}+1) \sim (2^{31}-1)$	N/A
PE75	PDEF37	PATH#37 definition Refer to description of PE03.	Pr	000000 00h	00000000 h~FFFFFF FFFh	N/A
PE76	PDAT37	PATH#37 data Refer to description of PE04.	Pr	0	$(-2^{31}+1) \sim (2^{31}-1)$	N/A
PE77	PDEF38	PATH#38 definition Refer to description of PE03.	Pr	000000 00h	00000000 h~FFFFFF FFFh	N/A
PE78	PDAT38	PATH#38 data Refer to description of PE04.	Pr	0	$(-2^{31}+1) \sim (2^{31}-1)$	N/A

PE79	PDEF39	PATH#39 definition Refer to description of PE03.	Pr	000000 00h	00000000 h~FFFFFF FFFh	N/A
PE80	PDAT39	PATH#39 data Refer to description of PE04.	Pr	0	$(-2^{31}+1) \sim$ $(2^{31}-1)$	N/A
PE81	PDEF40	PATH#40 definition Refer to description of PE03.	Pr	000000 00h	00000000 h~FFFFFF FFFh	N/A
PE82	PDAT40	PATH#40 data Refer to description of PE04.	Pr	0	$(-2^{31}+1) \sim$ $(2^{31}-1)$	N/A
PE83	PDEF41	PATH#41 definition Refer to description of PE03.	Pr	000000 00h	00000000 h~FFFFFF FFFh	N/A
PE84	PDAT41	PATH#41 data Refer to description of PE04.	Pr	0	$(-2^{31}+1) \sim$ $(2^{31}-1)$	N/A
PE85	PDEF42	PATH#42 definition Refer to description of PE03.	Pr	000000 00h	00000000 h~FFFFFF FFFh	N/A
PE86	PDAT42	PATH#42 data Refer to description of PE04.	Pr	0	$(-2^{31}+1) \sim$ $(2^{31}-1)$	N/A
PE87	PDEF43	PATH#43 definition Refer to description of PE03.	Pr	000000 00h	00000000 h~FFFFFF FFFh	N/A
PE88	PDAT43	PATH#43 data Refer to description of PE04.	Pr	0	$(-2^{31}+1) \sim$ $(2^{31}-1)$	N/A
PE89	PDEF44	PATH#44 definition Refer to description of PE03.	Pr	000000 00h	00000000 h~FFFFFF FFFh	N/A

PE90	PDAT44	PATH#44 data Refer to description of PE04.	Pr	0	$(-2^{31}+1) \sim (2^{31}-1)$	N/A
PE91	PDEF45	PATH#45 definition Refer to description of PE03.	Pr	000000 00h	00000000 h~FFFFFF FFFh	N/A
PE92	PDAT45	PATH#45 data Refer to description of PE04.	Pr	0	$(-2^{31}+1) \sim (2^{31}-1)$	N/A



No	Abbr.	Parameter function and description	mode	Default	Range	Unit
PF01	PDEF49	PATH#49 definition Refer to description of PE03.	Pr	000000 00h	00000000h ~FFFFFFFh	N/A
PF02	PDAT49	PATH#49 data Refer to description of PE04.	Pr	0	$(-2^{31}+1) \sim (2^{31}-1)$	N/A
PF03	PDEF50	PATH#50 definition Refer to description of PE03.	Pr	000000 00h	00000000h ~FFFFFFFh	N/A
PF04	PDAT50	PATH#50 data Refer to description of PE04.	Pr	0	$(-2^{31}+1) \sim (2^{31}-1)$	N/A
PF05	PDEF51	PATH#51 definition Refer to description of PE03.	Pr	000000 00h	00000000h ~FFFFFFFh	N/A
PF06	PDAT51	PATH#51 data Refer to description of PE04.	Pr	0	$(-2^{31}+1) \sim (2^{31}-1)$	N/A
PF07	PDEF52	PATH#52 definition Refer to description of PE03.	Pr	000000 00h	00000000h ~FFFFFFFh	N/A
PF08	PDAT52	PATH#52 data Refer to description of PE04.	Pr	0	$(-2^{31}+1) \sim (2^{31}-1)$	N/A
PF09	PDEF53	PATH#53 definition Refer to description of PE03.	Pr	000000 00h	00000000h ~FFFFFFFh	N/A
PF10	PDAT53	PATH#53 data Refer to description of PE04.	Pr	0	$(-2^{31}+1) \sim (2^{31}-1)$	N/A
PF11	PDEF54	PATH#54 definition Refer to description of PE03.	Pr	000000 00h	00000000h ~FFFFFFFh	N/A
PF12	PDAT54	PATH#54 data Refer to description of PE04.	Pr	0	$(-2^{31}+1) \sim (2^{31}-1)$	N/A
PF13	PDEF55	PATH#55 definition Refer to description of PE03.	Pr	000000 00h	00000000h ~FFFFFFFh	N/A

PF14	PDAT55	PATH#55 data Refer to description of PE04.	Pr	0	$(-2^{31}+1) \sim (2^{31}-1)$	N/A
PF15	PDEF56	PATH#56 definition Refer to description of PE03.	Pr	000000 00h	00000000h ~FFFFFFFF Fh	N/A
PF16	PDAT56	PATH#56 data Refer to description of PE04.	Pr	0	$(-2^{31}+1) \sim (2^{31}-1)$	N/A
PF17	PDEF57	PATH#57 definition Refer to description of PE03.	Pr	000000 00h	00000000h ~FFFFFFFF Fh	N/A
PF18	PDAT57	PATH#57 data Refer to description of PE04.	Pr	0	$(-2^{31}+1) \sim (2^{31}-1)$	N/A
PF19	PDEF58	PATH#58 definition Refer to description of PE03.	Pr	000000 00h	00000000h ~FFFFFFFF Fh	N/A
PF20	PDAT58	PATH#58 data Refer to description of PE04.	Pr	0	$(-2^{31}+1) \sim (2^{31}-1)$	N/A
PF21	PDEF59	PATH#59 definition Refer to description of PE03.	Pr	000000 00h	00000000h ~FFFFFFFF Fh	N/A
PF22	PDAT59	PATH#59 data Refer to description of PE04.	Pr	0	$(-2^{31}+1) \sim (2^{31}-1)$	N/A
PF23	PDEF60	PATH#60 definition Refer to description of PE03.	Pr	000000 00h	00000000h ~FFFFFFFF Fh	N/A
PF24	PDAT60	PATH#60 data Refer to description of PE04.	Pr	0	$(-2^{31}+1) \sim (2^{31}-1)$	N/A
PF25	PDEF61	PATH#61 definition Refer to description of PE03.	Pr	000000 00h	00000000h ~FFFFFFFF Fh	N/A
PF26	PDAT61	PATH#61 data Refer to description of PE04.	Pr	0	$(-2^{31}+1) \sim (2^{31}-1)$	N/A
PF27	PDEF62	PATH#62 definition Refer to description of PE03.	Pr	000000 00h	00000000h ~FFFFFFFF Fh	N/A
PF28	PDAT62	PATH#62 data Refer to description of PE04.	Pr	0	$(-2^{31}+1) \sim (2^{31}-1)$	N/A

PF29	PDEF63	PATH#63 definition Refer to description of PE03.	Pr	000000 00h	00000000h ~FFFFFFFh	N/A
PF30	PDAT63	PATH#63 data Refer to description of PE04.	Pr	0	$(-2^{31}+1) \sim (2^{31}-1)$	N/A
PF31		Reserved				
PF32		Reserved				

No	Abbr.	Parameter function and description	mode	Default	Range	Unit
PF33	POV1	Speed setting of internal position command 1	Pr	50	1~6000	rpm
PF34	POV2	Speed setting of internal position command 2	Pr	10	1~6000	rpm
PF35	POV3	Speed setting of internal position command 3	Pr	200	1~6000	rpm
PF36	POV4	Speed setting of internal position command 4	Pr	300	1~6000	rpm
PF37	POV5	Speed setting of internal position command 5	Pr	500	1~6000	rpm
PF38	POV6	Speed setting of internal position command 6	Pr	800	1~6000	rpm
PF39	POV7	Speed setting of internal position command 7	Pr	1000	1~6000	rpm
PF40	POV8	Speed setting of internal position command 8	Pr	1200	1~6000	rpm
PF41	POV9	Speed setting of internal position command 9	Pr	1500	1~6000	rpm
PF42	POV10	Speed setting of internal position command 10	Pr	1800	1~6000	rpm
PF43	POV11	Speed setting of internal position command 11	Pr	2000	1~6000	rpm
PF44	POV12	Speed setting of internal position command 12	Pr	2200	1~6000	rpm
PF45	POV13	Speed setting of internal position command 13	Pr	2400	1~6000	rpm

PF46	POV14	Speed setting of internal position command 14	Pr	2700	1~6000	rpm
PF47	POV15	Speed setting of internal position command 15	Pr	3000	1~6000	rpm
PF48	POV16	Speed setting of internal position command 16	Pr	3000	1~6000	rpm
PF49	POA1	Acceleration/deceleration time of internal position command 1 To set the accelerate/decelerate time in Pr mode, that is time needed from 0 to motor rated speed.	Pr	200	1~65550	ms
PF50	POA2	Acceleration/deceleration time of internal position command 2 Refer to description of PF49.	Pr	200	1~65550	ms
PF51	POA3	Acceleration/deceleration time of internal position command 3 Refer to description of PF49.	Pr	300	1~65550	ms
PF52	POA4	Acceleration/deceleration time of internal position command 4 Refer to description of PF49.	Pr	500	1~65550	ms

No	Abbr.	Parameter function and description	mode	Default	Range	Unit
PF53	POV5	Acceleration/deceleration time of internal position command 6 Refer to description of PF49.	Pr	600	1~65550	ms
PF54	POV6	Acceleration/deceleration time of internal position command 6 Refer to description of PF49.	Pr	800	1~65550	ms
PF55	POV7	Acceleration/deceleration time of internal position command 7 Refer to description of PF49.	Pr	900	1~65550	ms
PF56	POV8	Acceleration/deceleration time of internal position command 8 Refer to description of PF49.	Pr	1000	1~65550	ms
PF57	POV9	Acceleration/deceleration time of internal position command 9 Refer to description of PF49.	Pr	1200	1~65550	ms
PF58	POV10	Acceleration/deceleration time of internal position command 10 Refer to description of PF49.	Pr	1400	1~65550	ms
PF59	POV11	Acceleration/deceleration time of internal position command 11 Refer to description of PF49.	Pr	1600	1~65550	ms
PF60	POV12	Acceleration/deceleration time of internal position command 12 Refer to description of PF49.	Pr	2000	1~65550	ms
PF61	POV13	Acceleration/deceleration time of internal position command 13	Pr	2500	1~65550	ms

		Refer to description of PF49.				
PF62	POV14	Acceleration/deceleration time of internal position command 14 Refer to description of PF49.	Pr	3000	1~65550	ms
PF63	POV15	Acceleration/deceleration time of internal position command 15 Refer to description of PF49.	Pr	4000	1~65550	ms
PF64	POV16	Acceleration/deceleration time of internal position command 16 Refer to description of PF49.	Pr	5000	1~65550	ms
PF65	DLY1	Delay time after internal position 1 completion To set the delay time in Pr mode.	Pr	0	0~32767	ms
PF66	DLY2	Delay time after internal position 2 completion Refer to description of PF65.	Pr	100	0~32767	ms
PF67	DLY3	Delay time after internal position 3 completion Refer to description of PF65.	Pr	200	0~32767	ms
PF68	DLY4	Delay time after internal position 4 completion Refer to description of PF65.	Pr	300	0~32767	ms
PF69	DLY5	Delay time after internal position 5 completion Refer to description of PF65.	Pr	500	0~32767	ms
PF70	DLY6	Delay time after internal position 6 completion Refer to description of PF65.	Pr	600	0~32767	ms
PF71	DLY7	Delay time after internal position 7 completion Refer to description of PF65.	Pr	800	0~32767	ms
PF72	DLY8	Delay time after internal position 8 completion Refer to description of PF65.	Pr	1000	0~32767	ms

PF73	DLY9	Delay time after internal position 9 completion Refer to description of PF65.	Pr	1200	0~32767	ms
PF74	DLY10	Delay time after internal position 10 completion Refer to description of PF65.	Pr	1500	0~32767	ms
PF75	DLY11	Delay time after internal position 11 completion Refer to description of PF65.	Pr	2000	0~32767	ms
PF76	DLY12	Delay time after internal position 12 completion Refer to description of PF65.	Pr	2300	0~32767	ms
PF77	DLY13	Delay time after internal position 13 completion Refer to description of PF65.	Pr	2500	0~32767	ms
PF78	DLY14	Delay time after internal position 14 completion Refer to description of PF65.	Pr	3000	0~32767	ms
PF79	DLY15	Delay time after internal position 15 completion Refer to description of PF65.	Pr	4000	0~32767	ms
PF80	DLY16	Delay time after internal position 16 completion Refer to description of PF65.	Pr	5000	0~32767	ms
PF81	PDEC	Deceleration time for auto-protection	All	000000 00h	0~~ F0F0FFFF h	N/A

The parameter setting is divided into D, C, B, A, W, Z, Y, and X (hexadecimal), including:

1. Deceleration time when the auto-protection function is enabled

Digit	D	C	B	A	W	Z	Y	X
function	STP	Reserved	CTO	Reserved	SNL	SPL	NL	PL
Range	0~F	-	0~F	-	0~F	0~F	0~F	0~F

2. the meaning of the code is as follows

STP : The second deceleration time of homing, DI STOP deceleration time

CTO : The deceleration time when communication timeout or ABS communication alarm occurs.

SNL : The deceleration time when the software negative limit alarm occurs.

SPL :The deceleration time when the software positive limit alarm occurs.

NL : The deceleration time when the LSN reverse limit alarm occurs.

PL : The deceleration time when the LSP positive limit alarm occurs.

0~F is used to index the deceleration time of PF49~PF64

For example, if X is set to A, the deceleration time of PL is determined by the content of PF58.

PF82	PRCM	Pr command trigger register	Pr	0	0~~1000	N/A
------	------	-----------------------------	----	---	---------	-----

(■)

Set PF82 to 0 to start homing

Set PF82 to 1~63 to execute the specified PR procedure, which is the same as using DI:CTRG+POS_n.

You cannot set PF82 to 64 ~ 9999 as it's write-inhibit(the value exceeds the valid range).

Write 1000 to execute stop command which is the same as DI:STOP.

When reading PF82, if the command is incomplete, the drive reads the current command. If the command is complete, the drive reads the current command +10000. If the command is complete, DO. TPOS is on, and motor position is reached, the drive reads the current command +20000. Commands triggered by DI are also applicable.

Example: If set the position command as 3, it triggers PR#3. If the value read is 3, it means PR#3 is executing and not complete yet. If the value read is 10003, it means PR#3 command completed, but the motor has not reached the target position yet. If the value read is 20003, it means PR#3 completed and the motor reached the target position.

No	Abbr.	Parameter function and description	mode	Default	Range	Unit
PF83	EVON	PR number triggered by event rising edge	Pr	0000h	0000h~ DDDDh	N/A
		Parameter function: 4 digits: UZYX PR number executed when EVx is ON. X=0:no action when EV1 is ON. X=1~D:execute PR# 51~63 when EV1 is ON. Y=0:no action when EV2 is ON. Y=1~D:execute PR# 51~63 when EV2 is ON. Z=0:no action when EV3 is ON. Z=1~D:execute PR# 51~63 when EV3 is ON. U=0:no action when EV4 is ON. U=1~D:execute PR# 51~63 when EV4 is ON.				
PF84	EVOF	PR number triggered by event falling-edge	Pr	0000h	0000h~ DDDDh	N/A
		Parameter function: 4 digits: UZYX. PR number executed when EVx is OFF. X=0: no action when EV1 is OFF. X=1~D: execute PR# 51~63 when EV1 is OFF. Y=0: no action when EV2 is OFF. Y=1~D:execute PR# 51~63 when EV2 is OFF. Z=0: no action when EV3 is OFF. Z=1~D: execute PR# 51~63 when EV3 is OFF				

		<p>U=0: no action when EV4 is OFF.</p> <p>U=1~D: execute PR# 51~63 when EV4 is OFF.</p>				
PF85	PMEM	<p>PATH#1 to PATH#2 memory invalid</p> <p>Parameter function: 4 digits: UZYX:</p> <p>X=0:PATH#1 data is hold when drive is power off</p> <p>X=1:PATH#1 data is not hold when drive is power off</p> <p>Y=0:PATH#2 data is hold when drive is power off</p> <p>Y=1:PATH#2 data is not hold when drive is power off</p> <p>The others reserved</p> <p>This parameter mainly allows users to write new target points continuously through communication.</p>	All	0000h	0000h ~ 0011h	N/A

No	Abbr.	Parameter function and description	mode	Default	Range	Unit
PF86	SWLP	Positive software limit In Pr mode, if the motor moves in the positive direction and its feedback position exceeds the value of PF86, AL.14 will occur. Note: The position command mentioned above is before the electronic gear ratio.	Pr	$2^{31}-1$	$-2^{31}+1$ ~ $2^{31}-1$	pulse
PF87	SWLN	Negative software limit In Pr mode, if the motor moves in the negative direction and its feedback position exceeds the value of PF87, AL.15 occurs. Note: The position command mentioned above is before the electronic gear ratio.	Pr	$-2^{31}+1$	$-2^{31}+1$ ~ $2^{31}-1$	pulse
PF88		Reserved				
PF89 (*)	BLSF	Backlash compensation option Setting value: 0:disable. 1:forward direction compensation . 2:reverse direction compensation.	Pr. Pt	0	0 ~ 2	N/A
PF90	BLSP	Setting of backlash compensation function (before electronic gear ratio)	Pr. Pt	0	-32767 ~ 32767	pulse
PF91	BLST	Backlash compensation time constant setting	Pr. Pt	0	0 ~ 10000	0. 1ms
PF92 ~ PF99		Reserved				

Table 8.1: Digital input(DI) function description:

Sign	Setting	DI function description
SON	0x01	When this DI is on, servo will be activated.
RES	0x02	When alarm occurs, some alarm will be cleared if RES is ON.
PC	0x03	When PC is ON, it will switch the speed controller from proportional integral type to proportional type.
TL	0x04	N/A
TL1	0x05	Internal torque limit 2 is valid when TL1 is on.
SP1	0x06	Speed command option 1 in speed mode.
SP2	0x07	Speed command option 2 in speed mode.
SP3	0x08	Speed command option 3 in speed mode.
ST1/RS2	0x09	In speed mode, when ST1/RS2 is ON, the servo runs in forward rotation. In torque mode, when ST1/RS2 is ON, the servo runs in reverse rotation.
ST2/RS1	0x0A	In speed mode, when ST2/RS1 is ON, the motor runs in reverse rotation. In torque mode, when ST2/RS1 is ON, the motor runs in forward rotation.
ORGP	0x0B	In internal register position mode, when searching for the origin, the servo will take the position of this point as the origin after ORGP is turned on.
SHOM	0x0C	In the internal position register mode, when this DI is on, it will activate the function to search for the origin.
CM1	0x0D	Electronic gear option 1 (position mode)
CM2	0x0E	Electronic gear option 2 (position mode)
CR	0x0F	When CR is on, the position control pulse errors will be cleared at the rising positive edge. Pulse width should be above 10ms.
CDP	0x10	Turn CDP on to change the gain values into the multiplier of parameter.
LOP	0x11	In dual mode, turn LOP1 on to switch between different control modes
EMG	0x12	When this EMG is OFF, the servo will be in an emergency state, When EMG is ON, the emergency will be released
POS1	0x13	Position command option 1 in internal register position mode
POS2	0x14	Position command option 2 in internal register position mode
POS3	0x15	Position command option 3 in internal register position mode
CTRG	0x16	In Pr mode, the motor will run according to the command issued by the register when this DI is on.
LSP	0x18	To use as switch of forward rotation limit. When LSP is on, the motor will be operate

		forwardly.
LSN	0x19	To use as switch of reverse rotation limit. When LSN is on, the motor will be operate reversely.
POS4	0x1A	Position command option 4 in internal register position mode
POS5	0x1B	Position command option 5 in internal register position mode
POS6	0x1C	Position command option 6 in internal register position mode
INHP	0x1D	Turn INHP on to enable inhabit pulse input function.
EV1	0x1E	Turn EV1 on to enable Event trigger Pr command 1.
EV2	0x1F	Turn EV2 on to enable Event trigger Pr command 2.
EV3	0x20	Turn EV3 on to enable Event trigger Pr command 3.
EV4	0x21	Turn EV4 on to enable Event trigger Pr command 4.
ABSE	0x22	Turn ABSE on to enable Delta ABS transmission mode.
ABSC	0x23	Turn SBSC on to enable Delta/Mitsubishi origin setting.
ABSM	0x22	Turn ABSM on to enable Delta ABS transmission mode
STOP	0x24	In the internal position register mode, when STOP is ON, the motor will stop.
TC1	0x2D	Torque command option 1.
TC2	0x2E	Torque command option 2.
Pt-Pr	0x2F	Switch between Pt and Pr.

Table 8.2: Digital output(DO) function description.

Sign	Setting	Digital output(DO) function description.
RD	0x01	RD-SG is conductive if servo is ON.
ALM	0x02	ALM-SG is not conductive if the power supply is OFF or the protection circuit is activated which will disconnect the main circuit. ALM-SG is conductive one second after the power is turned on if there is no alarm.
INP/SA	0x03	In the position mode, INP-SG is conductive if position errors is within the setting range. In the speed mode, SA-SG is conductive if motor speed is close to the setting range.
HOME	0x04	HOME signal is on after the completion of homing.
TLC/	0x05	In position and speed control mode, TLC-SG is conductive if motor torque reaches

VLC		internal torque limit. TLC-SG is not conductive when SON is OFF. In torque control mode, VLC-SG is conductive when the motor reaches the speed limit with internal speed command 1~7. VLC-SG is not conductive when SON signal is OFF.
MBR	0x06	When using this signal, PA01 need to be set to □1□□, MBR-SG is not conductive when servo is off or any alarm occurs. When alarm occurs, the main circuit is connecting.
WNG	0x07	Using WNG signal to assign the pin function. The receiving signal cannot be used before setting. WNG-SG is conductive when alarm occurs. If no alarm occurs, WNG-SG is not conductive after turning power on 1 second.
ZSP	0x08	ZSP-SG is conductive when servo motor speed is below zero speed.
CMDOK	0x09	Signal CMDOK is on when internal position command completed or stopped.
OLW	0x0A	OLW is on when overload setting level (PA17) is reached.
MC_OK	0x0B	MC_OK is ON when both CMDOK and INP are ON. Otherwise, MC_OK is OFF.
OVF	0x0C	OVF is ON when motor position command pulse is over $2^{31}-1$ or less than -2^{31} . Otherwise, OVF is off.
SWPL	0x0D	SWPL is on when position command is great than software positive limit(PF86), Otherwise, SWPL is OFF.
SWNL	0x0E	SWNL is ON when position command is less than software reverse limit(PF87), Otherwise, SWNL is off.
ABSW	0x0F	ABSW is to show Delta absolute encoder related alarm.
ABSV	0x10	If position of Mitsubishi absolute system is lost, ABSV is ON.
LOPM	0x17	LOPM shows current control mode(related to LOP) in switching control mode.

Note: PD27 can determine the DO output is normally open(a contact) or normally close (b contact).

9. Communication function

9.1 Communication hardware interface and wiring

The servo drive equips RS-485 and plug-play USB serial communication functions. You can use this function to drive the servo system, change the parameters and monitor the status of the servo system. However, RS-485 and USB communication functions cannot be used at the same time, the wiring instruction of RS485 is as follows:

RS-485

(1) External schematic diagram

You can use maximum 32 axis of servo drives from stations 1 to 32 on the same Bus

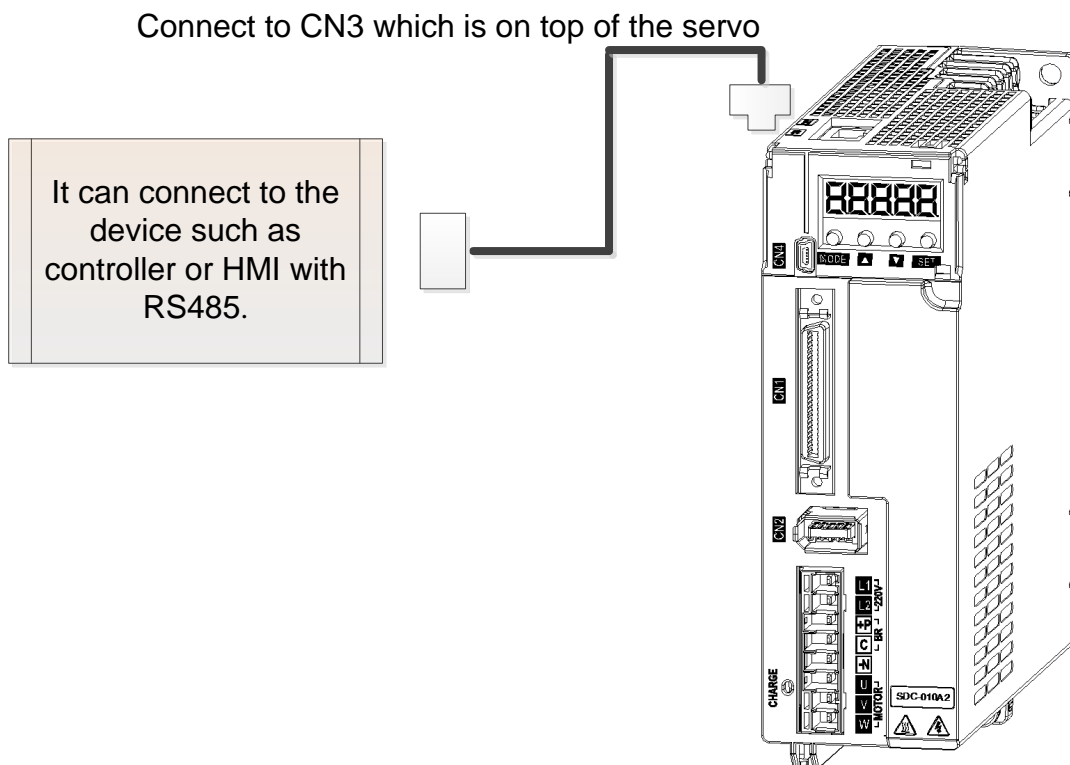

(2) Wiring diagram

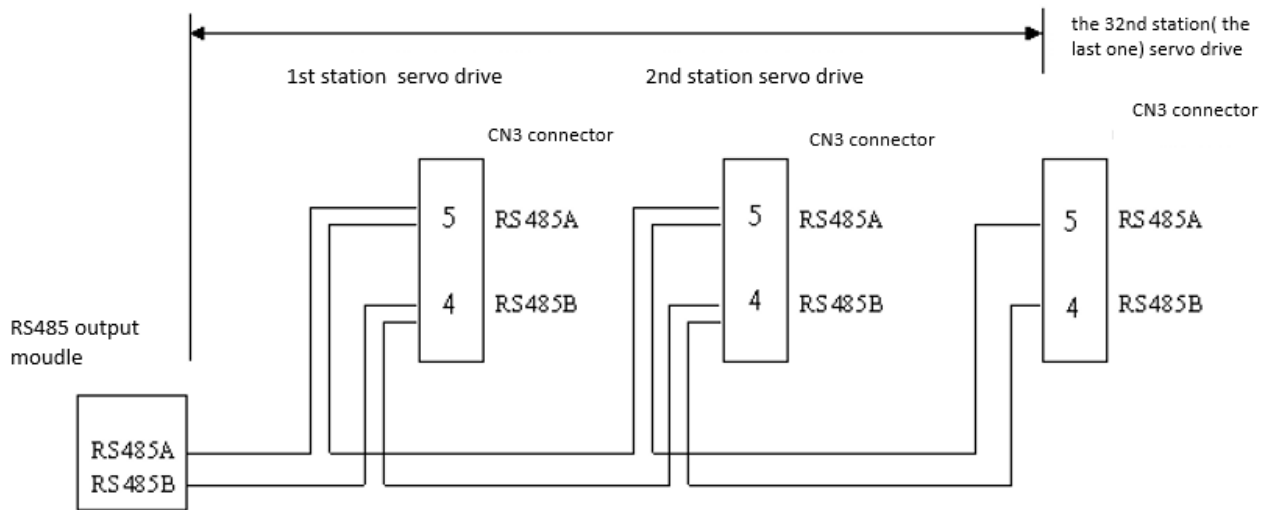

Note 1: the cable length can be up to 100 meters when the servo drive is installed in a quiet environment. If the transmission speed is over 38,400 bps, a 15-meter cable is recommended to ensure data transmission accuracy.

USB

(1) External schematic diagram

please use standard Mini-USB cable. It is recommended to use the USB cable with a magnetic ring, which has strong anti-interference function.

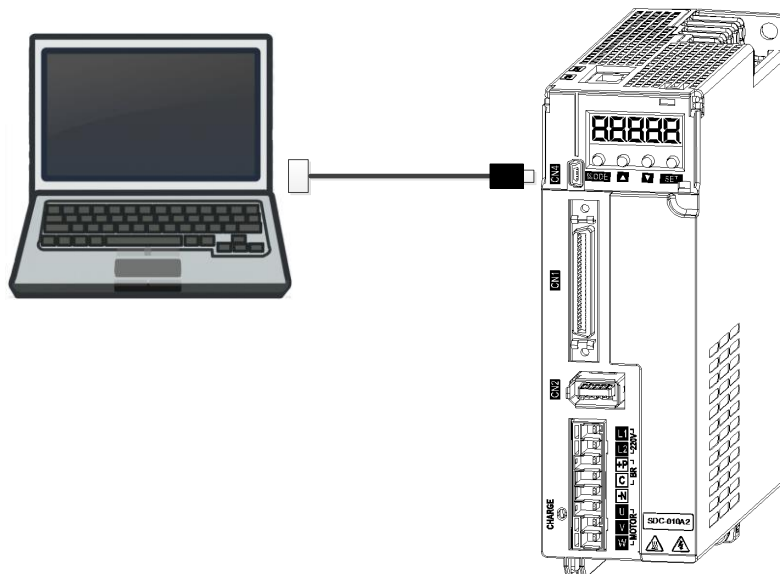

9.2 Communication specifications

When using RS-485 communication to operate servo drive, the communication specification of SERVO AMP is as follows:

(1) Communication device number (PC20)

Refer to PC20 and its setting range is 1~32.

(2) Communication protocol option (PC22)

0	0	y	x
---	---	---	---

x=0: 7 data bit, No parity, 2 Stop bit	(Modbus, ASCII Mode)
x=1: 7 data bit, Even parity, 1 Stop bit	(Modbus, ASCII Mode)
x=2: 7 data bit, Odd parity, 1 Stop bit	(Modbus, ASCII Mode)
x=3: 8 data bit, No parity, 2 Stop bit	(Modbus, ASCII Mode)
x=4: 8 data bit, Even parity, 1 Stop bit	(Modbus, ASCII Mode)
x=5: 8 data bit, Odd parity, 1 Stop bit	(Modbus, ASCII Mode)
x=6: 8 data bit, No parity, 2 Stop bit	(Modbus, RTU Mode)
x=7: 8 data bit, Even parity, 1 Stop bit	(Modbus, RTU Mode)
x=8: 8 data bit, Odd parity, 1 Stop bit	(Modbus, RTU Mode)

(3) communication baud rate (PC22)

0	0	y	x
---	---	---	---

y=0: 4800bps,	y=1: 9600bps,	y=2: 19200bps
y=3: 38400bps,	y=4: 57600bps,	y=5: 115200bps

9.3 Modbus communication protocol

Before communicating with the computer, each servo drive must set its station number(PC20), and then the computer will control the individual servo drive according to the station number. The communication method is MODBUS Networks , and there are two mode of MODBUS network communication: ASCII (American Standard Code for Information Interchange) and RTU (Remote Terminal Unit). You can set the communication mode(ASCII or RTU) by setting PC22 according to your requirements.

Note: USB and MODBUS cannot used at the same time.

The Shihlin servo drive provides these function codes: 0x03, 0x04, 0x06, 0x10, which can do relevant communication control with the host controller.

9.3.1. ASCII mode

(a) Code description

Every 8-bit data frame consists of two ASCII characters. For example, if 1 byte of data 75H (hexadecimal notation) is represented by ASCII "75", which contains the ASCII code of '7' (37H) and the ASCII code of '5' (35H).

(b)Frame signification

11 bit frame (for 8-bit data length)

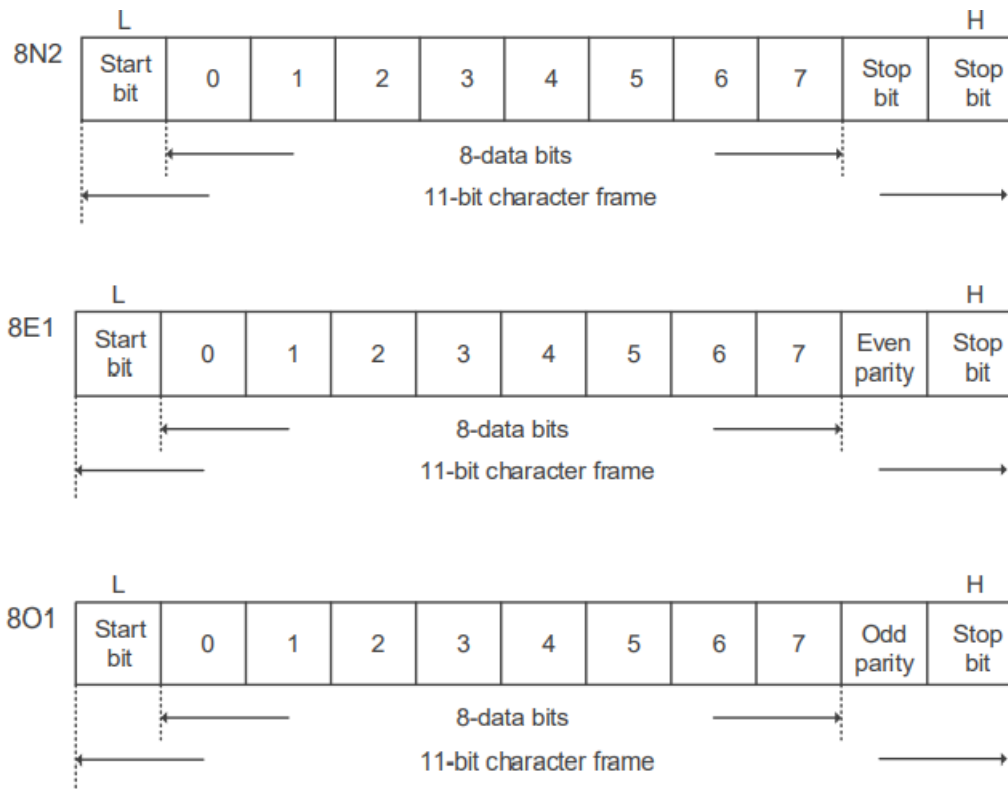

10 bit frame (for 7-bit data length)

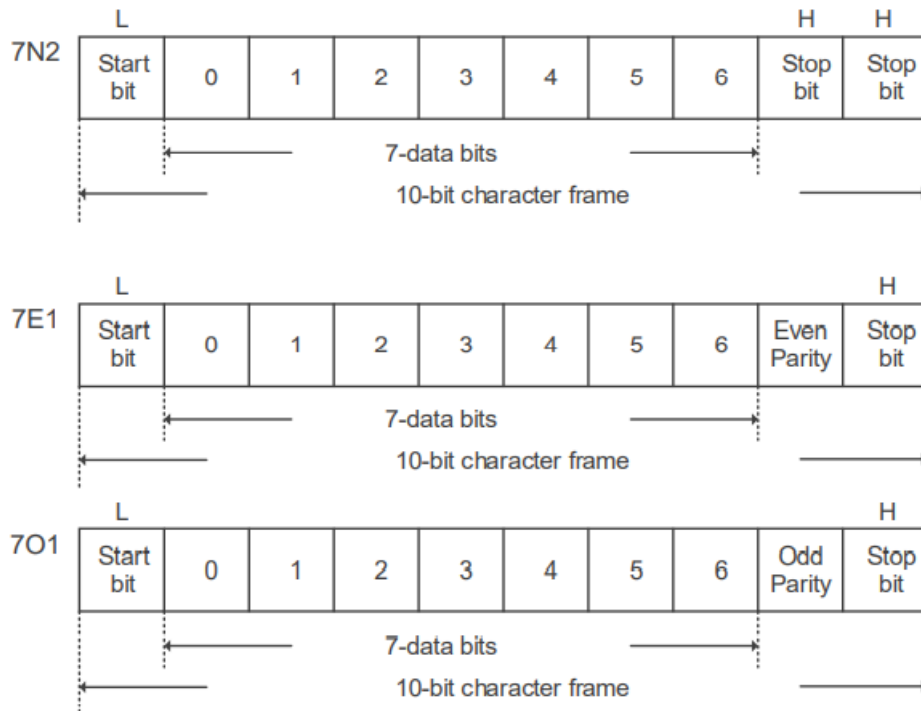

(c), Communication data structure

Bit code	Name	Description
STX	Start character	“.” (3AH) of ASCII.
ADR	Device number	1 byte consists of 2 ASCII codes
CMD	Function code	1 byte consists of 2 ASCII codes
DATA(n-1)	Data content	n-word = 2n-byte consists of 4n ASCII codes, $n \leq 29$
.....		
DATA(0)		
LRC	Error check	1 byte consists of 2 ASCII codes
End1	End code 1	(0DH) (CR) of ASCII.
End0	End code 0	0AH (LF) of ASCII

The detailed descriptions in the communication data format box are as follows:

STX(Communication start)

'.' character

ADR(Device number)

communication device number is 1~32. For example: communicate with the servo drive of device number 18 (hexadecimal 12H).

ADR='1','2' => '1'=31H,'2'=32H

CMD(Function code) and DATA(data word)

The format of data characters depends on the command code, The common used command codes are as follows:

Example 1, function code 03H, accessing N words:

The maximum N is 29, for example: reads 2 continuous words which the start address is 0100H from servo drive device number 01H.

Command message(Host)

STX	:
ADR	0
	1
CMD	0
	3
Start data address	0
	1
	0
	0

Response message(Slave)

STX	:
ADR	0
	1
CMD	0
	3
Byte length	0
	4

Word length	0		Content of start data address 0100H	0	
	0			1	
	0			0	
	2			2	
LRC check	F		Content of the 2nd data address 0101H	1	
	9			2	
End1	0DH(CR)			LRC check	C
					2
End0	0AH(LF)	End1	0DH(CR)		
		End0	0AH(LF)		

Example 2: function code 06H, writing single word

for example: writes data 325 (0145H) to start data address 0100H and the servo drive device number is 01H.

Command message(Host)

STX	:
ADR	0
	1
CMD	0
	6
Start data address	0
	1

Response message(Slave)

STX	:
ADR	0
	1
CMD	0
	6
Start data address	0
	1

	0
	0
Data content	0
	1
	4
	5
LRC check	B
	2
End1	0DH(CR)
End0	0AH(LF)

	0
	0
Data content	0
	1
	4
	5
LRC check	B
	2
End1	0DH(CR)
End0	0AH(LF)

Example 3 : Function code 10H, writing multiple words

Example: writes data 0BB8H and 0000H to the start data address 0112H and the servo drive device number is 01H. In other words, 0BB8H is written into 0112H and 0000H is written into 0113H. The maximum allowable data in one single access is 10.

Command message(Host)

STX	:
ADR	0
	1
CMD	1
	0
Start Data Address	0
	1
	1
	2

Response data(Slave)

STX	:
ADR	0
	1
CMD	1
	0
Start Data Address	0
	1
	1
	2

Data quantity (word)	0
	0
	0
	2
Data quantity (byte)	0
	4
Content of the 1 st Data	0
	B
	B
	8
Content of the 2nd Data	0
	0
	0
	0
LRC check	1
	3
End1	0DH(CR)
End0	0AH(LF)

Data quantity (word)	0
	0
	0
	2
LRC check	D
	A
End1	0DH(CR)
End0	0AH(LF)

LRC error check(ASCII mode)

The error check in ASCII mode is LRC (Longitudinal Redundancy Check). To calculate the LRC value: add all the data from ADR to the last one, take the result by using 256 as the unit, and the excess part is removed (for example, the result obtained after adding is 128H in hexadecimal, then only 28H is taken), and then calculate 2's complement. The 2's complement is LRC error value.

For example: read two words from the address 0104H and the servo drive device number is 01h.

$01H+03H+01H+04H+00H+02H = 0BH$. The two's complement of F5H, thus LRC is 'F','5'.

STX	:
ADR	0
	1
CMD	0
	3
Start Data Address	0
	1
	0
	4
Data quantity (word)	0
	0
	0
	2
LRC error check	F
	5
End1	0DH(CR)
End0	0AH(LF)

End1, End0(communication is completed)

Use “0Dh” which character is ‘\r’ [carriage return] and “0Ah” which character is ‘\n’ [new line] to denote the end of communication data packet.

9.3.2. RTU mode

(a) Code description.

Each 8-bit data consists of two 4-bit hexadecimal characters. For example: 1-byte data is expressed as 62H.

(b) Communication data structure

Data structure is as below:

Bit code	Name	Content
STX	Start word	To keep an idle more than 6mS
ADR	Device number	1 byte
CMD	Function code	1 byte
DATA(n-1)	Data content	n-word = 2n-byte, n<=29
.....		
DATA(0)		
CRC	Error check	2 byte
End	End code	To keep an idle more than 6mS

STX(start communication)

To keep an idle for more than 6mS.

ADR(Communication device number)

The device number is from 1 to 32. For example,the device number of the servo drive is 18 (hexadecimal 12H) ADR=12H.

CMD(Function code)and DATA(Data word)

The format of data characters are varied according to different function codes.

Example 1: function code: 03h, accessing multiple words.

The maximum allowable data in one single access is 29, for example: reads two continuous words from the start data address 0200H and the servo drive device number is 01H.

Command message(Host)

ADR	01H
CMD	03H
Start data address	02H(high byte)
	00H(low byte)
Data quantity(word)	00H
	02H
CRC Check Low	C5H(low byte)
CRC Check high	B3H(high byte)

Response message(Slave)

ADR	01H
CMD	03H
Data quantity(byte)	04H
Content of start data address 0100H	00H(high byte)
	B1H(low byte)
content of 2 nd data address 0100H	1FH(high byte)
	40H(low byte)
CRC Check Low	A3H(low byte)
CRC Check high	D4H(high byte)

Example 2: function code: 06H, writing single word.

For example: writes data 100(0064H)to start data address 0200H and the servo drive device number is 01H.

Command message(Host)

ADR	01H
CMD	06H
Start data address	02H(high byte)
	00H(low byte)
Data content	00H(high byte)
	64H(low byte)
CRC Check Low	89H(low byte)
CRC Check high	99H(high byte)

Response message(Slave)

ADR	01H
CMD	06H
Start data address	02H(high byte)
	00H(low byte)
Data content	00H(high byte)
	64H(low byte)
CRC Check Low	89H(low byte)
CRC Check high	99H(high byte)

Example 3 : function code 10H, writing multiple words.

writes data 0BB8H and 0000H to the start data address 0112H and the servo drive device number is 01H. In other words, 0BB8H is written into 0112H and 0000H is written into 0113H. The maximum allowable data in one single access is 10.

Command message(Host)

ADR	01H
CMD	10H
Start data address	01H(high byte)
	12H(low byte)
Data quantity (word)	00H(high byte)
	02H(low byte)
Data quantity(byte)	04H
Content of the 1st Data	0BH(high byte)
	B8H(low byte)
Content of the 2nd Data	00H(high byte)
	00H(low byte)
CRC Check Low	FCH(low byte)
CRC Check high	EBH(high byte)

Response message(Slave)

ADR	01H
CMD	10H
Start data address	01H(high byte)
	12H(low byte)
Data quantity (word)	00H(high byte)
	02H(low byte)
CRC Check Low	E0H(low byte)
CRC Check high	31H(high byte)

CRC error check(RTU mode) value calculation

The error check in RTU mode is CRC (Cyclical Redundancy Check) below is steps description to calculate CRC error check value:

Step 1: Load a 16-bit register with the content of FFFFH, which is called the "CRC" register.

Step 2: Perform Exclusive OR calculation between the first byte of the command message and the low byte of the 16-bit CRC register, and then save the result in the CRC register.

Step 3: Check the least significant bit (LSB) of the CRC register. If the bit is 0, shift the register one bit to the right. If the bit is 1, shift the register one bit to the right and execute (CRC register) XOR (A001H).

Step 4: Repeat step 3 for 8 times and then go to step 5.

Step 5: Repeat steps 2 and 3 until all bytes have been processed. The content of the CRC register is the CRC value.

Note:after calculating the CRC error check value, fill in the low word of the CRC value in the command message, and then the high word. Please refer to below example:

Example: reads two words from the data address 0101H and the servo drive device number is 01H. if the final content of the CRC register calculated from the ADR to the last byte of the data number is 3794H, the command message will be as follows. And you need note that 94H is transfer before 37H.

ADR	01H
CMD	03H
Start data address	01H(high byte)
	01H(low byte)
Data quantity	00H(high byte)
	02H(low byte)
CRC Check Low	94H(low byte)
CRC Check high	37H(high byte)

End1, End0(communication is completed)

Keeping an idle more than 6mS means communication is completed.

CRC program example

This function calculates the CRC value in the C language. It needs two parameters

unsigned char* data;

unsigned char length

This function will return the CRC value of unsigned integer type.

unsigned int crc_chk(unsigned char* data, unsigned char length)

```

{
    int j;
    unsigned int reg_crc=0xFFFF;
    while(length--)
    {
        reg_crc^= *data++;
        for (j=0; j<8; j++)
        {
            if(reg_crc & 0x01)          /*LSB(bit 0) = 1 */
                reg_crc = (reg_crc >> 1)^0xA001;
            else
                reg_crc = (reg_crc>>1);
        }
    }
    return reg_crc;
}

```

(c) Function code and error code.

The function code and error code of the servo drive is introduced as follows:

Function code	Description
03H	Read parameter
04H	Read parameter(Read only)
06H	Write one single parameter
10H	Write multiple parameter

Function code 03H indicates reading parameter, The maximum allowable parameter in one single access is 29.

Function code 04H indicates accessing the read only parameter, The maximum allowable parameter in one single access is 29.

Function code 06H indicates writing a single parameter.

Function code 10H indicates writing multiple parameters, and the maximum allowance is 10,

Error code	Description
01	Function code error
02	Parameter address error
03	Parameter range error

Error code 01H indicates the received function code is wrong.

Error code 02H indicates the received parameter address is wrong. The parameter address range should be within 0x0000~0x20FF.

Error code 03H indicates the received parameter value is out of range base on below items:

1. Check whether the number of read data exceeds the range and current data (word) ranges is from 1 to 29 words.
2. Check whether the written parameter value exceeds the parameter defined range. In current communication address (0x0000~0x20FF), most addresses have a defined range. If some addresses are reserved and not used, the range is -32728~32767.

When an error occurs in the received data, the function code will be added 0x80, which means an error has occurred. The following message will be returned.

(a) ASCII MODE

STX	':'
Slave Address	'0'
	'1'

(b) RTU mode

Slave Address	01H
Function	83H
Error code	02H

Function	'8'	CRC CHK Low	C0H
	'3'		F1H
Error code	'0'	CRC CHK High	
	'2'		
LRC CHK	'7'		
	'A'		
END1	CR		
END0	LF		

9.4 Setting and accessing communication parameters

(1) Status monitor(Read only)

Communication address	Content	Data length
0x0000	Motor feedback pulses [pulse]	2words
0x0002	Number of command pulses[pulse]	2words
0x0004	Number of pulses error [pulse]	2words
0x0006	Command pulse input frequency [Hz]	2words
0x0008	Motor speed [rpm]	2words
0x000A	Analog speed command/limit voltage [V] (Display 2 decimal point)	2words
0x000C	Speed input command/limit [rpm]	2words
0x000E	Analog Torque command/limit voltage [V] (Display 2 decimal point)	2words
0x0010	Torque input command/limit [%]	2words
0x0012	Effective load ratio [%]	2words

0x0014	Peak load ratio [%]	2words
0x0016	DC bus voltage [V]	2words
0x0018	Load to motor inertia ratio [times] (Display 1 decimal point)	2words
0x001A	Instantaneous torque [%]	2words
0x001C	Regeneration load ratio [%]	2words
0x0020	The absolute pulse number relative to encoder Z phase [pulse] (Note 1)	2words
0x0022	Pulse number of pulse position command(after E-gear) [pulse]	2words
0x0024	Motor feedback pulse number(before E-gear) [pulse]	2words
0x0026	Pulses error number(before E-gear) [pulse]	2words

Note 1: The absolute pulse number of encoder Z phase origin is 0. It is +5000 or -4999 pulses when the motor rotates in the forward or reverse direction as below picture shows:

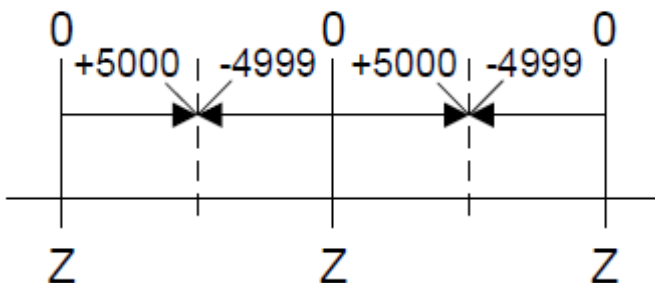

Every two Z-phase pulse commands interval is 10000 pulse.

(2) Digital IO monitor(read only)

(a) IO pin status

Communication address	Content	Data length
0x0204	To show the ON/OFF status of DI, the pin assignment is as follows	1word

Bit7	Bit6	Bit5	Bit4	Bit3	Bit2	Bit1	Bit0	Bit number
DI8	DI7	DI6	DI5	DI4	DI3	DI2	DI1	Pin number
Bit15	Bit14	Bit13	Bit12	Bit11	Bit10	Bit9	Bit8	Bit number
							DI9	Pin number

Note: The status of this digital IO pin is the integrated data with both input contact (DI) source control switch (PD16) and the communication control digital input contact status (PD25), below example will further illustrate this:

The external hardware terminals DI9~DI1 status are represented by bit8~bit0 in binary values as below:

Digital input contact source control switch (PD16): 111000000.

The state of the external hardware terminal: 100001111 (from left to right are DI9~DI1, 1 means ON, 0 means OFF).

Communication control digital input status (PD25): 000111000.

In summary, DI9~DI7 of the digital input terminal status (communication address 0x0204) is determined by the communication, and DI6~DI1 is determined by the status of the external hardware terminal.

Therefore, the status of digital input terminal (communication address 0x0204) is represented as 000001111.

Communication address	Content	Data length
0x0205	To show the ON/OFF status of DO, the pin assignment is as follows	1 word

Bit7	Bit6	Bit5	Bit4	Bit3	Bit2	Bit1	Bit0	Bit number
			DO 5	DO 4	DO 3	DO 2	DO 1	Pin number

(b) IO pin function

communication address	Content	Data length
0x0206~0x020D	Display the current DI/DO function definition, the pin assignment is as follows	1word

Note: if DI/DO functions are not applicable to the current control mode, return 0.

Ex: if in speed control mode, PD07=0x000B, then the bit0~bit7 of Address 0x0208 will return 0.

Address : 0x0206

Bit8~Bit15	Bit0~bit7	Bit number
DI1	DI2	Pin number
0x00~0x2F	0x00~0x2F	Function option

Address : 0x0207

Bit8~Bit15	Bit0~bit7	Bit number
DI3	DI4	Pin number
0x00~0x2F	0x00~0x2F	Function option

Address : 0x0208

Bit8~Bit15	Bit0~bit7	Bit number
DI5	DI6	Pin number
0x00~0x2F	0x00~0x2F	Function option

Address : 0x0209

Bit8~Bit15	Bit0~bit7	Bit number
DI7	DI8	Pin number
0x00~0x2F	0x00~0x2F	Function option

Address : 0x020A

Bit8~Bit15	Bit0~bit7	Bit number
DI9	N/A	Pin number
0x00~0x2F		Function option

Address : 0x020C

Bit8~bit15	Bit0~bit7	Bit number
DO2	DO1	Pin number
0x00~0x3F	0x00~0x3F	Function option

Address : 0x020D

Bit8~bit15	Bit0~bit7	Bit number
DO4	DO3	Pin number
0x00~0x3F	0x00~0x3F	Function option

Address : 0x020E

Bit8~bit15	Bit0~bit7	Bit number
N/A	DO5	Pin number
	0x00~0x3F	Function option

(c) Current control mode and servo status(Read only)

Communication address	Content	Data length
0x0200	Bit0 : Servo ready status (0:Servo OFF, 1:Servo ON)	1word
0x0201	Bit0~Bit3 : display current control mode of drive. 0: Pt mode(extern pulse-train command). 1:absolute Pr position mode.	1word

	2:incremental Pr position mode. 3:speed control mode 4:torque control mode	
--	--	--

Note 1: The DI function selection definition table is as follows:

0x07	0x06	0x05	0x04	0x03	0x02	0x01	0x00	Function selection code
SP2	SP1	TL1	TL	PC	RES	SON	N/A	Signal code
0x0F	0x0E	0x0D	0x0C	0x0B	0x0A	0x09	0x08	Function selection code
CR	CM2	CM1	SHOM	ORGP	ST2/RS1	ST1/RS2	SP3	Signal code
0x17	0x16	0x15	0x14	0x13	0x12	0x11	0x10	Function selection code
	CTRG	POS3	POS2	POS1	EMG	LOP	CDP	Signal code
0x1F	0x1E	0x1D	0x1C	0x1B	0x1A	0x19	0x18	Function selection code
EV2	EV1	INHP	POS6	POS5	POS4	LSN	LSP	Signal code
			0x24	0x23	0x22	0x21	0x20	Function selection code
			STOP	ABSC	ABSE	EV4	EV3	Signal code
0x2F	0x2E	0x2D	0x2C	0x2B	0x2A	0x29	0x28	Function selection code
Pt-Pr	TC2	TC1						Signal code

Note 2: The DO function selection definition table is as follows:

0x05	0x04	0x03	0x02	0x01	0x00	Function selection code
TLC/VLC	HOME	INP/SA	ALM	RD	N/A	Signal code
0x0B	0x0A	0x09	0x08	0x07	0x06	Function selection code

MC_OK	OLW	CMDOK	ZSP	WNG	MBR	Signal code
		0x0F	0x0E	0x0D	0x0C	Function selection code
		ABSW	SWNL	SWPL	OVF	Signal code
				0x20~0x2F		Function selection code
				SDO_0 ~ SDO_F		Signal code

(3)Alarm information(Read only)

Communication address	Content	Data length
0x0100	Current alarm	1word
0x0101	The last alarm	1word
0x0102	The 2nd alarm in the past	1word
0x0103	The 3rd alarm in the past	1word
0x0104	The 4th alarm in the past	1word
0x0105	The 5th alarm in the past	1word
0x0106	The 6th alarm in the past	1word
0x0107	The 7th alarm in the past	1word
0x0108	The 8th alarm in the past	1word
0x0109	The 9th alarm in the past	1word
0x010A	The 10th alarm in the past	1word

Note: return 0x00ff means no alarm, return 0x0001 means AL.01, return 0x0012 means AL.12, and so on.

(4) Alarm data clearance (readable and writable)

Communication address	Content	Data length
0x0130	Clear current alarm if “0x1EA5” is written into this address. return current alarm code when accessing this address. The setting range is 0~0xFFFF.	1word
0x0131	Clear all the alarm record if “0x1EA5” is written into this address. return the last alarm when accessing this address.. The setting range is 0~0xFFFF.	1word

(5) Parameter reading and writing (readable and writable)

Communication address	Content	Data length
0x0300~0x03C5	There are 50 parameters in PA group, and the data length of each parameter is 32 bits and occupying 2 addresses: such as PA01: 0x0300~0x0301.	2word
0x0400~0x04C5	There are 60 parameters in PB group, and the data length of each parameter is 32 bits and occupying 2 address, such as PB01: 0x0400~0x0401.	2word
0x0500~0x05C5	There are 99 parameters in PC group, and the data length of each parameter is 32 bits and occupying 2 address, such as PC01 : 0x0500~0x0501.	2word
0x0600~0x06C5	There are 40 parameters in PD group, and the data length of each parameter is 32 bits and occupying 2 address, such as PD01 : 0x0600~0x0601.	2word
0x0700~0x07C5	There are 99 parameters in PE group, and the data length of each parameter is 32 bits and occupying 2 address, such as PE01 : 0x0700~0x0701.	2word
0x0800~0x08C5	There are 99 parameters in PF group, and the data length of each parameter is 32 bits.	2word

Note 1: the maximum allowance data in one access is 29 (29 words).

Note 2: When writing PA~PH group parameters by communication with MODBUS 0x06 or 0x10 function code, the drive firmware should check that if the written value exceed the range. If it exceed the range and communication error will occur, you can refer to P16 for instruction.

(6) Reset to the factory default value(readable and writable)

Communication address	Content	Data length
0x0140	<p>After writing data 0x1EA5, all parameters of PA~PF group will be reset to the default value, and the writing will be completed after 3 seconds.</p> <p>The setting range is 0~0xFFFF</p> <p>When reading this parameter, if 1 is returned, which means the drive is still writing EEPROM, and if 0 is returned, which means the writing to EEPROM is completed.</p>	1word

(7)Software input contact control(readable and writable)

Step 1: select the input mode of DI contact.

Communication address	Content	Data length
0x061E	<p>Digital input control source option(PD16)</p> <p>In this parameter, each bit determines the signal input control source of 1 DI.</p> <p>Bit0 ~ Bit8 correspond to DI1 ~ DI9</p> <p>Bit setting shows as below:</p> <p>0: input contact status is controlled by external hardware terminal.</p> <p>1: input contact status is controlled by communication(PD25).</p>	2word

--	--	--

Step 2:writing DI contact on/off status

Communication address	Content	Setting range	Data length
0x0630	<p>To write the status of digital input terminal(ON/OFF) as shown in below:</p> <p>Writing data is valid only when the bit of PD16 corresponding SDI is 1, otherwise the actual digital input contact status will be still controlled by external hardware contact.</p> <p>Refer to PD25 for details.</p>	<p>0000h</p> <p>~</p> <p>01FFh</p>	2word

Bit7	Bit6	Bit5	Bit4	Bit3	Bit2	Bit1	Bit0	Bit number
SDI8	SDI7	SDI6	SDI5	SDI4	SDI3	SDI2	SDI1	Pin name

Bit9~Bit31	Bit8
All those bit values should be set as 0.	SDI9

Note: Cautions for test mode (terminal forced output control, JOG test, positioning test)

When using the communication commands in the test mode, the user must pay attention to the following matters, otherwise the drive will not work normally in the test mode

1. The drive can enter the test mode only when there is no alarm and the servo is in servo off state.
2. In the test mode, if the communication is interrupted for more than 1 second, the drive will turn Servo Off and exit the test mode. Therefore, the Host device should perform uninterrupted DI communication in the test mode (each communication command needs to be sent within 1 second). There are no special restrictions on the address for communication command checking. For example , to maintain the continuous communication status, you can send read command repeatedly to the communication address 0x0900.
3. After entering the test mode (terminal forced output control, JOG test, positioning test), The normal external hardware signal and software contact signal is invaled,except the EMG signal.

(8)DO force output control(readable and writable)

Step 1: Access the alarm and Servo ON information from the following communication address to make sure that there is no alarm and the servo is in servo Off status at present, otherwise the test mode will not be performed.

Communication address	Content	Data length
0x0900 (Read only)	0x0UVW, in which UV=Alarm information, W=1 means SON signal ON, W=0 means SON signal OFF	1word

Step 2: Enter Forced DO mode and write data 0x0002, the definition of its communication address is as follows:

Communication address	Content	Setting range	Data length
0x0901	To switch operation mode 0000: Exit test mode 0001: Reserved 0002: DO forced output(Output signal forced output) 0003: JOG operation 0004: positioning operation	0000~0004	1word

Note: When writing data 0x0002~0x0004 to the address 0x0901, the test mode cannot be entered during SERVO ON.

Step 3: writing DI contact on/off status

Communication address	Content	Setting range	Data length
0x0203	To write DI contact on/off status,as shown below	0~0x003F	1word

Bit5~Bit15	Bit4	Bit3	Bit2	Bit1	Bit0	Bit number
	DO5	DO4	DO3	DO2	DO1	Pin number

Step 4: Exit Forced DO mode: write data 0x0000 to the communication address 0x0901

(9)JOG test(readable and writable)

Step 1: Access the alarm and Servo ON information from the following communication address to make sure that there is no alarm and the servo is in servo Off status at present, otherwise the test mode will not be performed.

Communication address	Content	Data length
0x0900 (Read only)	0x0UVW, in which UV=Alarm information, W=1 means SON signal ON, W=0 means SON signal OFF.	1word

Step2: Enter JOG mode: write data 0x0003 to the communication address 0x0901.

Step 3: Set the acceleration and deceleration time constant of JOG mode.

Communication address	Content	Data length
0x0902	To set acceleration and deceleration time constant of JOG mode and positioning mode. (Range: 0~20000)(unit: ms)	1word

Step4: Set JOG speed command and start.

Communication address	Content	Data length
0x0903	To input the speed command of JOG and positioning mode (Range0~6000) (unit: rpm)	1word

Step 5: JOG operation

Communication address	Content	Data length
0x0904	0: JOG operation is stopped. 1: JOG operation is running forwardly. 2: JOG operation is running reversely. The setting range is 0~2.	1word

Step 6: exit JOG mode, write data 0x0000 to communication address 0x0901.

(10) Positioning test (readable and writable)

Step 1: Access the alarm and Servo ON information from the following communication address to make sure that there is no alarm and the servo is in servo Off status at present, otherwise the test mode will not be performed.

Communication address	Content	Data length
0x0900 (Read only)	0x0UVW, in which UV=Alarm information, W=1 means SON signal ON, W=0 means SON signal OFF.	1word

Step 2: Enter positioning mode: write data 0x0004 to the communication address 0x0901.

Step3: Set the acceleration and deceleration time constant.

Communication address	Content	Data length
0x0902	To set acceleration and deceleration time constant of JOG mode and positioning mode.	1word

	(Range: 0~20000)(unit: ms)	
--	----------------------------	--

Step 4: Set positioning speed command

Communication address	Content	Data length
0x0903	To input the speed command of JOG and positioning mode (Range:0~3000)(Unit:rpm)	1word

Step 5: Set the command pulse number of positioning mode

Communication address	Content	Data length
0x0905~ 0x0906	Pulse number in positioning mode (0x0905 returns low 16 bits, 0x0906 returns high 16 bits). The range is 0~ (2 ³¹ -1) (unit :pulse)	1word

Step 6: positioning test operation

Communication address	Content	Data length
0x0907	When the written data is 0, it means that the positioning operation is paused/stopped (send the command during the operation will pause operation, and send the 2 nd command will stop the operation) When the written data is 1, it means the positioning operation is running forwardly When the written data is 2, it means that the positioning operation is running reversely (after the drive receives the data, the position command will change to a negative value inside) (The setting range is 0~2)	1word

Step 7: Exit positioning mode: write data 0x0000 to the communication address 0x0901.

10. Troubleshooting



CAUTION

- When an alarm occurs, eliminate its cause first to ensure safety. Wait until the alarm is cleared and then restart operation, otherwise, it may cause injury.
- When alarm such as AL03, AL05, AL10, AL.34 occurs, please check the cause and eliminate it, turn off the power for more than 30 seconds to cool down the temperature of power module, and then restart the drive power to avoid the repeated occurrence of alarms causing damage to the drive.

10.1 Alarm list and corrective actions

An alarm or warning will be displayed when an error occurs during operation. please follow the section 11.2 to take appropriate actions. Setting PD19 to xxx1 to output the alarm code.

The alarm code is output based on the ON/OFF status between each PIN and SG, and the warning (AL12-AL1B) has no number.

When an alarm occurs, the output is alarm code in below list. In normal operation, the output is the setting signal before alarm occurs.

(CN1-41: DO1,CN1-42: DO2,CN1-45: DO5)

	Display	Alarm code			Alarm name	Alarm elimination		
		CN1 41	CN1 42	CN1 45		Power OFF→ON	"SET"Press SET button	RES signal
Alarm	AL.01	0	1	0	Over voltage	○		
	AL.02	0	0	1	Under voltage	○	○	○
	AL.03	0	1	1	Over current	○		
	AL.04	0	1	0	Regenerative error	○	○	○
	AL.05	1	0	0	Overload 1	○	○	○
	AL.06	1	0	1	Over speed	○	○	○
	AL.07	1	0	1	Abnormal pulse command	○	○	○
	AL.08	1	0	1	Excessive deviation of Position command	○	○	○
	AL.09	0	0	0	Serial communication error	○	○	○
	AL.0A	0	0	0	Serial communication timeout	○	○	○

	AL.0B	1	1	0	Encoder error 1	○		
	AL.0D	1	1	0	Fan error	○		
	AL.0E	0	0	0	IGBT overheat	○		
	AL.0F	0	0	0	Memory error	○		
	AL.10	0	0	0	Overload 2	○		
	AL.11	1	1	1	Motor combination error	○		
	AL.20	1	1	1	Motor collision error	○		
	AL.21	1	1	1	Motor power cable disconnection	○		
	AL.22	1	1	0	Encoder communication error	○		
	AL.24	0	0	0	Motor encoder type error	○		
	AL.26	1	1	0	Encoder error 3	○		
	AL.27	1	1	0	Encoder error 4	○		
	AL.28	1	1	0	Encoder overheat	○		
	AL.29	1	1	0	Encoder 5(overflow)	○		
	AL.2A	1	1	0	Absolute encoder error 1	○		
	AL.2B	1	1	0	Absolute encoder error 2	○		
	AL.2E	0	1	1	Control circuit error	○		
	AL.2F	0	1	1	Regenerative energy error	○		
	AL.30	0	1	1	Pulse output frequency excess	○	○	○
	AL.31	0	1	1	Over current 2	○		
	AL.32	0	1	1	Control circuit error 2	○		
AL.33	0	1	1	Memory error 2	○			
AL.34	0	0	0	Overload 4	○			
Warning	AL.12			Emergency stop	After eliminating the cause, it can be automatically released.			
	AL.13			Forward and reverse limit error				
	AL.14			Software positive limit				
	AL.15			Software negative limit				
	AL.16			Early overload warning				
	AL.17			ABS timeout warning				
	AL.18			Reserved				
	AL.19			Pr command error	Executing homing			
	AL.1A			Index coordinate undefined	After eliminating the cause, it can be automatically released.			
	AL.1B			Position shift warning				

AL.61		Parameter group of PR is out of range	○	○(Note1)	○
AL.1C		Early overload warning 4	After eliminating the cause, it can be automatically released.		
AL.2C		Absolute encoder error 3	After eliminating the cause, it can be automatically released.		
AL.2D		Encoder battery under voltage	Eliminate the cause, and then restart power.		
AL.62		Parameter number of PR is out of range	○	○	○
AL.63		Parameter value of PR is out of range	○	○	○
AL.64		Parameter setting of PR is in error	○	○	○

Note 1: turn Servo OFF → Servo ON can also eliminate the alarm.

Note 2: if an alarm occurs, DO ALM will activate.

Note 3: if a warning occurs, DO WNG will activate.

10.2 Causes and corrective actions

AL.01 Over voltage

Alarm cause	Checking method	Corrective action
Main circuit voltage exceeds the rated value.	Use a voltmeter to check whether the main circuit input voltage is within the rated allowable voltage value.	Use the correct voltage source or connect to the transformer in series.
Incorrect power input (incorrect power system).	Use a voltmeter to check if the voltage system complies with the specifications.	Use the correct voltage source or connect to the transformer in series.
Malfunction of the servo drive hardware.	Use a voltmeter to check whether the input voltage of the main circuit is within the rated allowable voltage value, if yes, and the error still occurs.	Send your servo drive back to the distributor or manufacturer.
Internal regenerative resistor or regenerative option is disconnected.	Check whether the PD short-circuited piece is connected correctly, or whether the regenerative resistor or option wiring is disconnected.	Wire the short-circuited piece correctly or change the wiring cable.
Burned or damaged of the internal regenerative resistor or regenerative option.	Check whether the regenerative resistor or regenerative option is burnt or damaged.	When using the internal regenerative resistor, please replace the driver; When using the regenerative option, please replace it.
The capacity of internal regenerative resistor or regenerative option is insufficient.	Refer to section 6.6.1 " Check the capacity of regenerative resistor".	Increase the capacity or add additional regeneration option.

AL.02 Under voltage

Alarm cause	Checking method	Corrective action
The input voltage of the main circuit is lower than the allowable rated value.	Check if the wiring of input voltage for the main circuit is normal.	Recheck the voltage wiring.
No voltage input to the main circuit.	Use a voltmeter to check if the voltage for the main circuit is normal	Recheck the voltage switch.

Incorrect power input (incorrect power system).	Use a voltmeter to check if the power system complies with the specifications.	Use the correct voltage source or connect to the transformer in series.
---	--	---

AL.03 Over-current

Alarm cause	Checking method	Corrective action
Motor wiring is in error.	Check the wire connection sequence between the motor and the servo drive.	Followed the wiring sequence as described in this manual.
The servo drive output is short-circuited.	Check the connection between the motor and servo drive and make sure that the wire is not short-circuited.	Check and make sure that the wire is not short-circuited. Do not expose the metal part of the wiring.
IGBT is abnormal.	Check if the temperature of the heat sink is abnormal.	Send your servo drive back to the distributor or manufacturer.
Parameter setting is in error.	Check if the set value of the parameter is much greater than the default.	Reset the parameter to the factory default setting and then modify the setting gradually.

AL.04 Regeneration error

Alarm cause	Checking method	Corrective action
Invalid regenerative switching transistor.	Check if the regeneration switching transistor is short-circuited.	Send your servo drive back to the distributor or manufacturer.
The regenerative resistor is not connected.	Check the connection for the regenerative resistor.	Reconnect the regenerative resistor.

AL.05 Overload 1

Alarm cause	Checking method	Corrective action
The load is over the rated range and the servo drive is in a continuous overload condition.	Check if the load is too heavy.	Increase the motor capacity or reduce the load.
Improper parameter setting.	Check if there is any mechanical vibration.	Execute auto gain tuning for proper gain value.
Unstable system.	Setting for acceleration or deceleration is too drastic..	Slow down the setting for acceleration or deceleration time.
Incorrect wiring of motor and encoder.	Check if the wiring of the UVW and the encoder cables are correct.	Wiring correctly.

AL.06 Over speed

Alarm cause	Checking method	Corrective action
The input frequency of the pulse command is too high.	Check whether the input frequency of the pulse command is too high.	Correctly set the pulse frequency.
Improper setting for acceleration and deceleration time parameter.	Check whether the acceleration and deceleration time constant is too small.	Increase the acceleration and deceleration time constant.
Unstable servo system which cause large overshoot.	Check whether the system has been vibrating.	1. Adjust gain to proper value. 2. if not useful, you can (a)decrease the load inertia ratio. (b)change the accelerate and decelerate time constant.

AL.07 Abnormal pulse command

Alarm cause	Checking method	Corrective action
The frequency of the pulse command is over the rated value	Use the scope to check the input frequency.	Correctly set the input pulse frequency.
Input pulse command device failure.	Replace the input pulse command device.	

AL.08 Excessive deviation of Position command

Alarm cause	Checking method	Corrective action
Improper setting of acceleration and deceleration time parameter.	Check if the acceleration and deceleration time constant is too small.	Increase the acceleration and deceleration time constant.
Improper torque limit setting.	Check if the torque limit parameter(PA05) setting is too small.	Increase the torque limit parameter setting value.
Gain value is set too low.	Check if the position gain value(PB07) is too small.	Increase the position loop gain value.
Excessive external load.	Check the external load.	Reduce the external load or re-evaluate the motor capacity.

AL.09 Serial communication error

Alarm content: AL09 occurs when RS485 communication failure.

Alarm cause	Checking method	Corrective action
Incorrect communication protocol setting.	Check if the communication protocol setting is correct.	Correctly set the communication parameter value.
Incorrect communication address.	Check communication address.	Correctly set communication address.
Incorrect communication value.	Check the access value.	Correctly set the value.

AL.0A Serial communication timeout

Alarm cause	Checking method	Corrective action
Servo drive has not received the communication message for a long time and has timed out	Check if the communication cable is loose or broken.	Replace the cable or reconnect the wiring.
Improper parameter setting for PC23.	Check the setting value of PC23.	Correctly set the value of PC23.

AL.0B Encoder error 1

Alarm cause	Checking method	Corrective action
Encoder wiring is incorrect.	Check if the wiring follows the instructions in the user manual.	Connect the wiring correctly.
Encoder connector is loose.	Check the connection.	Reconnect the connector.
Encoder is damaged.	Check if the motor is abnormal.	Replace the motor.
Encoder wiring is poor.	Check if there is any poor wiring.	Reconnect the wiring.

AL.0D Fan error

Alarm cause	Checking method	Corrective action
Drive fan stops working.	Turn off the power, replace the fan by yourself or send your servo drive back to the distributor or manufacturer.	

AL.0E IGBT overheat

Alarm cause	Checking method	Corrective action
The load is continuously over the rated range or the servo drive output is short-circuited.	Check if servo drive is overloaded or motor is over-current. Check if the wiring of servo drive output is correct.	Increasing the motor's capacity or reducing the load.

AL.0F Memory error

Alarm cause	Checking method	Corrective action
Memory data access abnormal.	Reset parameter or restart power.	If the issue persists, after the drive is reset, send it back to the distributor or manufacturer.

AL.10 Overload 2

Alarm cause	Checking method	Corrective action
Mechanical collision.	Check if there is a problem with the rotation cycle.	Adjust the operation curve or install limit switches.
Motor wiring is wrong.	Check the motor wiring.	Wiring correctly.
The System is operating with vibration.	Check if the mechanical has high frequency noise.	Reduce the stiffness setting or change to manual adjust gain.
Encoder error	Check if encoder is normal.	Change servo motor.

AL.11 Motor combination error

Alarm cause	Checking method	Corrective action
Motor and driver capacity is inconsistent.	Check if they match for each other in capacity.	Use the correct motor.

AL.12 Emergency stop

Alarm content: AL.12 occurs when press emergency stop button.

Alarm cause	Checking method	Corrective action
Press emergency stop button.	Check the button position.	Turn on the emergency stop button.

AL.13 Forward and reverse limit error

Alarm cause	Checking method	Corrective action
Positive limit switch is triggered.	Check the position of the switch.	Turn on the positive limit switch.
Negative limit switch is triggered.	Check the position of the switch.	Turn on the negative limit switch.

AL.14 Software positive limit

Alarm cause	Checking method	Corrective action
In Pr Mode, the position command pulse number exceeds the software positive limit PF86.	The software positive limit is calculate based on the position command rather than the actual feedback position, because the command always arrives earlier than the feedback. When this limit protection is activated and the actual position may not exceed the limit, you can set an appropriate deceleration time to achieve the desired effect. You can refer to the description on PF86.	Adjust the pulse number of the current position command to be less than the software positive limit.

AL.15 Software negative limit

Alarm cause	Checking method	Corrective action
In Pr Mode, the position command pulse number less than the software negative limit PF87.	1. Stop immediately or decelerate to stop according to PF81 setting and keep locked.	Adjust the pulse number of the current position command to be greater than the software negative limit.

AL.16 Early overload warning

Alarm cause	Checking method	Corrective action
The load exceeds the setting time of the protection curve xPA17. (Please refer to section 13. 3 of SDC manual for protection curve) .	1. Check whether the load is too heavy. 2. Check whether the PA17 setting is too low.	1. Refer to AL.05 corrective action. 2. Increase the setting value of PA17 or set the value to more than 100 to disable this function.

AL.17 ABS timeout warning

Alarm cause	Checking method	Corrective action
The signal waiting time of absolute position communication is too long.	Delta DIO communication: In absolute position communication, after the drive data is ready (ABSR), whether the host controller send a request (ABSQ) for more than 5 seconds. Mitsubishi DIO communication: Please refer to section 14. 1. 5 item 3. (Transmission Error).	Turn off the ABSE or ABSM signal to release the alarm, and check whether the communication format of the host controller is wrong.

AL.19 Pr command error

Alarm cause	Checking method	Corrective action
The position command counter overflow.	Incremental system: If in Pr mode, the motor keeps running in a single direction, it will cause the feedback position register overflow and the coordinate system fail to reflect the correct position. This error occurs if the PR absolute positioning command is issued at this time. Absolute system: This error occurs when the absolute positioning command is issued in the following conditions: 1. The feedback position register overflows. 2. The homing program has not been executed after changing the electronic gear ratio (PA06, PA07). 3. Execute absolute position command when DO HOME signal is OFF.	Execute homing.

AL.20 Motor collision error

Alarm cause	Checking method	Corrective action
When the motor current reaches the set value of PA15 and the protection time of PA16 has run out.	1. Check if PA15 is on 2. Check if PA15 setting is too low, and if PA16 setting time is too short.	1. Set PA15 to 0 if you open it by mistake. 2. Compared with the actual torque setting, if the setting is too low, it will malfunction, and if the setting is too high, the protection function will be invalid.

AL.21 Motor power cable disconnection

Alarm cause	Checking method	Corrective action
When Motor U,V,W cable disconnection is detected.	Check if the Motor U,V,W cable is loose.	Reconnect the U,V,W cables.

AL.22 Encoder communication error.

Alarm cause	Checking method	Corrective action
The encoder has three consecutive CRC code errors or internal memory errors.	<ol style="list-style-type: none"> 1. Check the grounding of motor. 2. Check whether the encoder signal line is separated from the power line or high current line to avoid interference. 3. Check whether the wire of encoder has an shielding net. 	<ol style="list-style-type: none"> 1. Connect the U,V,W ground terminal (green wire) to the heat sink base of the drive 2. Please separate the encoder cable from the motor power lines and high current line. 3. Use the wire with shielding net 4. If the issue persists, send it back to the distributor or manufacturer.

AL.24 Motor encoder type error

Alarm cause	Checking method	Corrective action
Incremental motors are not allowed to use absolute functions.	<ol style="list-style-type: none"> 1. Check whether the motor has an incremental or absolute encoder. 2. Check PA28. 	Use an absolute motor if you want to use the absolute function. Set PA28 to 0 if you do not use the absolute function,

AL.26 Encoder error 3

Alarm cause	Checking method	Corrective action
Encoder LED light decay or encoder rotation count value is abnormal.	Restart the motor and check whether the alarm recurs.	If the issue persists,send it back to the distributor or manufacturer.

AL.27 Encoder error 4

Alarm cause	Checking method	Corrective action
The internal memory of the encoder error.	<ol style="list-style-type: none"> 1. Check the grounding of motor. 2. Check whether the encoder signal line is separated from the power line or high current line to avoid interference. 3. Check whether the wire of encoder has a shielding net. 	<ol style="list-style-type: none"> 1. Connect the U,V,W ground terminal (green wire) to the heat sink base of the drive. 2. Please separate the encoder cable from the motor power lines and high current line. 3. Use the wire with shielding net. 4. If the issue persists, send it back to the distributor or manufacturer.

AL.28 Encoder overheat

Alarm cause	Checking method	Corrective action
Encoder operating temperature is higher than 95°C.	Put encoder away from heat source and do not operate in high temperature environment.	<ol style="list-style-type: none"> 1. Do not operate in high temperature environment and wait for the encoder board cool down to room temperature. 2. If the issue persists, send it back to the distributor or manufacturer.

AL.29 Encoder error 5

Alarm cause	Checking method	Corrective action
The revolution number of the absolute motor is out of range.	Check if the number of revolution of the motor during operation within the range between -32768 and +32767.	Re-execute homing and initialize absolute coordinate according to chapter 14 description.

AL.2A Absolute encoder error 1

Alarm cause	Checking method	Corrective action
Encoder backup battery voltage is too low.	Check whether the battery voltage is lower than 2.45V (TYP).	Replace the battery, and then re-execute homing and initialize absolute coordinate according to the description of chapter 14 or PA29.
Poor contact or disconnection of battery power supply circuit.	<ol style="list-style-type: none"> 1. Check the encoder wiring. 2. Check the connection between the battery external box and drive. 	<p>Connect or fix the connection to make sure the power supply of the encoder is normal, and then re-execute homing</p> <p>Refer to the description in Chapter 14.</p>

AL.2B Absolute encoder error 2

Alarm cause	Checking method	Corrective action
The revolution number of absolute encoder is in error.	Restart the motor and check whether the alarm recurs.	If the issue persists, send it back to the distributor or manufacturer.

AL.2C Absolute encoder error 3

Alarm cause	Checking method	Corrective action
Replace the battery when the drive control power is OFF.	Do not replace or remove the battery when the drive control power is OFF.	Re-execute homing and initialize absolute coordinate according to chapter 14 description or PA29.
After activating the absolute function, the absolute position coordinate initialization has not been completed.	<ol style="list-style-type: none"> 1. Install the battery 2. Check the connection between the battery external box and drive. 3. Check the encoder wiring 	Execute homing and initialize absolute coordinate according to chapter 14 description or PA29.

AL.2D Encoder battery under voltage

Alarm cause	Checking method	Corrective action
Encoder backup battery voltage is too low.	<ol style="list-style-type: none"> 1. Check whether the panel battery voltage is lower than 3.0V (TYP). 2. Check if the battery voltage is lower than 3.0(TYP). 	Replace the battery with a new one when the drive control power is ON and re-power on servo drive to eliminate the AL.2D.

AL.2E Control circuit error

Alarm cause	Checking method	Corrective action
When the motor is running with large external load, the servo ON (SON) state is instantly turned OFF→ON.	Check whether the servo ON (SON) is operate by mistake.	Correctly operate the servo ON (SON) command.
The drive current feedback is abnormal.	Restart the servo drive. If the issue persists, send your servo drive back to the distributor or manufacturer.	

AL.2F Regenerative energy error

Alarm cause	Checking method	Corrective action
When the regenerative load rate exceeds 100%.	<ol style="list-style-type: none"> 1. Check if the acceleration and deceleration time is too short. 2. Check whether the frequency of forward and reverse rotation is too fast. 	<ol style="list-style-type: none"> 1. Adjust the acceleration and deceleration time, or reduce the frequency of forward and reverse rotation. 2. Turn off and turn on the power to restart the servo drive.

AL.30 Pulse output frequency excess

Alarm cause	Checking method	Corrective action
Pulse output error which is caused by encoder error.	Check the error history to see whether it is accompanied with an encoder error (AL0B, AL0C, AL22, AL26, AL27).	Follow the corrective action of AL.0B, AL.0C, AL.22, AL.26, AL.27.
The output pulse exceeds the hardware allowable range.	Check whether the following conditions are occurred: (a) Motor feedback speed > PA41. (b) (Motor speed/60) x number of pulses output per revolution of the encoder > 20×10^6	Correctly set PA41 and PA14: PA41 > motor speed and (motor speed/60) x the number of pulses output per revolution of the detector < 20×10^6

AL.31 Over current 2

Alarm cause	Checking method	Corrective action
The drive current feedback is abnormal.	Restart the drive. If the issue persists, send your servo drive back to the distributor or manufacturer.	

AL.32 Control circuit error 2

Alarm cause	Checking method	Corrective action
The FPGA chip inside the drive is abnormal.	Restart the drive. If the issue persists, send your servo drive back to the distributor or manufacturer.	

AL.33 Memory error 2

Alarm cause	Checking method	Corrective action
Cache abnormal.	Restart the drive. If the issue persists, send your servo drive back to the distributor or manufacturer.	

AL.34 Over load 4

Alarm cause	Checking method	Corrective action
Exceeds the drive rated load continuous using curve.	Check if the frequency of the operation cycle is too fast.	Increase motor capacity or reduce operation cycle frequency.
Unstable system.	Check whether the acceleration/deceleration time setting is too short.	Increase the setting value of acceleration and deceleration time.

AL.1A Index coordinate undefined

Alarm cause	Checking method	Corrective action
When using the indexing function, you need to execute homing to define the starting point of the indexing coordinates. otherwise, an alarm will be triggered.	Check whether homing has been executed.	<ol style="list-style-type: none"> 1. Before operating the indexing function, make sure execute homing first to avoid this alarm. 2. Use DI:Alm Reset to clear the alarm when alarm occurs. 3. This alarm can also be cleared when Servo ON.

AL.1B Position shift warning

Alarm cause	Checking method	Corrective action
MC_OK signal turns from ON to OFF, you can refer to PD28 description.	When DO: MC_OK is already ON, it may turn OFF when DO: INP turns OFF, The position shift may cause by external force after motor completed positioning.	<ol style="list-style-type: none"> 1. Turn the RES signal ON. 2. Press the Set button at alarm display screen. 3. Turn the power OFF→ON 4. Turn on SON.

AL.1C Early overload warning

Alarm cause	Checking method	Corrective action
The overload duration exceeds the early warning of protection curve.	Check whether the load exceeds the motor capacity.	1. Refer to AL.34 overload 4 alarm instruction.

AL.61 Parameter group of PR is out of range

Alarm cause	Checking method	Corrective action
Parameter group of PR is out of range.	The group setting is out of range when the PR program writes parameters.	Clear the alarm by any of the following solutions: <ol style="list-style-type: none">1. Turn the power OFF→ON2. Press the "SET" button at alarm display screen.3. Turn ON the RES signal.

AL.62 Parameter number of PR is out of range

Alarm cause	Checking method	Corrective action
Parameter number of PR is out of range.	The parameter number setting is out of range when the PR program writes parameters.	Clear the alarm by any of the following solutions: <ol style="list-style-type: none">1. Turn the power OFF→ON.2. Press the "SET" button at alarm display screen.3. Turn ON the RES signal.

AL.63 Parameter value of PR is out of range

Alarm cause	Checking method	Corrective action
The writing parameter value of PR command(TYPE=8) is out of range.	Check whether the writing parameter value of PR command(TYPE=8) is out of range.	Clear the alarm by any of the following solutions: 1. Turn the power OFF→ON 2. Press the "SET" button at alarm display screen. 3. Turn ON the RES signal.

AL.64 Parameter setting of PR is in error

Alarm cause	Checking method	Corrective action
The PR program(TYPE=8) writes the parameter during Servo ON.	The PR program(TYPE=8) writes the parameter during Servo ON or the parameter value is unreasonable	Adjust PR commands and parameters

11. Specifications

11.1 Servo drive standard specifications

Drive Model Type SDC-□□□A2		010	020	040	075	100	
Servo Motor type SME-□□□□		L010	L020	L040	L075	L100	
Motor capacity		100W	200W	400W	750W	1.0KW	
Main circuit power	Input	Voltage 50/60Hz	Single-phase 200~240VAC				
		Permissible voltage 50/60Hz	Single-phase 170~264VAC				
		Permissible frequency	±5%				
	output	Voltage	0~240VAC				
		Current	1.0 A	1.8 A	3.2 A	5.8 A	5.8 A
		Frequency	0~250 Hz				
Control circuit power	Input voltage 50/60Hz	Single-phase 200~240VAC					
	Permissible voltage 50/60Hz	Single-phase 170~264VAC					
	Permissible frequency	±5%					
	Power consumption	30W					
Control method		IGBT-PWM Control(SVPWM)					
Dynamic brake		Built-in(software)					
Protection function		Over current, Under voltage, Over voltage, Overheat, Overload(Electron accumulated heat) , Fan error protection, Pulse command error protection, Encoder error protection, Regenerative error protection, over speed protection, Excessive deviation protection, Serial communication error,serial communication timeout, motor combination error, motor collision error, motor power cable disconnection.					
Feedback encoder		Resolution: single turn 17bit (131072 Pulse), Multi-turn 17bit/16bit					
Communication interface		RS485 (MODBUS), USB					

Drive Model Type SDC-□□□A2		010	020	040	075	100
Servo Motor type SME-□□□□		L010	L020	L040	L075	L100
Motor capacity		100W	200W	400W	750W	1.0KW
Position control mode	Input pulse frequency	Differential input: 500Kpps(low speed) / 4Mpps(high speed) Open collector input: 200kpps				
	Command pulse mode	CCW pulse +CW pulse ; Pulse + Direction ; A phase + B phase				
	Command source	External pulse / internal register				
	Smoothing method	Low-pass filter / Linear / PS-curve				
	Command pulse ratio	Electronic gear ratio A/B times A: 1~4194304, B: 1~4194304 (Limited to :1/50 < A/B < 64000)				
	Deviation excess	±3 revolutions				
	Torque limit	Internal parameter setting				
	Feed forward compensation	Internal parameter setting0~200%				
Speed control mode	Speed control range	Internal speed command 1:5000				
	Command source	Internal register setting				
	Smoothing method	Low-pass filter / Linear acceleration and deceleration curve / S-curve				
	Speed change rate	Load fluctuation 0~100% maximum ±0.01% Power fluctuation ±10% maximum0.01% Ambient temperature fluctuation 0°C~55°C: maximum ±0.5%				
	Torque limit	Internal parameter setting				
	Bandwidth	Maximum 2KHz				
Torque control mode	Command source	Internal register setting				
	Smoothing method	Low-pass filter smoothing				
	Speed limit	Internal parameter setting				

Drive Model Type SDC-□□□A2		010	020	040	075	100
Servo Motor type SME-□□□□		L010	L020	L040	L075	L100
Motor capacity		100W	200W	400W	750W	1.0KW
Digital input/output	Digital Input	Servo on, Forward and reverse rotation limit , Pulse deviation elimination, Torque direction option, Speed command selection, position command selection, Forward and reverse rotation command, proportional control switching, Torque limit switching, Alarm reset, Emergency stop, Control mode switching, E-gear ratio selection				
	Digital Output	Torque limit reached, speed limit reached, Servo ready, Zero speed reached, Target position reached, Target speed reached, Servo alarm, Servo warning, Homing is completed, Overload level reached, Internal position command is completed, Position command overflows, Software positive limit reached, Software reverse limit reached.				
Environment	Temperature	0°C ~ 55°C Storage: -20~65°C (Non-freezing)				
	Humidity	Maximum 90% RH (Non-condensing) Storage: below 90%RH (Non-condensing)				
	Installation site	Indoors (avoid direct sunlight), no corrosive vapor , avoid flammable gases, fumes and dust.				
	Altitude	Below 1,000 m above sea level				
	Vibration	Maximum 5.9m/s ²				
Cooling method		Air convection cooling, IP20.			Fan cooling, IP20.	
Weight(kg)		1.4	1.4	1.4	1.7	1.7

Note: *1 Within the rated speed, the speed change rate calculation is: (rotational speed with no load - rotational speed with full load) / rated speed.

11.2 Interface and out dimensions of the servo drive

DIMENSIONAL

MODEL	W	W1	H	H1	D	D1	S
SDC010A2	51	38	162	150	164	14	5.5
SDC020A2							
SDC040A2							
SDC075A2							
SDC100A2							

11.3 Dimensions of the servo drive

SDC-010A2~~~SDC-100A2 (100W~1KW)

Note: Models below 400W(inclusive) have no fan.

Unit[mm]

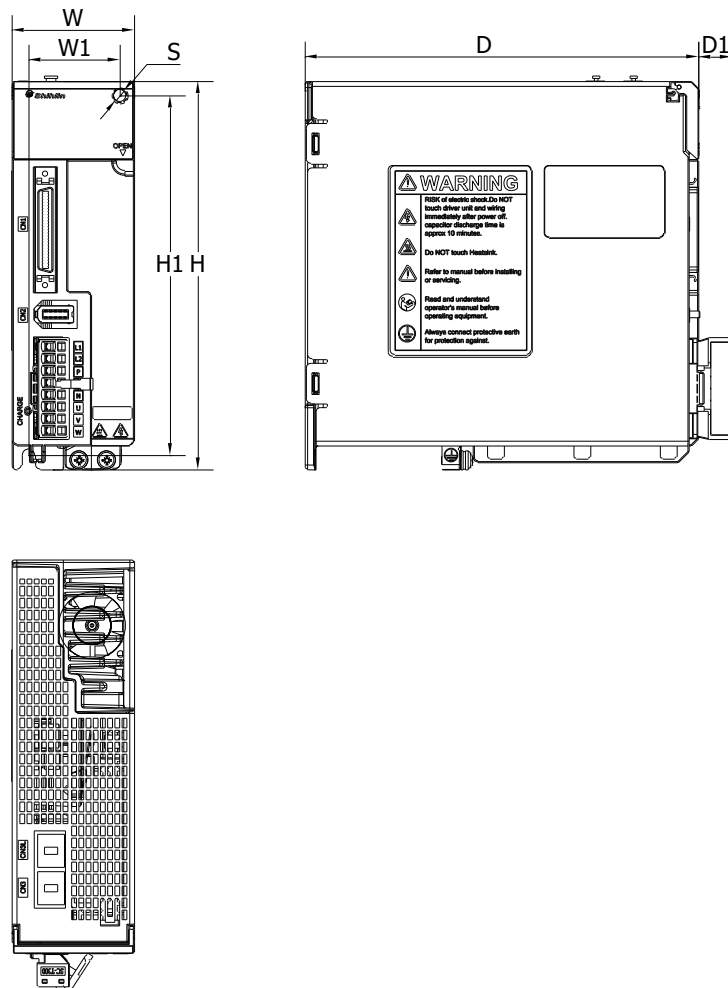

★ Dimensions of the servo drive may be updated without prior notice

11.4 SME series servo motor general specification

11.4.1 Standard Specification of Low Capacity Servo Motor

□□□□ Motor type	--	L010	L020	L040	L075	L100
Flange number	mm	□40	□60		□80	
Rated power	W	100	200	400	750	1000
Rated torque(Note 1)	Nm	0.32	0.64	1.27	2.4	3.2
Maximum torque	Nm	0.96	1.92	3.81	7.2	9.5
Rated speed	rpm	3000				
Maximum speed	rpm	6000				5000
Rated current	A	0.85	1.7	2.8	5.8	5.5
Maximum current	A	2.7	5.2	9.0	18.5	18.2
Rotor inertia J ($\times 10^{-4}$) (Note 2)	kg-m ²	0.0518 (0.0523)	0.161 (0.178)	0.277 (0.294)	1.07 (1.11)	1.89 (1.91)
Power at continuous rated torque	kw/s	19.6	25.2	58.5	53.3	53.6
Mounting aluminum plate size	mm	250 x 250 x 6				
Insulation class	--	CE(B) & UL(A)				
Insulation resistance	--	100M Ω @ DC500V				
Insulation strength	--	60sec @ AC1500V				
Encoder resolution	--	Resolution 17bit (131,072 Pulse)				
Motor structure(Note 3)	--	Fully closed and Air convection cooling(IP rating IP65)				
Vibration grade	--	V-15				
Operation environment	temperature	--	0°C ~ 40°C (Non- freezing) / Storage:-15°C ~ 70°C (Non- freezing)			
	humidity	--	Below 80%RH(Non-condensing) Storage : below 90%RH(Non-condensing)			
	Altitude	--	Below 1,000m above sea level			
	Environment restrictions	--	Indoors (avoid direct sunlight), no corrosive vapor , avoid flammable gases, fumes and dust.			
	Vibration resistant	--	5G			
Axial allowable load(Note 5)	Fd	mm	20	25	35	
	radial loading Fr	N	68.6	245	392	

	axial loading Fa	N	39.2	98	147		
Brake specification (Note4)	Input voltage	V	DC 24V ± 10%				
	Brake holding torque	Nm	0.3	1.3	2.5	3.2	
	power consumption	W	7.2	7.6	8	10	
	Current consumption	A	0.3	0.32	0.33	0.42	
	impedance @20°C	Ω	80	75.4	72	57.6	
	Brake release time	ms	40	60	60	60	
	Brake close time	ms	20	40	40	40	
□□□□Motor type		--	L010	L020	L040	L075	L100
Motor weight(Note 2)		Kg	0.49 (0.71)	0.89 (1.27)	1.28 (1.66)	2.28 (3.02)	3.55 (4.36)

Note 1: In the vertical lift or reciprocating mechanism application, please make sure the average load rate is below 75%. (refer to P. 292 for S-T curve)

Note 2: () is the rotor inertia and weight with electromagnetic brake.

Note 3: The motor IP65 protection test is for the motor body, excluding the output shaft and the connector itself.

Note 4: The electromagnetic brake is used for holding when the mechanism stops, and cannot be used for braking during operation.

Note 5: refer to Note 5 in Section 11.4.2.

11.5 Motor dimensions

11.5.1 Dimensions of 3000 RPM motor

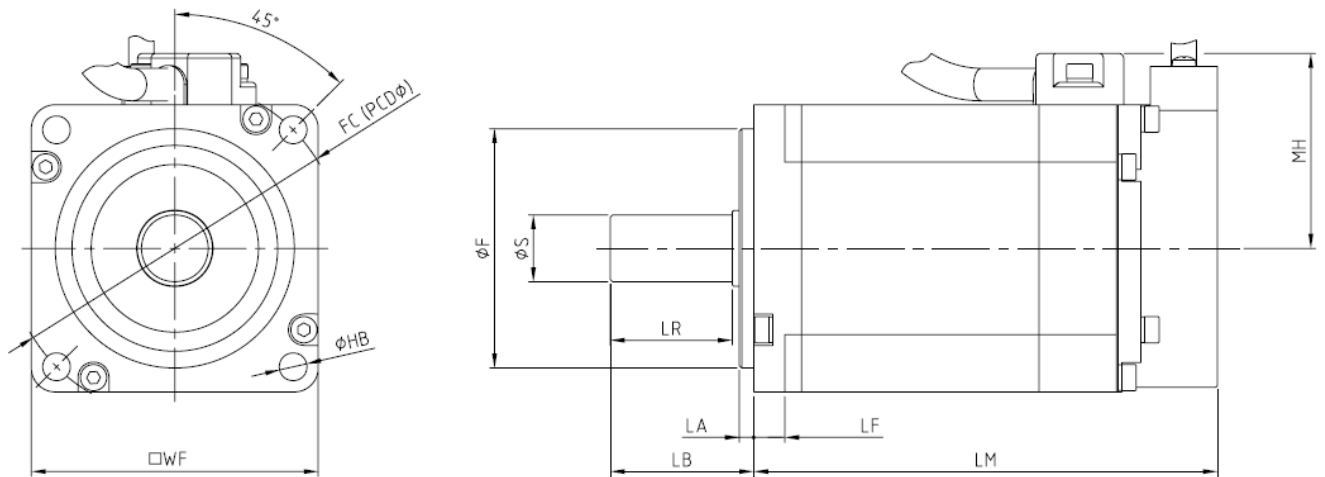

Model	Item Dimension(mm)										
	WF	ψS	ψF	LA	LB	LF	LR	MH	LM	FC	HB
SME-L010(B)	40	$\phi 8_{-0.009}^0$	$\phi 30_{-0.03}^0$	2.5	25	5.5	21.2	32	97.8 (132.5)	46	2-ψ4.5
SME-L020(B)	60	$\phi 14_{-0.011}^0$	$\phi 50_{-0.03}^0$	3	30	6.5	25.5	42	94.2 (129.2)	70	4-ψ5.8
SME-L040(B)									114.2 (149.2)		
SME-L075(B)	80	$\phi 19_{-0.013}^0$	$\phi 70_{-0.03}^0$	3	40	7.5	35.3	52	119.2 (158.2)	90	4-ψ6.6
SME-L100(B)									159.2 (203.5)		

LM ():Length of model with brake

11.5.2 Dimensions of 2000 RPM motor

There is no 2000 rpm motor in SDC series currently.

11.5.3 Dimensions of servo motor keyway

D type keyway applicable model: L010(B)

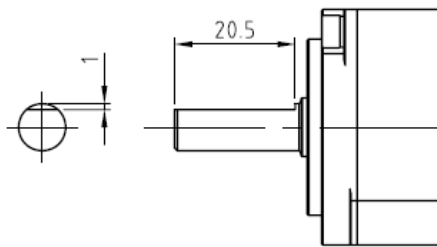

General keyway

Model	Dimensions(mm)					
	QL	QK	W	T	U	Y
L020(B) \ L040(B)	3	20	$5 \begin{smallmatrix} 0 \\ -0.03 \end{smallmatrix}$	5	3	M4xdepth15
L075(B) \ L100(B)	5	25	$6 \begin{smallmatrix} 0 \\ -0.03 \end{smallmatrix}$	6	3.5	M5xdepth20

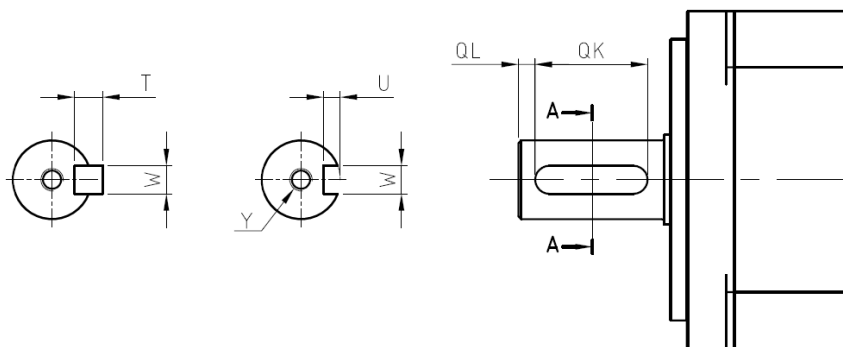

11.6 Electromagnetic Interference Filter (EMI Filter)

To comply with EMI directive of EN specification, it is recommended to use the following recommended filters:

Servo drive	Recommended filter
SDC-010A2□	NF312C5/05
SDC-020A2□	
SDC-040A2□	NF312C10/05
SDC-075A2□	NF312C20/05
SDC-100A2□	

- ★ Filter is optional purchase item.
 - ★ The use of the filter needs to consider the site conditions whether there is electromagnetic compatibility interference before installation.
- The following schematic diagram describes the wiring of an EMC filter and the SDC servo drive

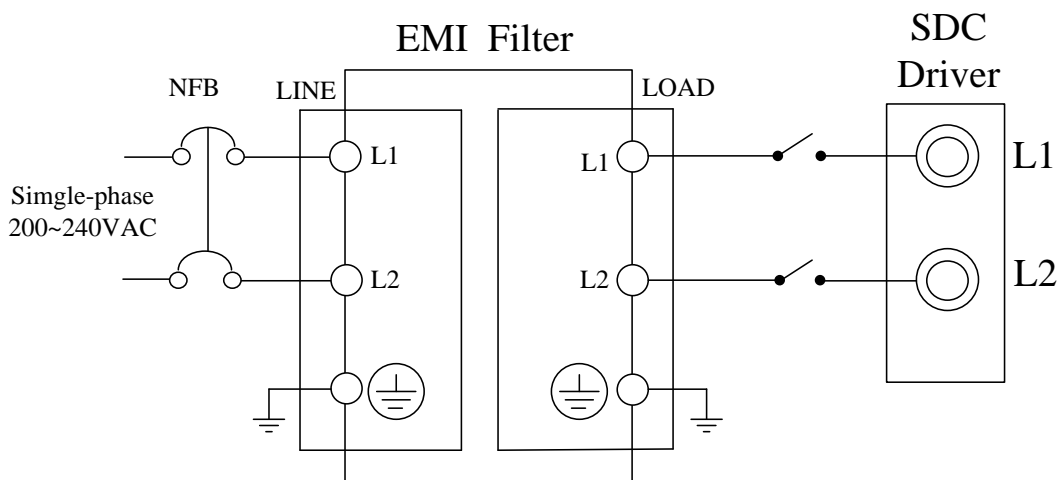

- ★ Ground the EMI Filter.

11.7 EMI interference countermeasure

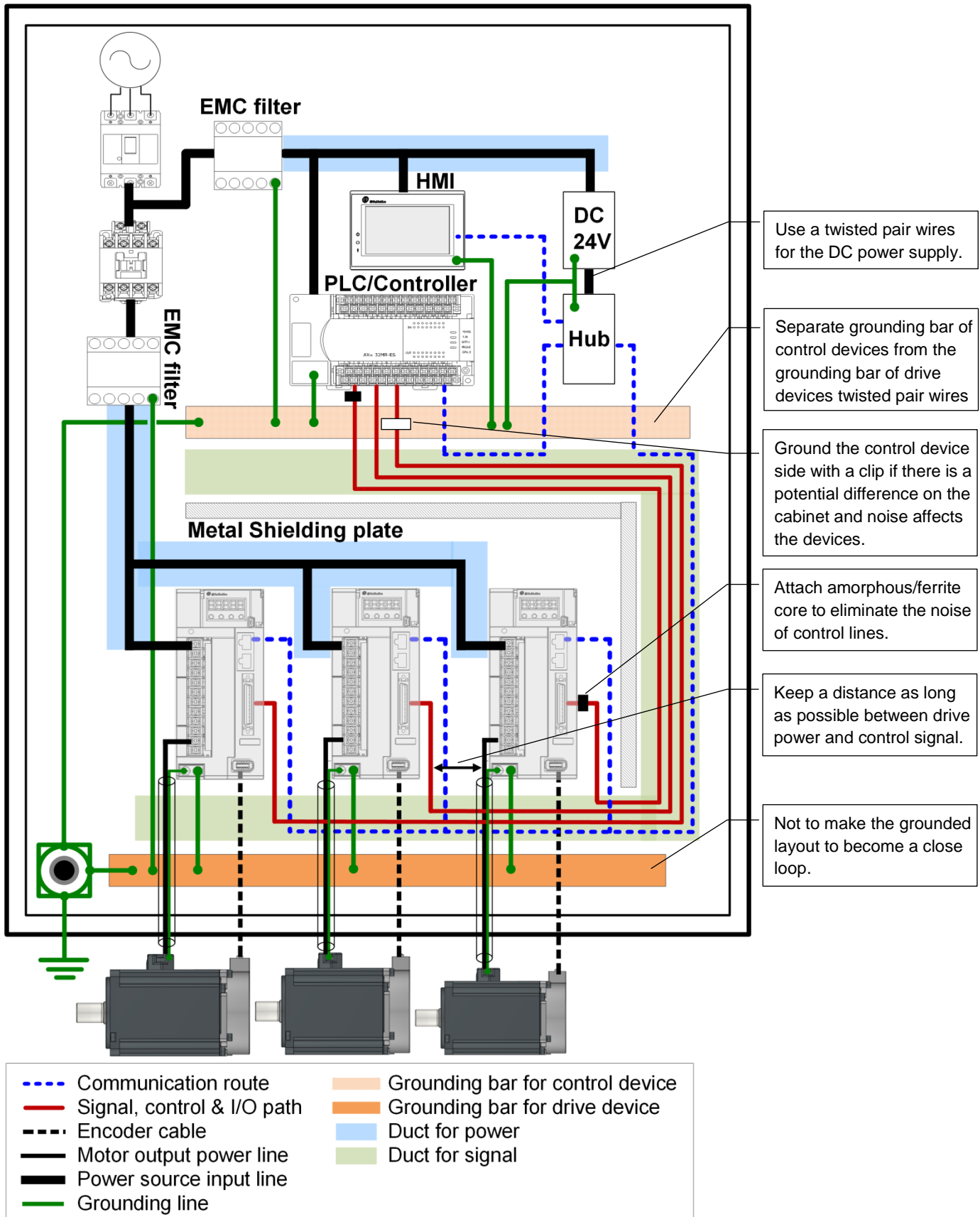

Recommended rules of wirings inside control cabinet

1. Use a metal cabinet. The radiated noise will be suppressed and the grounding will be stabilized.
2. The installation panel (inner panel) of the cabinet must be plated to have sufficient grounding for the devices, and be sure to connect the installation panel to the grounding terminal of the cabinet.
3. Ensure a good conductivity between the door and the cabinet. Connect the door and the cabinet with the rectangular wire. The shielding gasket on the door must be conductive processed.
4. The EMC filter and the servo drive should be installed on the same metal panel, and the wirings between them should be as short as possible.
5. The metal case of the servo drive and EMC filter must be screwed to the metal panel of the control cabinet, and the fixed point must ensure a good conductivity. (The paint on the metal plate should be scraped off)
6. Use the cable with shielding (double shielding is recommended) for motor power output usage. If a P-clip or a U-clip is applied, ensure to be grounded it with the maximum contact area. (See the illustration below)
7. Isolate the control devices and the drive devices with a metal shielding plate.
8. Applied occasion of ferrite core or amorphous core:
 - a. Power input cables of the control devices
 - b. Motor power output cables
 - c. Signal, control, I/O cables
9. The impedance is proportional to the square of windings on the ferrite core or the amorphous core. Pass through multiple times (three passes is better) if possible.
10. Keep the control cables from the power cables as far as possible. And prevent a parallel layout between them.

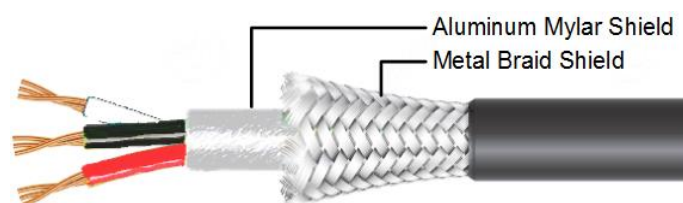

Cable with 2 layer shielding

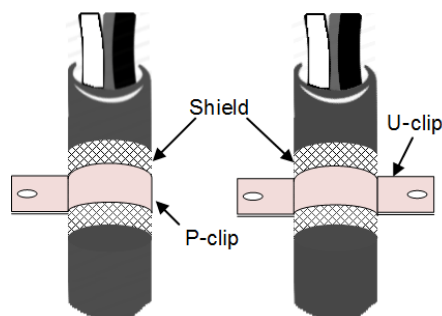

Example of P-clip and U-clip

12. Features

12.1 Motor T-N Curve/S-T curve

- The motor feature of single-phase 220V power supply: the torque feature will be reduced if the voltage is insufficient.

【SME-L010】

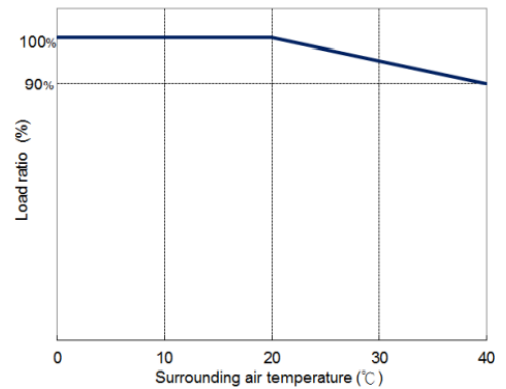
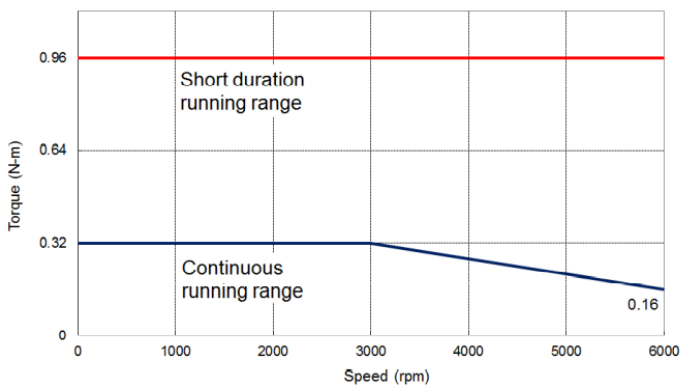

【SME-L020】

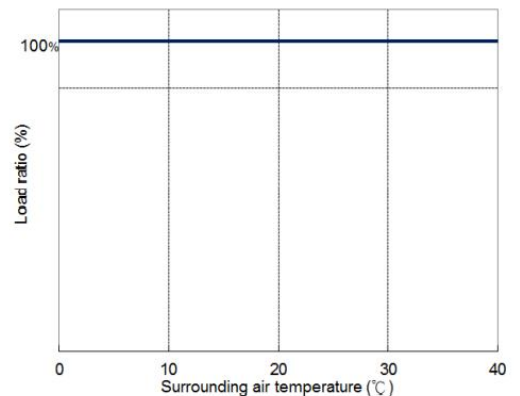
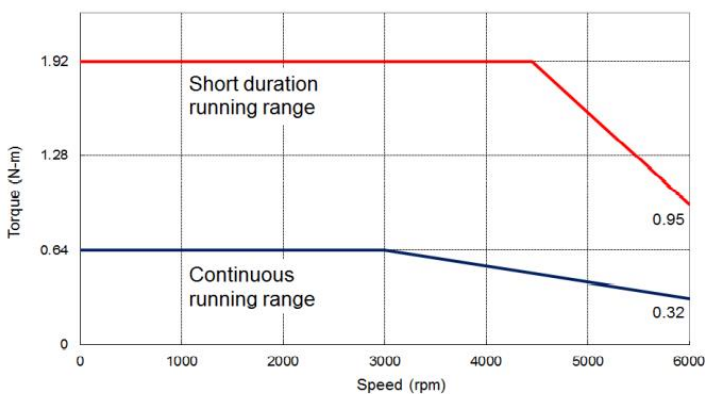

【SME-L040】

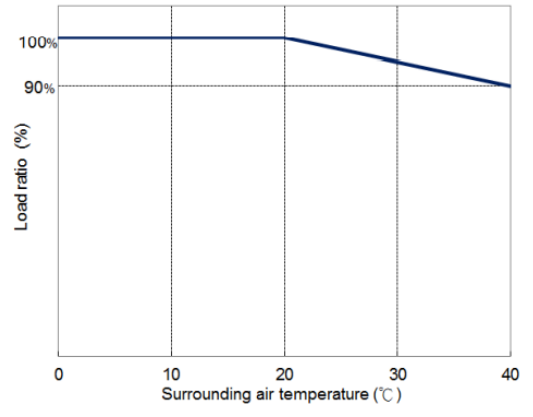
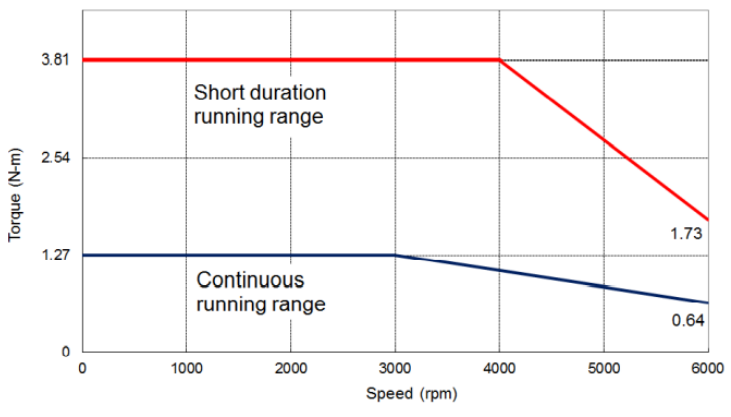

【SME-L075】

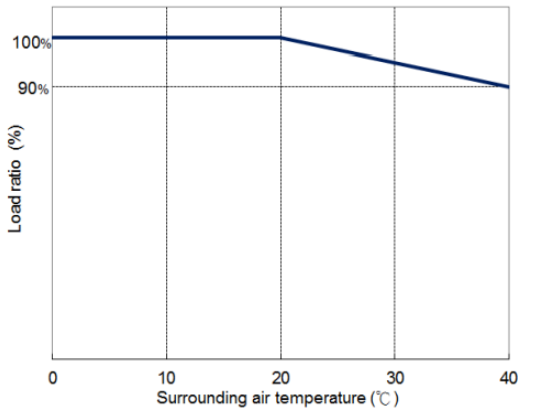

【SME-L100】

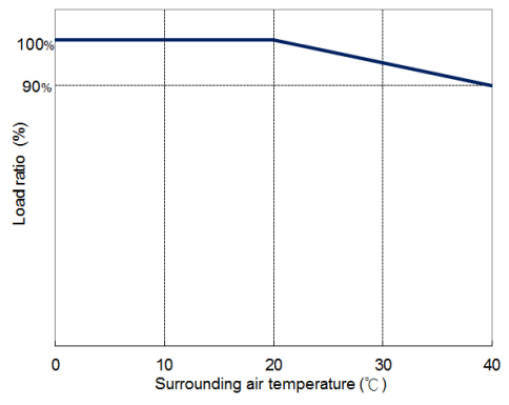
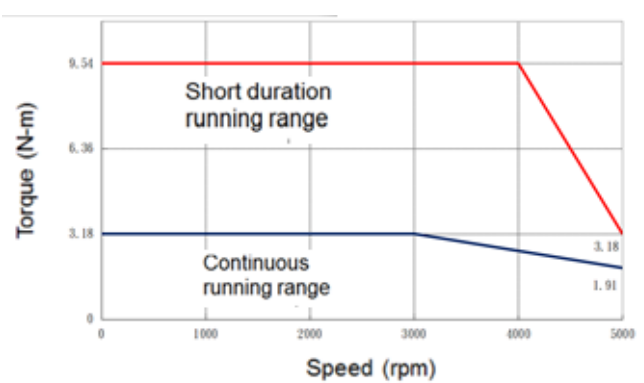

★ This feature is applicable for single-phase 200~240V power supply.

12.2 Overload features

Overload protection is to prevent the servo motor from operating under overload conditions.

Causes of overload as follows:

- (1).The inertia ratio is too large.
- (2).Acceleration and deceleration time setting cannot be reached theoretically when loading.
- (3).The motor's operating torque exceeds the rated range and the operating time is too long.
- (4).Incorrect servo gain setting causes resonance in the motor and yet the motor keeps running.
- (5).Incorrect wiring of the power and encoder cables.

If the operating servo motor may exceed the rated torque during operation, you can refer to the Graph of Load and Operating Time as follows:

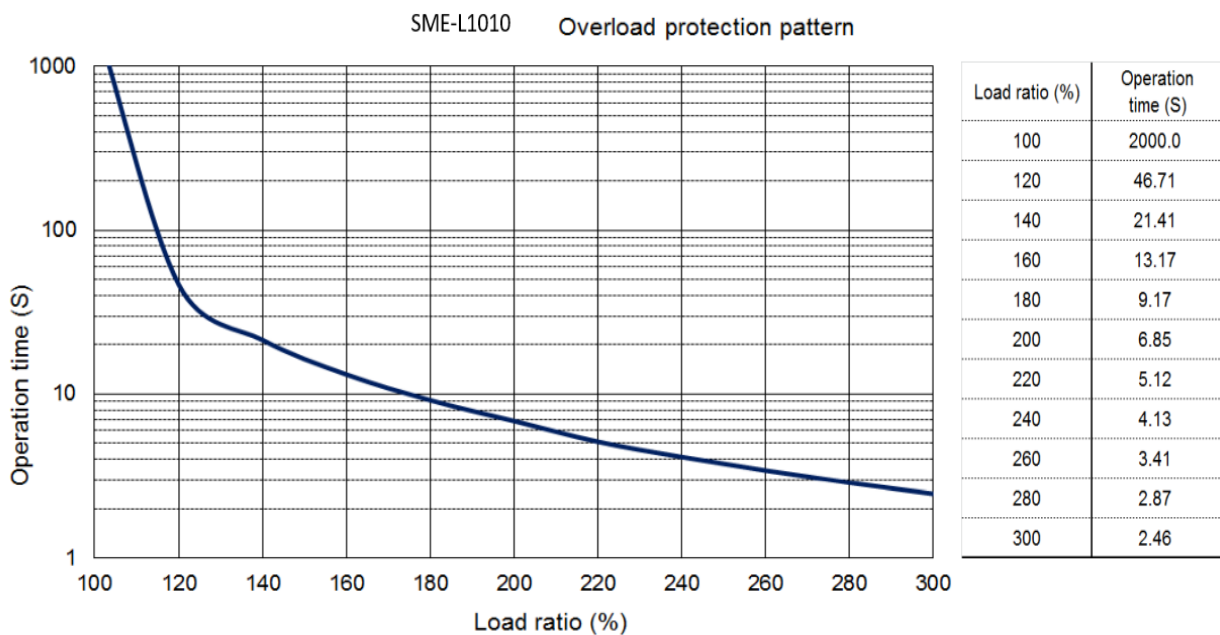

When the load reaches 300%, the operation time is 2.46 seconds.

SME-L020-075 · Overload protection pattern

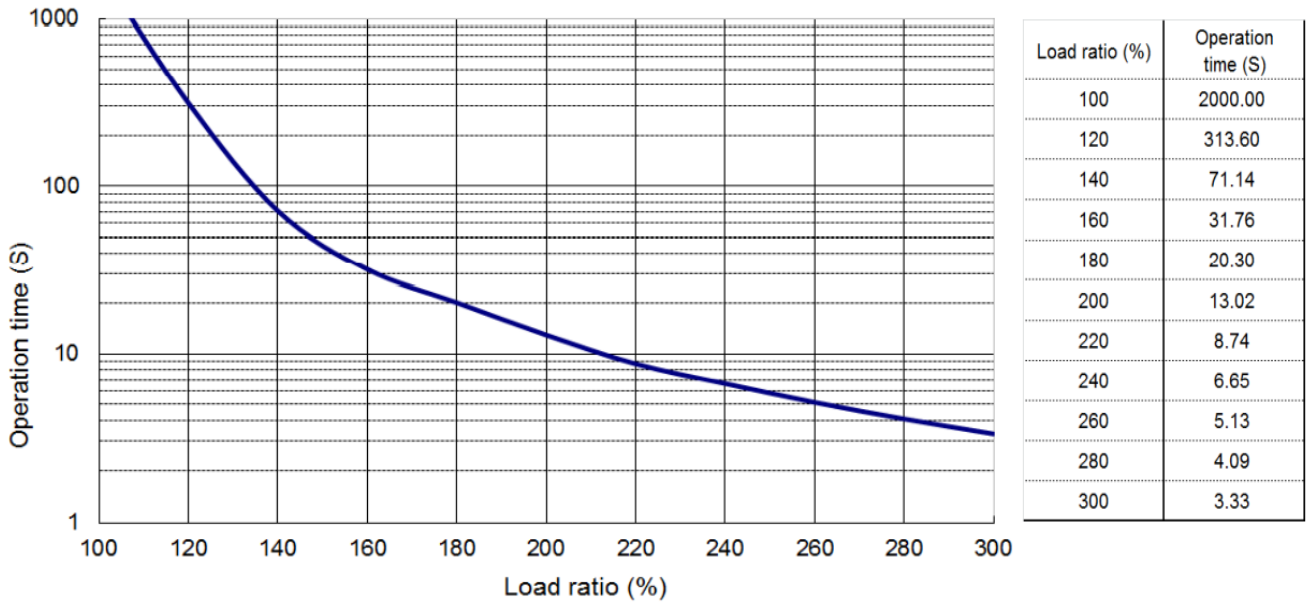

When the load reaches 300%, the operation time is 3.33 seconds.

SME-L00 · Overload protection pattern

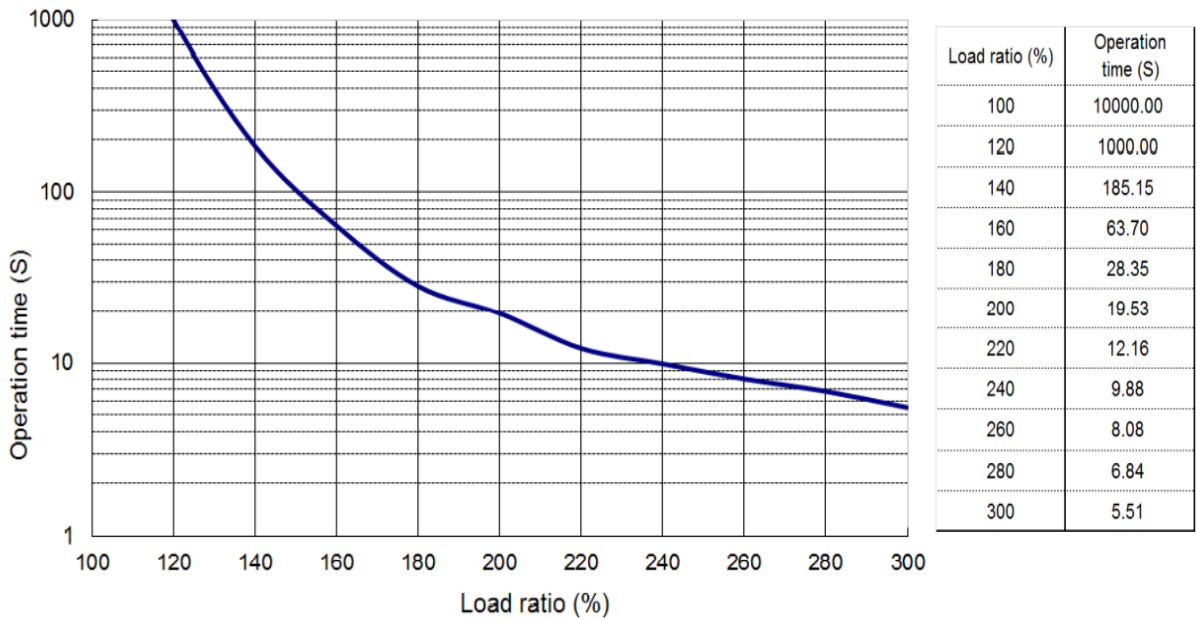

When the load reaches 300%, the operation time is 5.51 seconds

13. Absolute Servo System

Absolute servo system includes servo drive, absolute servo motor and absolute encoder cable (including battery box). The absolute position detection system does not store the data in the PLC controller, but detects the absolute position of the machine and store the data by battery power. Therefore, as long as the origin is set during installation, operation can be easily restarted even if power outage or breakdown.

If the drive has enabled the relevant parameters of the absolute system, an absolute servo motor must be used. If the incremental servo motor is used, an alarm AL.24 will occur.

The absolute motor model description is as follows:

SME-□□□□ΔΔN□□□



—N: Absolute servo motor

Note	When [Absolute position is lost] or [Absolute position overflows] occurs, the origin setting needs to be performed again.
	Please put the battery in the battery box before using it to prevent unexpected factors such as battery is short-circuited.
	When using an absolute servo motor, please make sure that the motor speed is lower than 50 rpm at the moment of power-on.
	After the drive is powered off, the speed should not exceed 50 rpm in battery mode.

Focus	The absolute position will disappear when the battery is removed, Make sure to set the origin before running
-------	--

Restricted items:

The absolute position system is not suitable in the following conditions

- (1) Speed control mode and torque control mode.
- (2) In switching control mode.
- (3) In rotating axis, infinite operation cycle positioning.
- (4) Change the electronic gear ratio after setting the origin.
- (5) Use error code output.

How to replace the battery

- (1) When the drive displays alarm AL.2D, which means the voltage is too low, please replace the battery immediately to avoid data loss.
- (2) When the battery voltage is less than 2.45V, AL.2A will occur and the motor position data has been lost. , the homing must be performed after the battery is replaced.



Attention!!!

It is recommended to replace the battery when the drive is powered on and the motor is stopped to avoid absolute position data loss.

System initialization

- (1) Install absolute motor and battery.
- (2) Set PA28 to "1", set the absolute system, and then restart the drive.
- (3) [AL.2A Absolute encoder abnormal 1] alarm will occur after power-on, you can clear the alarm as follows
- (4) Turn the power OFF→ON to clear the alarm
- (5) Absolute position loss [AL.2C Absolute Encoder error 3] alarm will occur after power-on, and it is necessary to reset the absolute system origin to clear this alarm. The method is as follows
- (6) (a) Set PA29 = 1, and then the coordinate initialization is completed.
(b) In Pr mode, the origin return action is performed. When the action is completed, the absolute coordinate system is reset.

Cautions:

In the absolute system, the position movement has certain restrictions. When the number of motor revolution exceeds the range of -32768 ~ +32767, an alarm AL.29 will occur.

Pulse number calculation

The motor's maximum countable number of revolutions range is -32768 ~ +32767. If it exceeds this range, an overflow (AL.29) alarm will occur. According to the motor encoder type, the motor single-turn pulse value is 131072 (17bit)

The number of revolutions and pulse of the absolute servo system can be access through communication or DI/DO. The total pulse value is calculated as follows.

Total pulse value = r (number of revolutions) x 131072 + pulse number (0~131071)

If the motor has rotated 10 cycles with 50000 pulse, the total pulse value is as follows according to the above calculation:

The total pulse value = 10 x 131072 + 50000
= 1360720(pulse)

Method of accessing absolute motor position

(1)To access the absolute position with communication

For general conditions, you can use the status monitoring communication parameter table in section 9.4 to read the data. Generally, it is recommended to use the "Motor Feedback Pulse Number (before electronic gear ratio)". The following is a simplified table.

Communication address	Item	Data length
0x0000	Motor feedback pulse number (after E-gear) [pulse]	2word
0x0024	Motor feedback pulse (before E-gear) [pulse]	2word

(2)Use PLC DIO communication to access absolute position

Use PLC DIO communication to access absolute position, you can refer to the descriptions in sections 13.1 and 13.2.

(3)Set the drive parameter to return position

The parameter PA30 can also be written through communication, and the drive will update the current encoder status and absolute motor position. When PA30 = 1, the deviation value will not be cleared when reading the position value; if PA30 = 2, the deviation value will be cleared when reading the position value.

Because when the servo motor is stopped, a slight position correction will performed. To avoid the difference between the absolute coordinate value and the actual position of the motor, you can clear the position deviation when reading the coordinate. When the drive updated the encoder status and the absolute position of the motor, the drive will automatically reset PA30 to 0, which means that the host computer can read the parameter data.

If the encoder status displays "absolute position is lost" or "absolute revolution number overflows", the accessing absolute position is invalid, and the coordinate initialization or homing must be performed again.

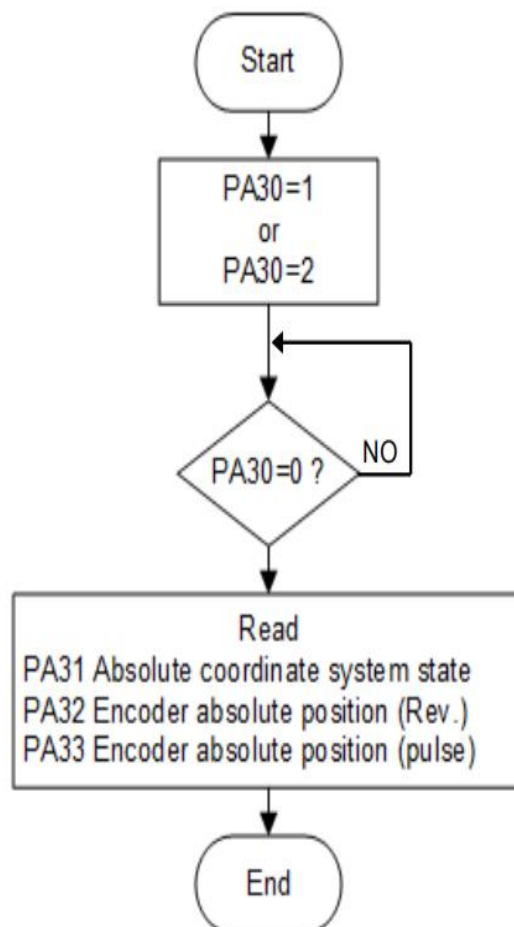

13.1 Mitsubishi Absolute Position Detection System

This section mainly introduces the use of Mitsubishi PLC with SDC servo for DIO communication to read absolute position.

13.1.1 Signal description

When transmitting absolute position data, the signal of CN1 terminal will be changed.

Signal	Code	CN1 Pin	Function	I/O
ABS Transmission mode	ABSM	User-defined	To activate ABSM and start ABS communication mode. Enable ABSR, ABST, ABSB0, ABSB1.	DI-x
ABS request	ABSR	17	To turn ABSR ON during accessing ABS data in ABS communication mode.	DI-4 (fixed)
ABS data as 0	ABSB0	43	low 2 bit of ABS data.	DO-3 (fixed)
ABS data as 1	ABSB1	44	high 2 bit of ABS data.	DO-4 (fixed)
ABS ready	ABST	42	Turn ABST on when ABS is ready in ABS communication mode.	DO-2 (fixed)
ABS origin setting	ABSC	User-defined	Origin data is cleared when ABSC is ON.	DI-x
ABS position lost	ABSV	User-defined	ABSV is ON when absolute position is lost.	DO-x

For detailed wiring, please refer to the following wiring example.

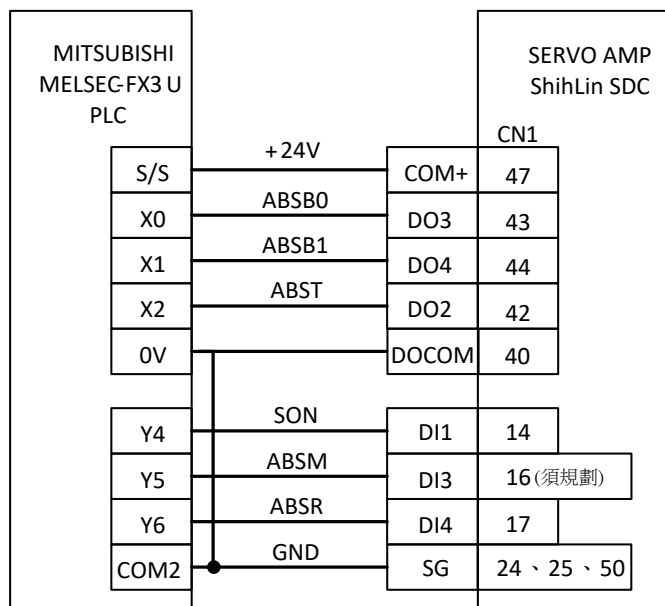

13.1.2 Startup procedure

- (1) Install absolute motor and battery

Parameter setting

- (2) PA28 is set to "1" which is absolute system setting.

Set PA34 to "□□□1", then restart the drive to set the Mitsubishi absolute position detection system.

And then restart again to activate the parameter setting.

- (3) [AL.2A Absolute encoder error 1] Alarm release

When the battery is replaced and the power is turned on for the first time, an "AL.2A Absolute Encoder error 1" alarm will occur. You can restart the power to release the alarm.

- (4) Absolute position loss [AL.2C Absolute encoder error 3] Alarm release

When the absolute system is powered on for the first time, an alarm of "AL.2C Absolute Encoder error 3" will occur. You can set PA29 to "1" or perform coordinate initialization to clear the alarm.

- (5) Absolute position data transmission confirmation

Turn on SON, and the absolute position data starts to be transmitted to the PLC. After normal transmission of ABS data.

(a) RD (ready) is ON.

(b) ABST (ready) of PLC is ON.

(c) If [ABS timeout alarm] occurs, refer to section 10. 2.

- (6) Homing

Homing in the following conditions

(a) When setting absolute system.

(b) When changing servo drive.

(c) When changing servo motor.

(d) When absolute position loss [AL.2C Absolute encoder error 3] alarm occurs.

When setting an absolute position system, you can establish an absolute coordinate position through the origin setting. If you run the motor without establishing the origin, unexpected actions may occur.

13.1.3 Absolute position data transmission protocol

(1) Data transmission procedure

After the power is turned on, the PLC will access the current position of the drive when SON is on.

Focus	If turn SON on when ABSM is off, the main power circuit will not switch on.
-------	---

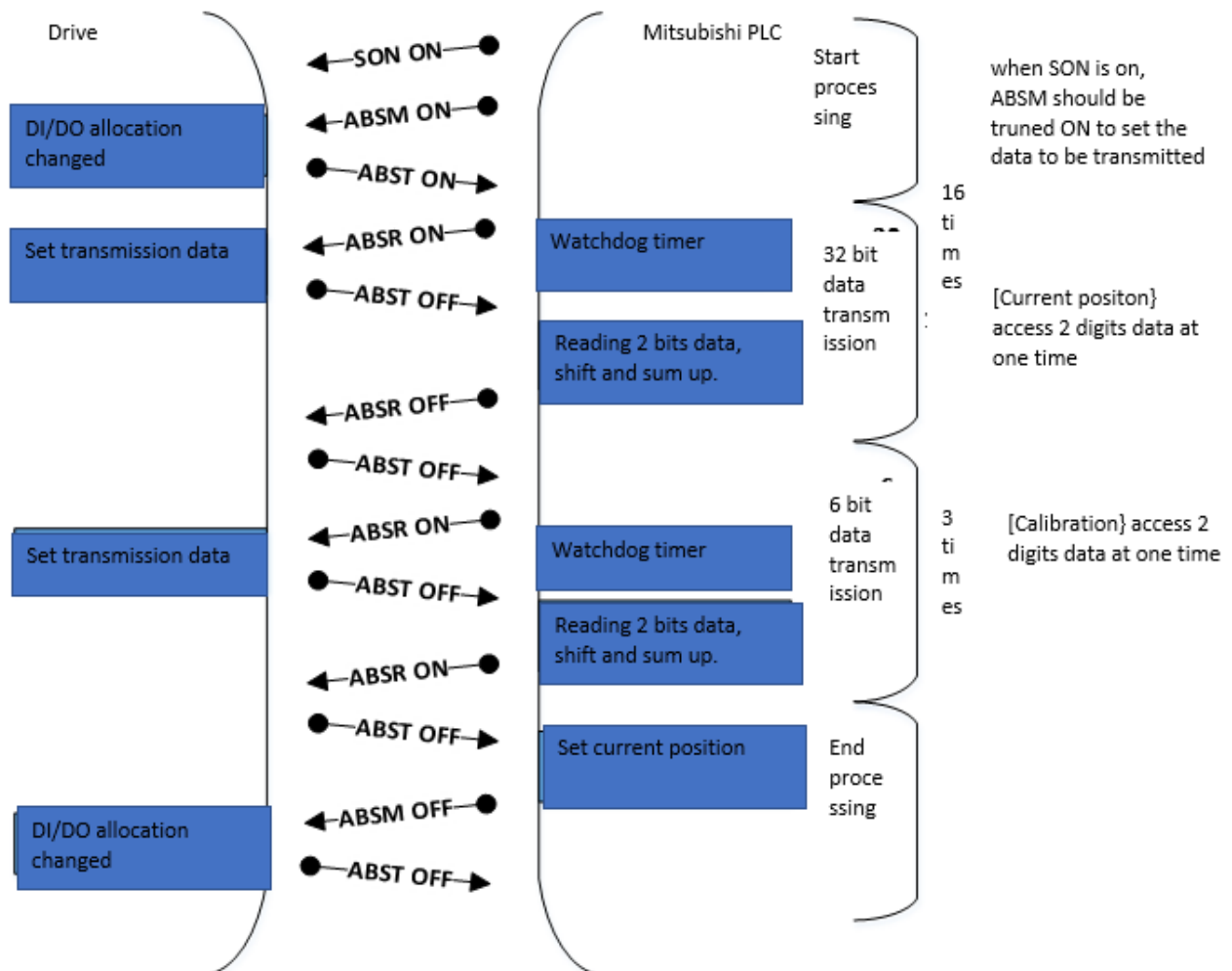

(2) Transmission method

In the absolute position detection system, when SON is turned on, ABSM must be turned on to transmit the current position of the drive to the host controller. If ABSM is turned off, the main power circuit will not switch on.

(a) Sequence chart

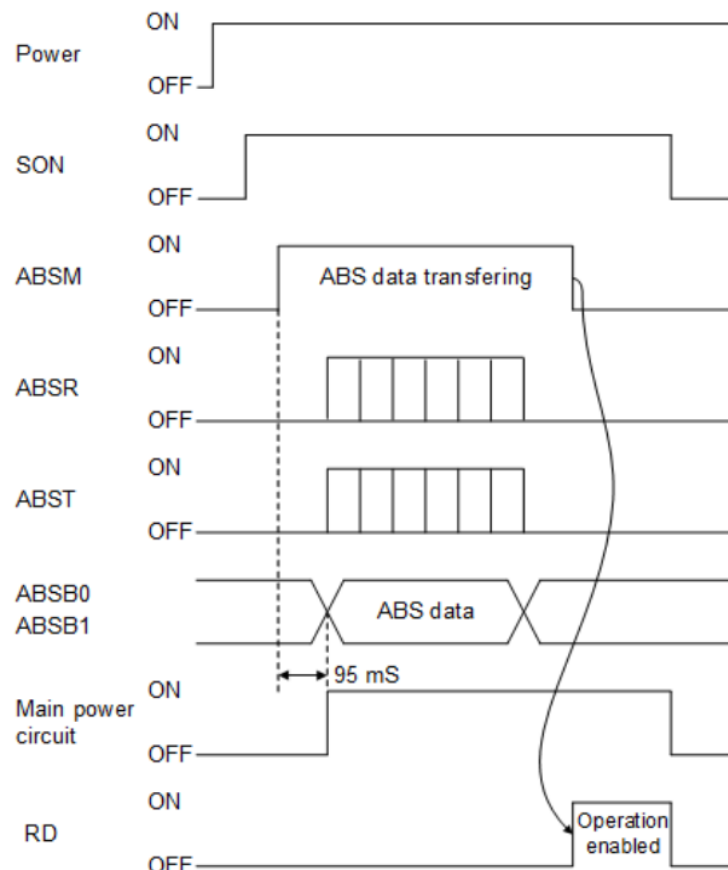

- (1) After the ABS data transmission is completed, RD turns on by ABSM OFF. When RD is on, ABSM ON is disabled.
- (2) Even if SON is turned on, the main circuit will not be switched on until the ABSM is turned on. When an alarm occurs, the ABSM is disabled; when a warning occurs, the ABSM is enabled.
- (3) During ABS transmission, when ABSM is OFF, the ABS transmission mode is interrupted and [AL.17 ABS timeout warning] occurs.
- (4) During ABS transmission, [AL.17 ABS timeout warning] will also occur when SON OFF, RES ON or EMG OFF.

- (5) The output signal functions of ABST, ABSB0 and ABSB1 will change according to the status of ABSM.

CN1 pin number	Output signal	
	ABSM OFF	ABSM ON
43	WNG Warning/ CMDOK internal position command is completed	ABS Data bit 0
44	TLC torque limit control	ABS data bit 1
42	ZSP zero speed is detected.	ABS data ready

- (6) When the main circuit is on, ABSM is not allow to enable. If you want to send data again, you must turn off the SON and wait for the main circuit to turn off for more than 20mSec.

(b)Detailed description of absolute position data transmission timing

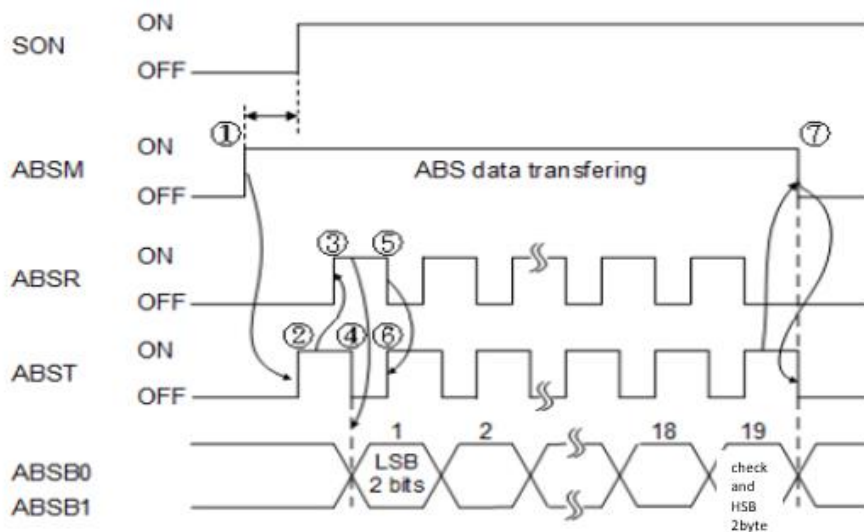

After the ABSM is turned on, , the ABS servo turn-on timeout will occur if the SON is not turned on within 1 second, but the transmission will not be impacted. If you want to clear the ABS servo on warning, you can just turn the SON on. The detailed timing diagram is as follows:

- (1) The PLC turns on ABSM and SON.
- (2) When entering the ABS transmission mode, ABST (data ready) is ON after the driver calculates the absolute position,

(3) Transmission error

[AL.17 ABS timeout warning]

In the ABS transmission mode, a time-out warning will occur in the following conditions. Alarm will released automatically when ABSM is turned on.

(1) ABS request off-time timeout check.

After the ABST is turned on, if the ABSR data requested signal is not turned on within 5 seconds, [AL.17 ABS timeout warning] will occur.

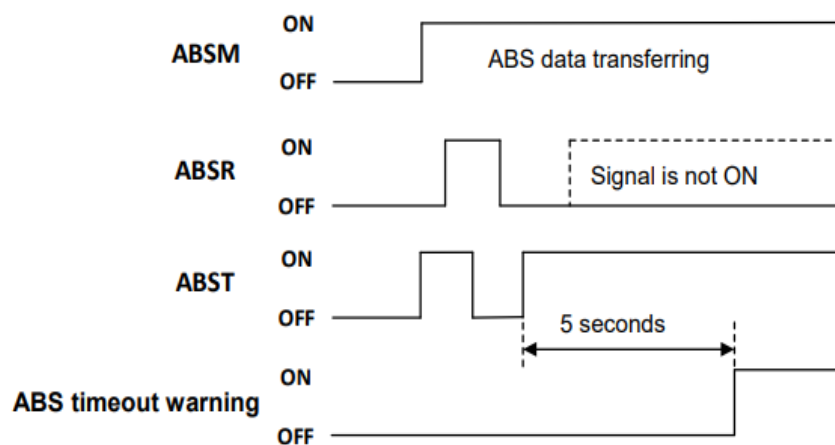

(2) ABS request on-time timeout check.

After the ABST is turned off, if the ABSR data requested signal is not turned off within 5 seconds, [AL.17 ABS timeout warning] will occur.

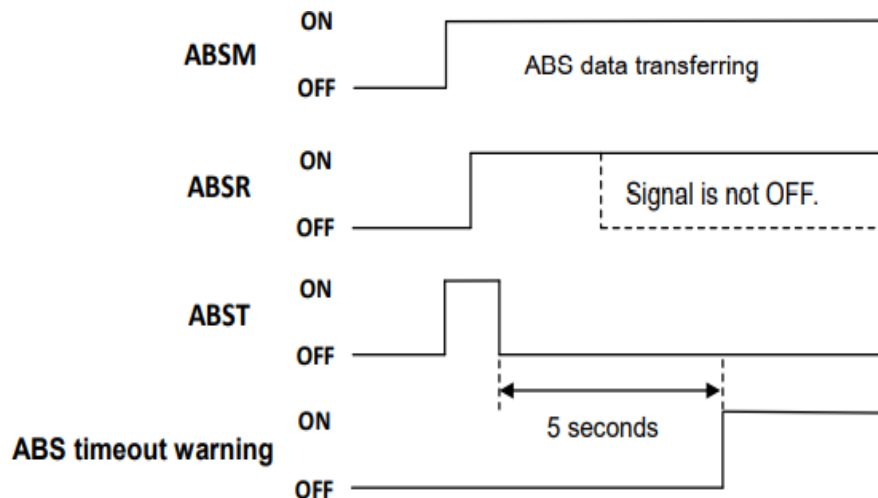

(3) Timeout check after the ABSM transmission mode ends

After the ABS data transfer is completed and ABST is turned on, if the ABSM transmission mode signal is not turned off within 5 seconds, [AL.17 ABS timeout warning] will occur.

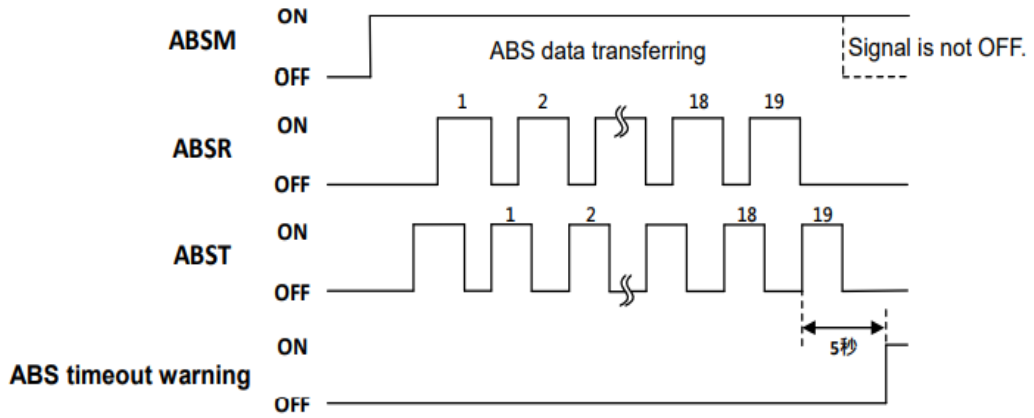

195

(4) ABSM signal check in ABS transmission mode

If the ABSM signal is turned off when the ABS transmission is not completed, [AL.17 ABS timeout warning] will occur.

This example is to turn ABSM OFF before the 19th ABST data ready is turned on.

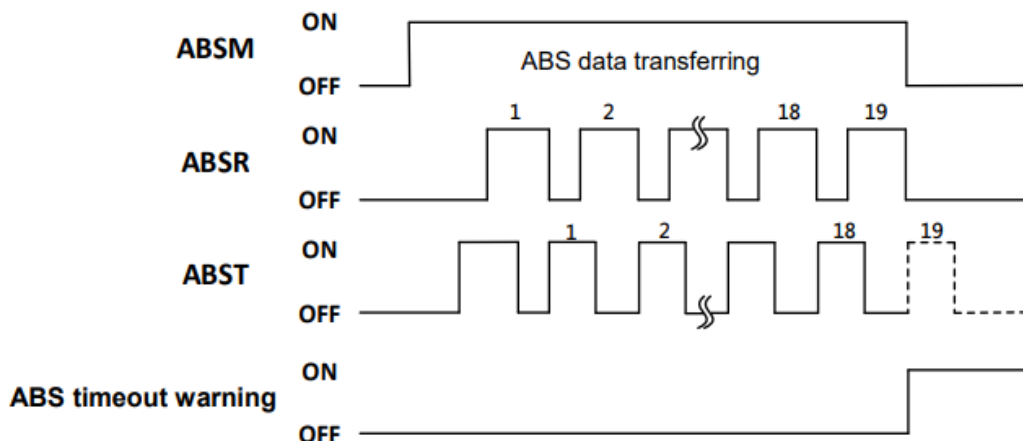

(5) SON signal check in ABS transmission mode

If the SON signal is turned off when the ABS transmission is not completed, [AL.17 ABS timeout warning] will occur. This example is to turn SON OFF before the the 19th ABST data ready is turned on.

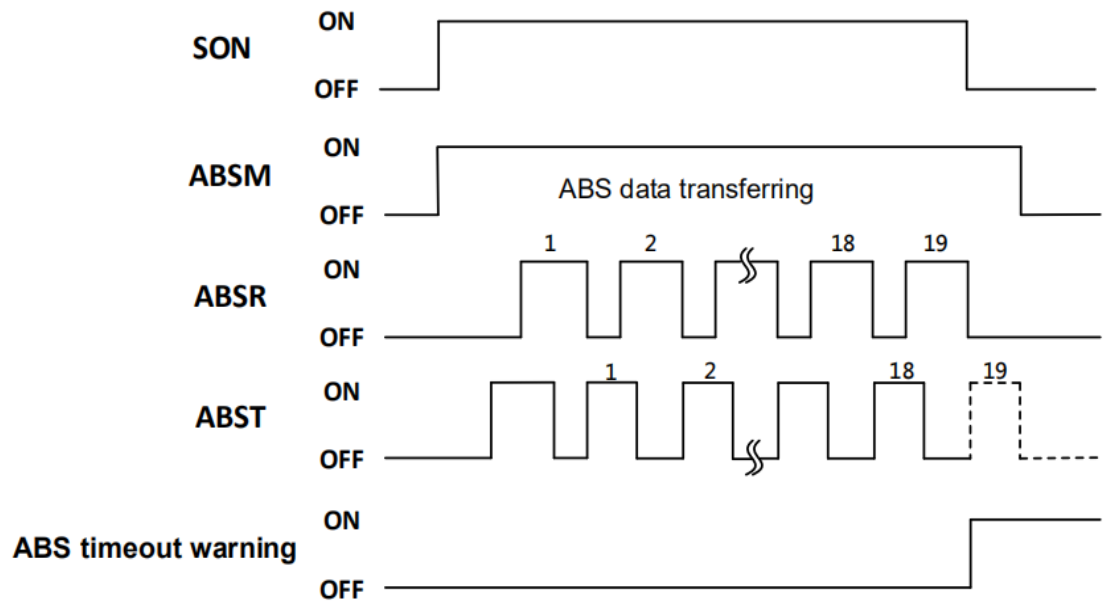

Checksum error

When the checksum is wrong, the ABS data transmission will start again. After the ABSM is closed for 10mSec, the SON will close, and it will take 20mSec to restart.

After re-testing 3 times, an ABS checksum error will occur if normal communication is invalid.

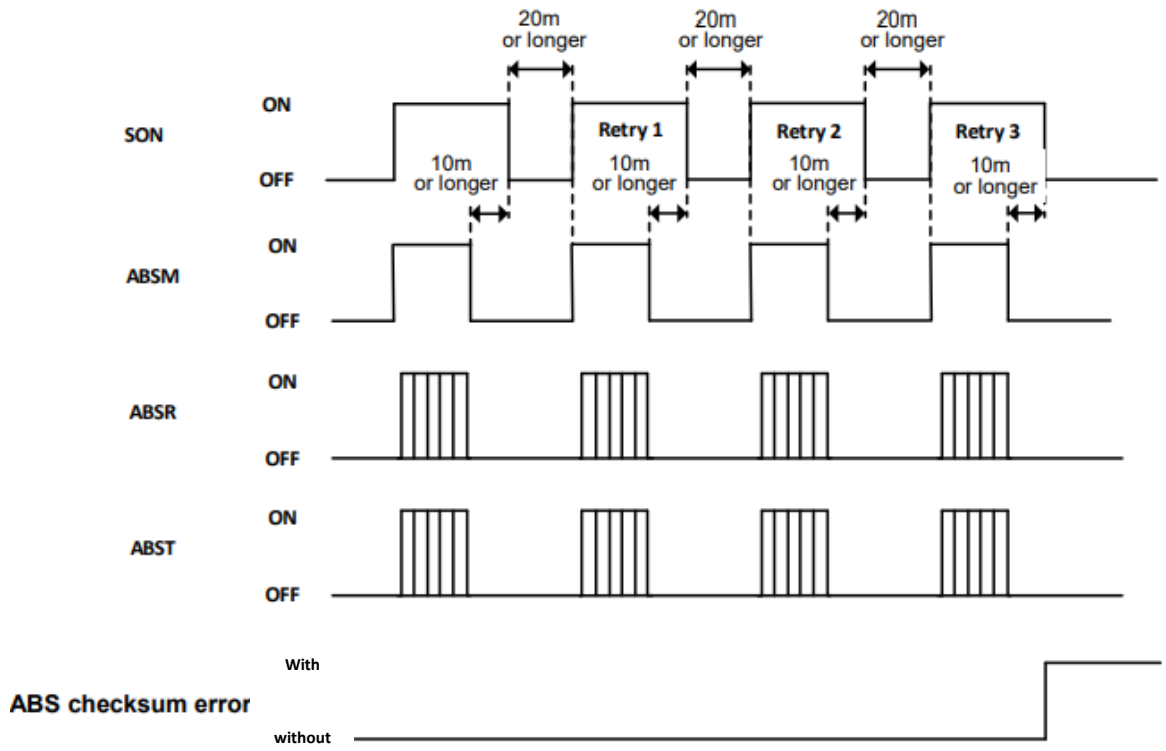

Clear alarm

When an alarm occurs, SON will be OFF. ABSM is not received when there is an alarm; ABSM can be received when the alarm is cleared. ABSM can be turned on after the alarm is cleared.

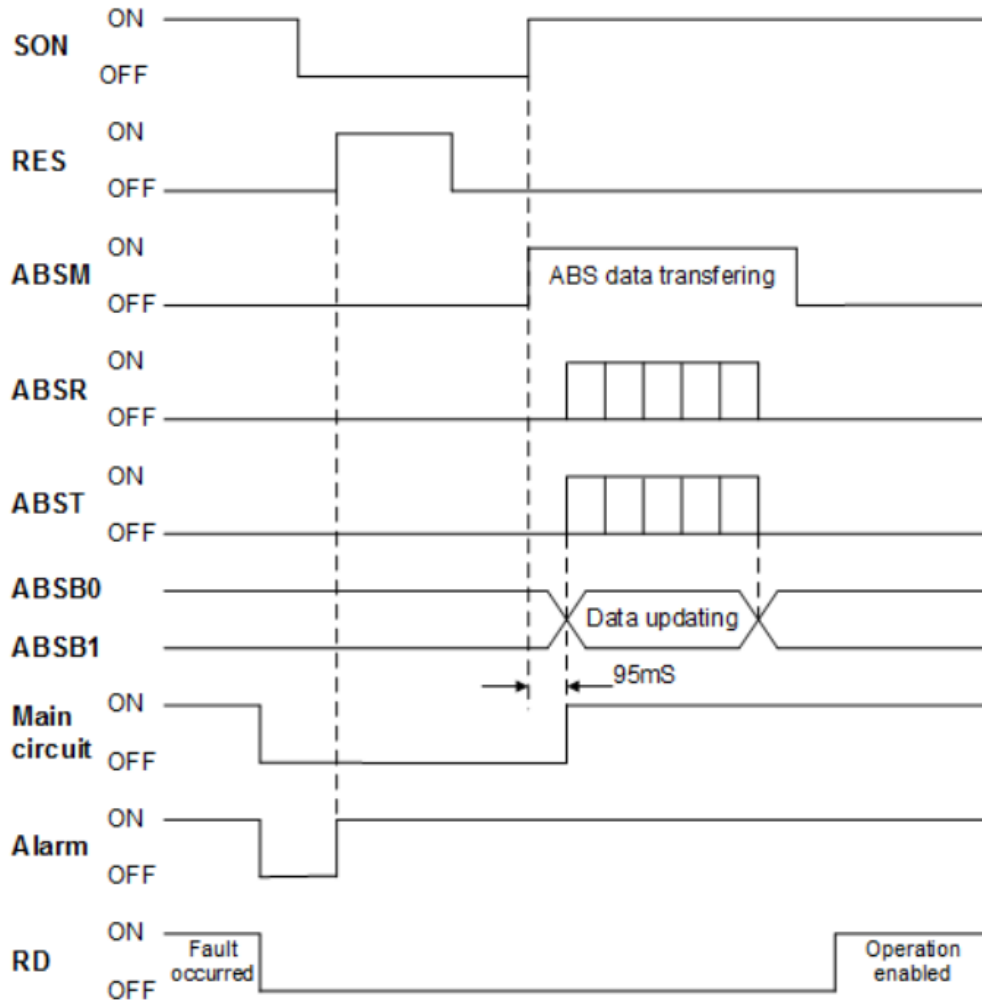

(4) Homing

Focus	Please perform the homing when the motor is static, otherwise the origin position may shift.
-------	--

Move to the target origin position by manual operation (JOG, test positioning). When turning on CR over 20mSec, the current position is regarded as the ABS origin and the data is stored in the non-volatile memory (the maximum number of writing is 1 million)

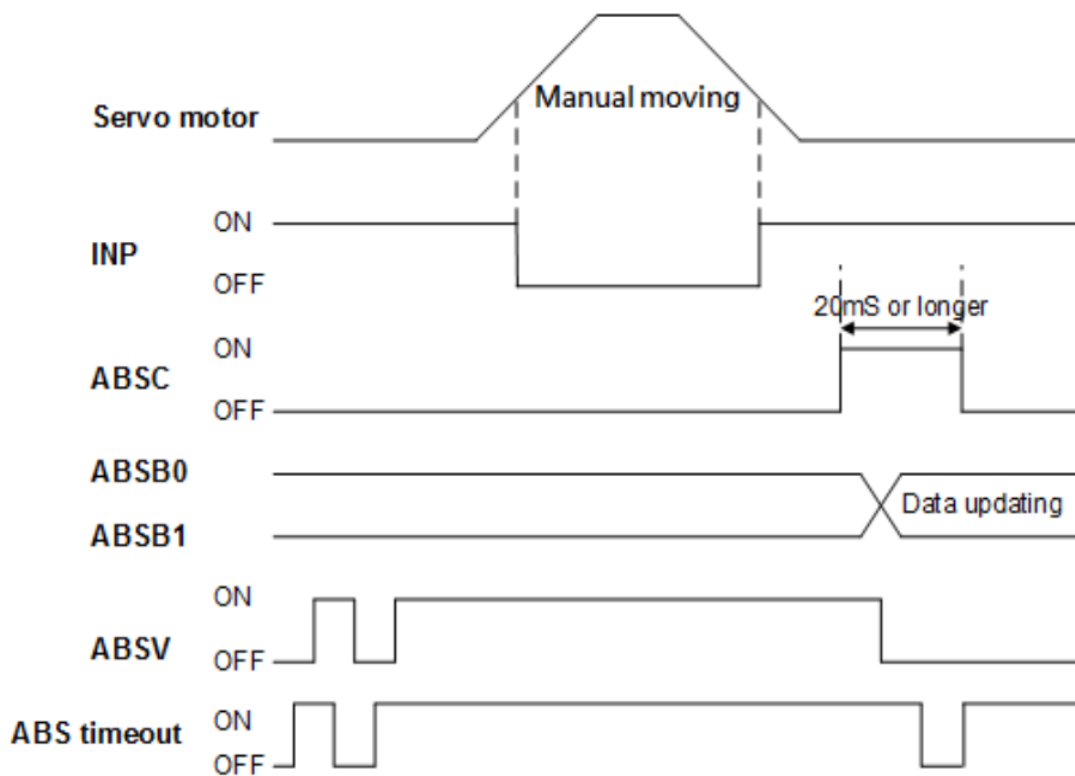

13.2 Delta absolute position detection system

This section mainly introduces the use of Delta PLC with SDC to access absolute position by DIO communication.

13.2.1 Signal description

When transmitting absolute position data, the signal of CN1 terminal will be changed.

Signal	Code	CN1 Pin	Function	I/O
ABS communication enable	ABSE	User-defined	When ABSE is on, the ABS mode is activated, it will enable ABSQ, ABSC, ABSR, ABSD.	DI-x
ABS signal request	ABSQ	17	Cross check pin during I/O transmission, ABSQ OFF means the host controller has issued the requested command; ABSQ ON means the host controller has processed the ABSD data.	DI-4 (Fixed)
ABS signal ready	ABSR	43	ABSR OFF means that ABSQ command can be received; ABSR ON means that the data is ready and the ABSD data has been updated.	DO-3 (Fixed)
ABS data content	ABSD	44	The output pin of ABS data, the data is guaranteed to be correct when ABSR is on.	DO-4 (Fixed)
ABS communication error	ABSW	User-defined	The related alarm of the absolute encoder is indicated by this DO output.	DO-x
Origin setting	ABSC	User-defined	When ABSC is turned on, the pulse number in the absolute encoder will be cleared to zero. This input is only valid when ABSE is turned on.	DI-x

Please refer to the following wiring example for details.

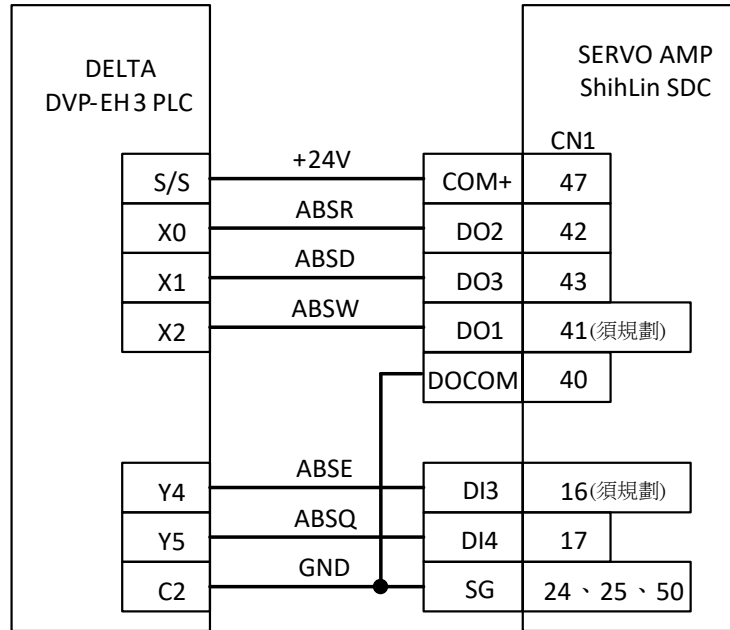

13.2.2 Start procedure

- (1) Install absolute motor and battery.
- (2) Parameter setting.

PA28 is set to "1" which is absolute system setting.

Set PA34 to "□□□0", then restart the drive to set the Delta absolute position detection system.

And then restart again to activate the parameter setting.

- (3) [AL.2A Absolute encoder error 1] Alarm release.

When the battery is replaced and the power is turned on for the first time, an "AL.2A Absolute Encoder error 1" alarm will occur. You can restart the power to release the alarm.

- (4) Absolute position loss [AL.2C Absolute encoder error 3] Alarm release

When the absolute system is powered on for the first time, an alarm of "AL.2C Absolute Encoder error 3" will occur. You can set PA29 to "1" or perform coordinate initialization to clear the alarm.

- (5) Homing.

Homing in the following conditions.

- (a) When setting absolute system.
- (b) When changing servo drive.
- (c) When changing servo motor.

(d) When absolute position loss [AL.2C Absolute encoder error 3] alarm occurs.

When setting an absolute position system, you can establish an absolute coordinate position by the origin setting. If you run the motor without establishing the origin, unexpected actions may occur.

13.2.3 Use DI/DO to initialize absolute coordinates

Absolute coordinate initialization can be performed with PA29 or DI/DO. If in Pr mode, please do the coordinate initialization by homing.

When DI ABSE is ON and DI ABSC is switched from OFF to ON, the coordinate initialization function will be executed. After execution, the pulse number of the absolute encoder will be cleared to zero. Please refer to the figure below for the operation sequence.

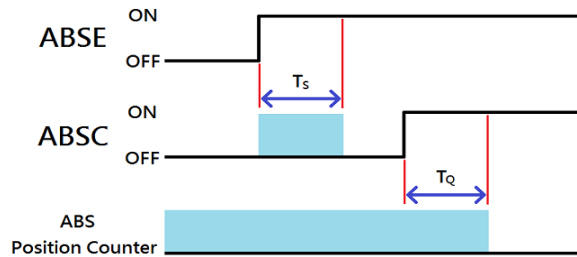

	Ts(ms)	Tq(ms)
Min	PD15 + 2	
Max	PD15 + 10	

Description of operation sequence.

1. When the host controller switches the ABSE signal from OFF to ON, it will need to wait for T_s before the system can proceed to the next step.
2. After reaching the T_s time, the host controller can perform the coordinate reset function, when the ABSC is switched from OFF to ON and after the T_q time, the pulse number of the absolute coordinate will be cleared to zero.

13.2.4 Use parameter settings to initialize absolute coordinates

You can write PA29 to perform absolute coordinate initialization by panel operation or communication command. When PA29 is set to 1, the absolute coordinates will be reset immediately. Please use the homing of Pr mode to initialize the coordinates in Pr mode.

Bit79 ~ Bit64	Bit63 ~ Bit32	Bit31 ~ Bit16	Bit15 ~ Bit0
Check Sum	Encoder pulse number per revolution 0 ~ 4194304 (22bit Encoder)	Encode revolution numbers -32768 ~ +32767	PA31 encoder status

Inspection and method description

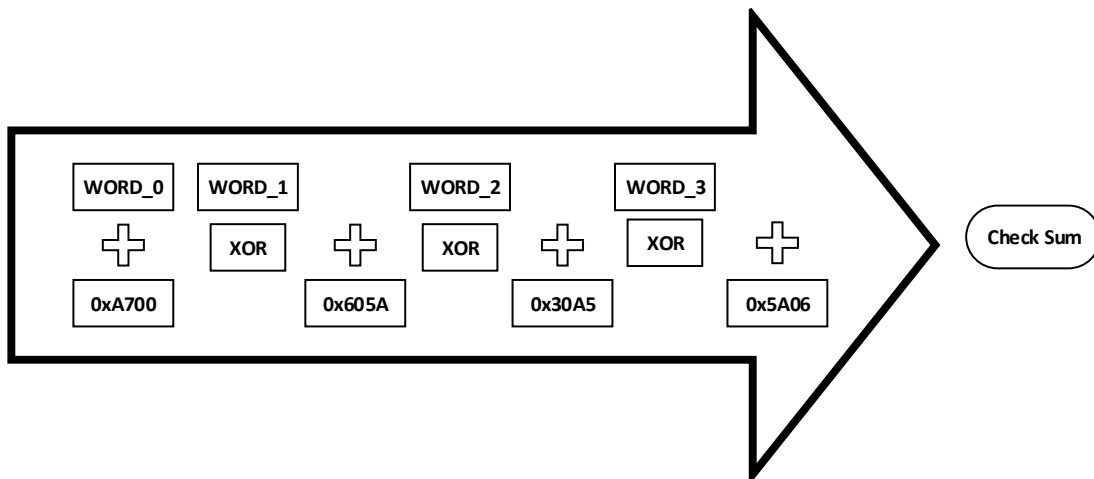

Check Sum = ((((((WORD_0+0xA700) xor WORD_1)+0x605A) xor WORD_2)+0x30A5) xor WORD_3)+0x5A06

Remind:

1. The algorithm has no sign.
2. 0xA700, 0x605A, 0x30A5, 0x5A06 are hexadecimal constants
3. WORD_0: encoder status(Bit15 ~ Bit0)
4. WORD_1: encoder revolution numbers(Bit31~Bit16)
5. WORD_2: encoder pulse number(Bit47 ~ Bit32)
6. WORD_3: encoder pulse number(Bit63 ~ Bit48)

13.2.5 Absolute position data transmission protocol

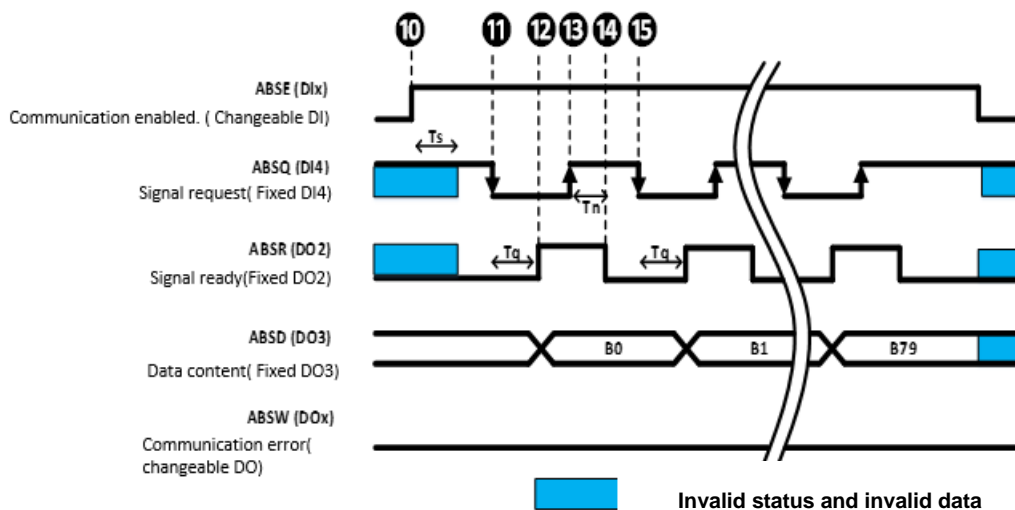
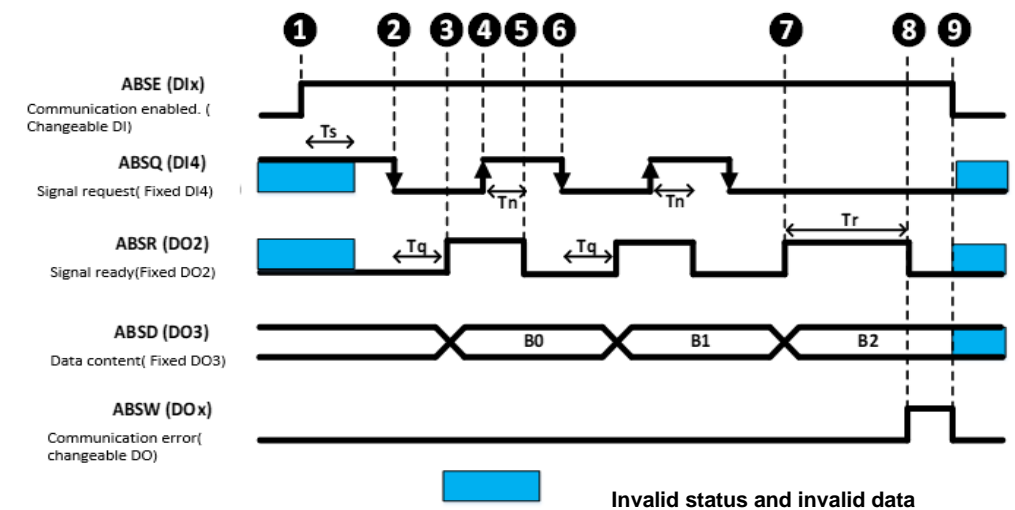

The description of communication procedure.

1. When starting communication, the host controller will enable ABSE signal and start DI/DO communication of absolute system. After T_s digital input filter time, DI4, DO2 and DO3 will switch to ABSQ, ABSR, ABSD.
2. The host controller sets the ABSQ signal to low level, which means that the host makes an access request to the driver.
3. After the T_q confirmation time, the driver has the data ready and enables the ABSR signal to notify the host controller for data accessing.
4. When the host controller detects that the ABSR is at the high level, it will immediately read the data signal on the ABSD. And then set the ABSQ to the high level to notify the driver for data accessing competition.
5. After the T_n confirmation time, the driver sets ABSR to the low level, and informs the host computer to prepare communication on the next bit.
6. When the host controller detects that the ABSR is at a low level, it will request the next bit from the driver.
7. If the driver has the data ready, the ABSR signal will be enabled.
8. After T_r communication waiting time, if the host controller does not read data and pulls up the ABSQ signal, ABSW alarm will occur and the communication will stop.
9. After the host controller detects the ABSW communication error, it will set ABSE to the low level to make it ready for re-communication.
10. Re-enable ABSE signal and re-communication.
11. The host controller sets the ABSQ signal to a low level and sends an accessing request.
12. After the T_q confirmation time, the driver will notify the host controller that data can be read.
13. When the host controller detects that the ABSR is at the high level, it will immediately read the data signal on the ABSD and set the ABSQ to the high level to notify the driver that the data has been read.
14. After the T_n confirmation time, the driver sets ABSR to the low level and informs the host controller that it can prepare for the communication of next bit.
15. When the host controller detects that the ABSR is at a low level, it will request the next bit from the driver. Repeat step 11 ~ step 14 to complete data communication of a total of 80 bits from 0 to 79.

13.3 Absolute battery specifications

Cautions for use

Carefully read the following safety cautions. Only use the specified batteries to avoid damage or dangerous conditions.



CAUTION

1. Make sure the installation location is free of vapor, corrosive and inflammable gas.
2. Correctly place the battery into the battery box to avoid short-circuit.
3. Do not short circuit the positive and negative electrodes of the battery, and do not install the battery in reverse direction



DANGER

1. Do not place the battery in a high-temperature environment over 100°C (212°F), as this may cause a fire or an explosion.
2. The batteries are non-rechargeable. Do not charge the batteries as this may result in an explosion.
3. Do not directly weld on the surface of the battery.

Battery specifications

Material	Lithium-thionyl chloride/inorganic electrolyte battery
Type	ER6C
Shihlin model name:	SDH-BAT
Standard voltage	3.6 V
Standard capacity	1800 mAh
Continuous discharge current	100 μ A
Dimension(D D x H)	14.5 x 51 mm
Weight	15 g
Operating temperature	-55°C ~ 85°C (-67°F ~ 185°F)

Battery life

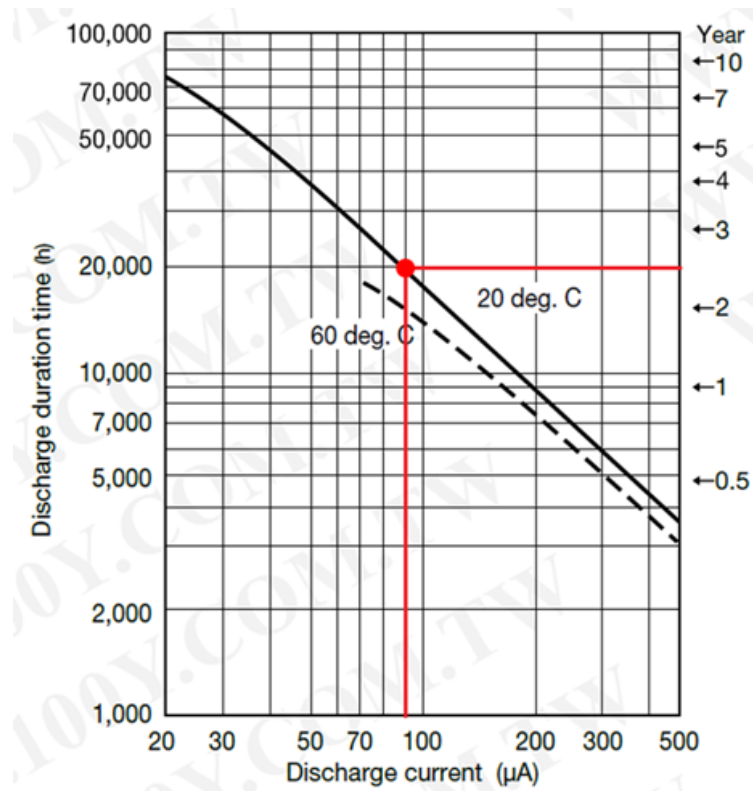

The figure above is the life curve provided by the battery manufacturer. If the absolute encoder current consumption is $90\mu\text{A}$, the battery life is about 20000hr, which is equivalent to 2.3 years.

14. Appendix

14.1 Accessories

Item	Name	Shihlin model name	Length(m m)
Encoder connector (CN2)	Low inertia (100W~1kW)encoder connector	SDH-ENCNL	--
Encoder cable	Low inertia (100W~1kW)encoder cable 2meters	SDH-ENL-2M-L/H	2000±100
	Low inertia (100W~1kW)encoder cable 5meters	SDH-ENL-5M-L/H	5000±100
	Low inertia (100W~1kW)encoder cable 10meters	SDH-ENL-10M-L/H	10000±100
Power connector	Low inertia (100W~1kW)power connector without brake	SDA-PWCNL1	--
	Low inertia (100W~1kW)power connector with brake	SDA-PWCNL2	--
Power cable	Low inertia (100W~1kW) power cable 1(without brake)	SDA-PWCNL1-2M-L/H	2000±100
	Low inertia (100W~1kW) power cable 2(without brake)	SDA-PWCNL1-5M-L/H	5000±100
	Low inertia (100W~1kW) power cable 3(without brake)	SDA-PWCNL1-10M-L/H	10000±100
	Low inertia (100W~1kW) power cable 1(with brake)	SDA-PWCNL2-2M-L/H	2000±100
	Low inertia (100W~1kW) power cable 2(with brake)	SDA-PWCNL2-5M-L/H	5000±100
	Low inertia (100W~1kW) power	SDA-PWCNL2-10M-L/H	10000±100

	cable 3(with brake)	H	0
Communication cable(CN4)	USB communication cable for drive and computer	SDA-USB3M	3000
Communication cable CN3/CN3L)	USB to RS-485 ADAPTER switching device	USB01	
	Data transmission cable 1. 5meters	SNKCBL1R5GTN2	1500
	Data transmission cable 3 meters	SNKCBL3GTN2	3000
	Data transmission cable 5 meters	SNKCBL5GTN2	5000
	Data transmission cable 10 meters	SNKCBL10GTN2	10000
I/O connector (CN1)	I/O connector	SDA-CN1	--
	I/O cable	SDA-TBL05M	500±10
	I/O cable	SDA-TB1M	1000±10
	I/O cable	SDA-TBL2M	2000±10
	I/O terminal block	SDA-TBL50	--
Battery set (CN5)	Absolute encoder battery set	SDH-BAT-SET	--
	Absolute encoder battery	SDH-BAT	--

❖ **Encoder connector**

❖ Part number: SDH-ENL (100W~1kW motor use)

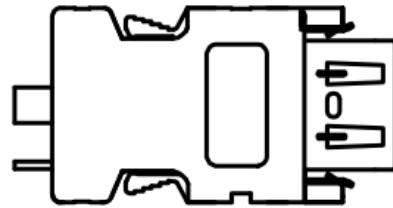
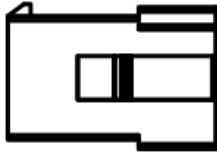

❖ **Encoder cable**

Low inertia encoder cable; use for 100W, 200W, 400W, 750W, 1kW.

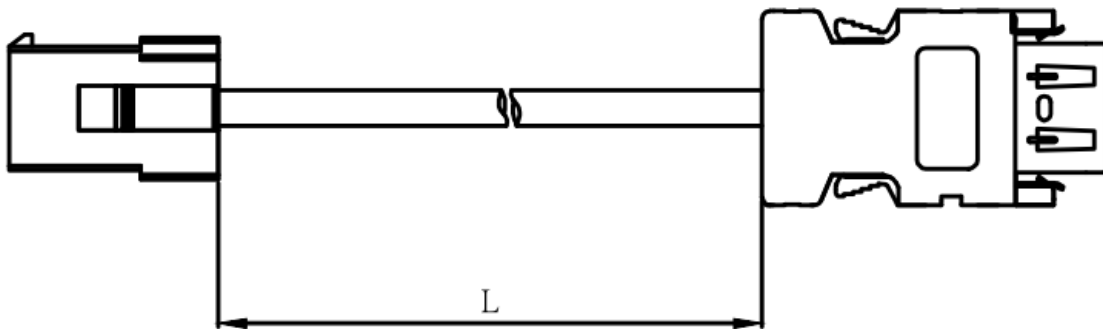

❖ **Power connector**

Part number: SDA-PWCNL1 (use for 100W~1kW Non-brake model)

SDA-PWCNL2 (use for 100W~1kW brake model)

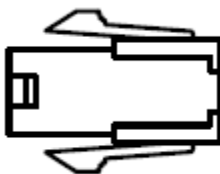

Low inertia power cable: use for 100W, 200W, 400W, 750W, 1kW.

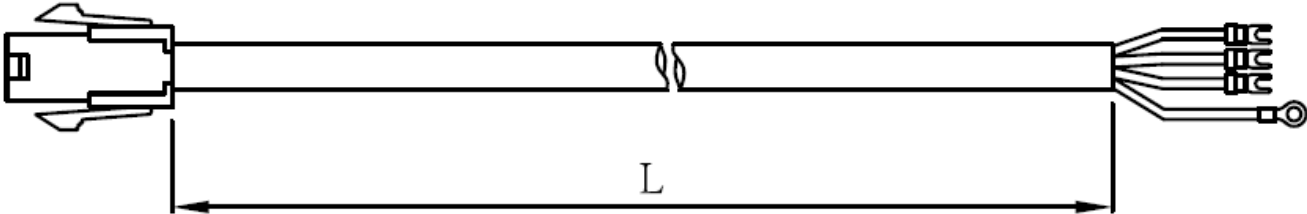

❖ **USB communication cable for drive and computer**

Part number: SDA-USB3M

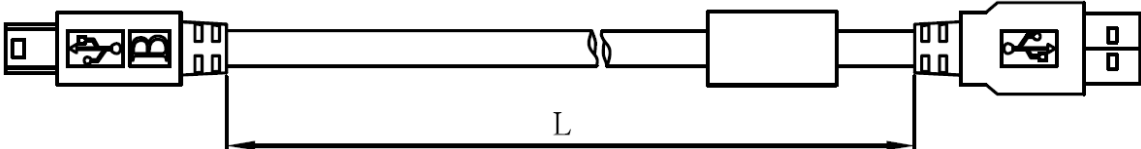

❖ **I/O connector**

Part number: SDA-CN1

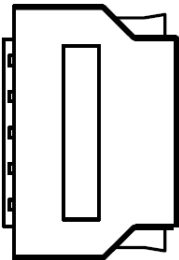

❖ **I/O cable**

Part number:SDA-TBL05M, SDA-TBL1M, SDA-TBL2M

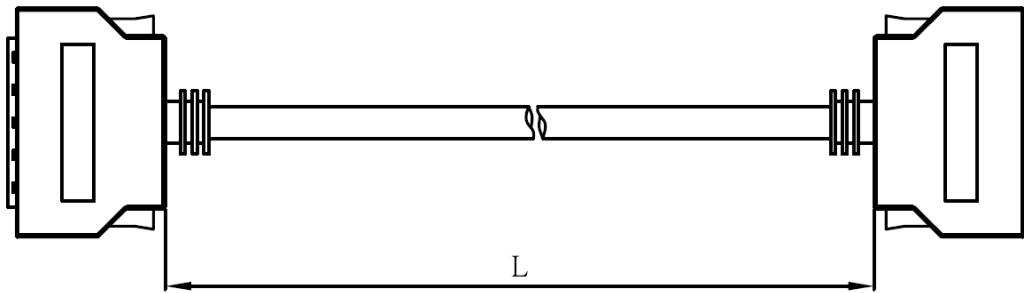

I/O terminal block

Part number: SDA-TBL50

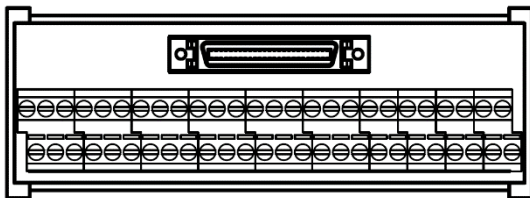

Absolute encoder accessory:

Absolute encoder battery set	Absolute encoder battery
Shihlin part number:SDH-BAT-SET	Shihlin part number:SDH-BAT

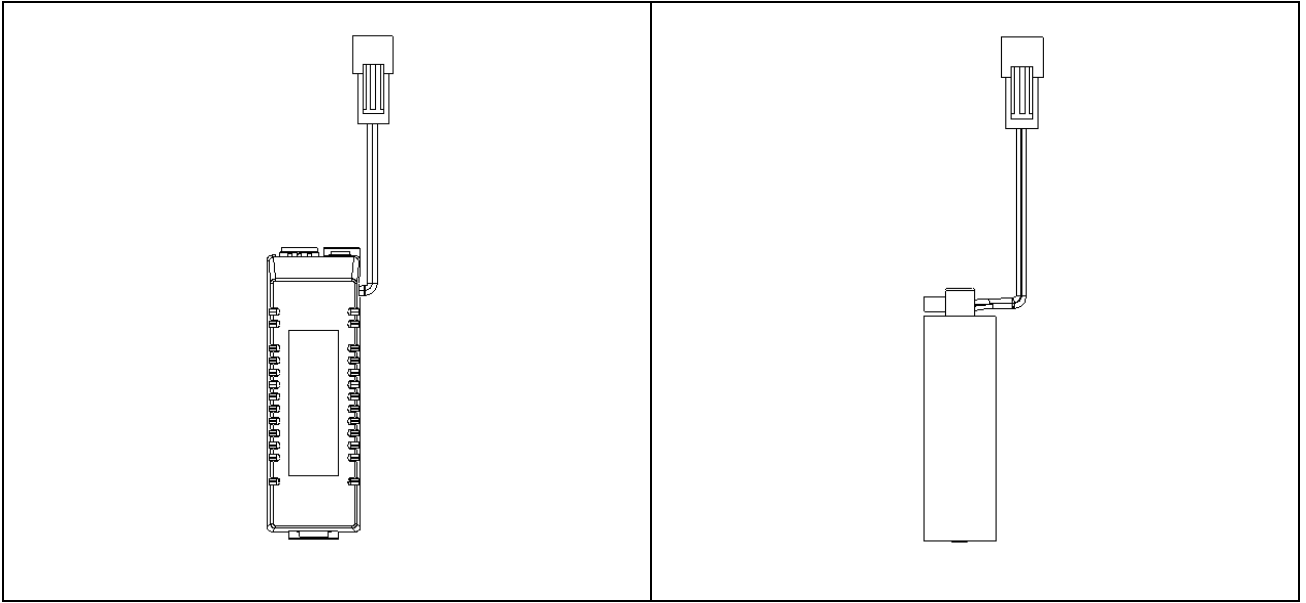

14.2 Regenerative resistor

Drive model name	Specification of built-in regenerative resistor			
	Resistance value (Ω)	Capacity (W)	PA10 Regenerative resistance value	PA11 Regenerative resistance capacity.
SDC-010A2□□	No built-in regenerative resistor			
SDC-020A2□□				
SDC-040A2□□	100	20	100	20
SDC-075A2□□	40	40	40	40
SDC-100A2□□	40	40	40	40

Drive model name	Specification of external resistor(proposed)		Specification of external resistor(proposed)		Resistor Part Number
	Min allowance resistance value (Ω)	Recommended capacity(W)	PA10 Regenerative resistance value	PA11 Regenerative resistance capacity	
SDC-010A2□□	100	300	100	300	ABR-300W100
SDC-020A2□□	100	300	100	300	ABR-300W100
SDC-040A2□□	100	300	100	300	ABR300W100
SDC-075A2□□	40	500	40	500	ABR-500W40
SDC-100A2□□	40	500	40	500	ABR-500W40

14.3 Table of communication address

NO	Communication address	NO	Communication address	NO	Communication address	NO	Communication address
PA01	0x0300	PA16	0x031E	PA31	0x033C	PA46	0x035A
PA02	0x0302	PA17	0x0320	PA32	0x033E	PA47	0x035C
PA03	0x0304	PA18	0x0322	PA33	0x0340	PA48	0x035E
PA04	0x0306	PA19	0x0324	PA34	0x0342	PA49	0x0360
PA05	0x0308	PA20	0x0326	PA35	0x0344	PA50	0x0362
PA06	0x030A	PA21	0x0328	PA36	0x0346		
PA07	0x030C	PA22	0x032A	PA37	0x0348		
PA08	0x030E	PA23	0x032C	PA38	0x034A		
PA09	0x0310	PA24	0x032E	PA39	0x034C		
PA10	0x0312	PA25	0x0330	PA40	0x034E		
PA11	0x0314	PA26	0x0332	PA41	0x0350		
PA12	0x0316	PA27	0x0334	PA42	0x0352		
PA13	0x0318	PA28	0x0336	PA43	0x0354		
PA14	0x031A	PA29	0x0338	PA44	0x0356		
PA15	0x031C	PA30	0x033A	PA45	0x0358		

NO	Communi cation address	NO	Communi cation address	NO	Communi cation address	NO	Communi cation address
PB01	0x0400	PB16	0x041E	PB31	0x043C	PB46	0x045A
PB02	0x0402	PB17	0x0420	PB32	0x043E	PB47	0x045C
PB03	0x0404	PB18	0x0422	PB33	0x0440	PB48	0x045E
PB04	0x0406	PB19	0x0424	PB34	0x0442	PB49	0x0460
PB05	0x0408	PB20	0x0426	PB35	0x0444	PB50	0x0462
PB06	0x040A	PB21	0x0428	PB36	0x0446	PB51	0x0464
PB07	0x040C	PB22	0x042A	PB37	0x0448	PB52	0x0466
PB08	0x040E	PB23	0x042C	PB38	0x044A	PB53	0x0468
PB09	0x0410	PB24	0x042E	PB39	0x044C	PB54	0x046A
PB10	0x0412	PB25	0x0430	PB40	0x044E	PB55	0x046C
PB11	0x0414	PB26	0x0432	PB41	0x0450	PB56	0x046E
PB12	0x0416	PB27	0x0434	PB42	0x0452	PB57	0x0470
PB13	0x0418	PB28	0x0436	PB43	0x0454	PB58	0x0472
PB14	0x041A	PB29	0x0438	PB44	0x0456	PB59	0x0474
PB15	0x041C	PB30	0x043A	PB45	0x0458		

NO	Communi cation address	NO	Communi cation address	NO	Communi cation address	NO	Communi cation address
PC01	0x0500	PC21	0x0528	PC41	0x0550	PC61	0x0578
PC02	0x0502	PC22	0x052A	PC42	0x0552	PC62	0x057A
PC03	0x0504	PC23	0x052C	PC43	0x0554	PC63	0x057C
PC04	0x0506	PC24	0x052E	PC44	0x0556	PC64	0x057E
PC05	0x0508	PC25	0x0530	PC45	0x0558	PC65	0x0580
PC06	0x050A	PC26	0x0532	PC46	0x055A	PC66	0x0582
PC07	0x050C	PC27	0x0534	PC47	0x055C	PC67	0x0584
PC08	0x050E	PC28	0x0536	PC48	0x055E	PC68	0x0586
PC09	0x0510	PC29	0x0538	PC49	0x0560	PC69	0x0588
PC10	0x0512	PC30	0x053A	PC50	0x0562	PC70	0x058A

NO	Communicati on address	NO	Communicati on address	NO	Communicati on address
PE01	0x0700	PE34	0x0742	PE67	0x0784
PE02	0x0702	PE35	0x0744	PE68	0x0786
PE03	0x0704	PE36	0x0746	PE69	0x0788
PE04	0x0706	PE37	0x0748	PE70	0x078A
PE05	0x0708	PE38	0x074A	PE71	0x078C
PE06	0x070A	PE39	0x074C	PE72	0x078E
PE07	0x070C	PE40	0x074E	PE73	0x0790
PE08	0x070E	PE41	0x0750	PE74	0x0792
PE09	0x0710	PE42	0x0752	PE75	0x0794
PE10	0x0712	PE43	0x0754	PE76	0x0796
PE11	0x0714	PE44	0x0756	PE77	0x0798
PE12	0x0716	PE45	0x0758	PE78	0x079A
PE13	0x0718	PE46	0x075A	PE79	0x079C
PE14	0x071A	PE47	0x075C	PE80	0x079E
PE15	0x071C	PE48	0x075E	PE81	0x07A0
PE16	0x071E	PE49	0x0760	PE82	0x07A2
PE17	0x0720	PE50	0x0762	PE83	0x07A4
PE18	0x0722	PE51	0x0764	PE84	0x07A6
PE19	0x0724	PE52	0x0766	PE85	0x07A8
PE20	0x0726	PE53	0x0768	PE86	0x07AA
PE21	0x0728	PE54	0x076A	PE87	0x07AC
PE22	0x072A	PE55	0x076C	PE88	0x07AE
PE23	0x072C	PE56	0x076E	PE89	0x07B0
PE24	0x072E	PE57	0x0770	PE90	0x07B2
PE25	0x0730	PE58	0x0772	PE91	0x07B4
PE26	0x0732	PE59	0x0774	PE92	0x07B6
PE27	0x0734	PE60	0x0776	PE93	0x07B8
PE28	0x0736	PE61	0x0778	PE94	0x07BA
PE29	0x0738	PE62	0x077A	PE95	0x07BC
PE30	0x073A	PE63	0x077C	PE96	0x07BE
PE31	0x073C	PE64	0x077E	PE97	0x07C0
PE32	0x073E	PE65	0x0780	PE98	0x07C2
PE33	0x0740	PE66	0x0782	PE99	0x07C4

NO	Communicati on address	NO	Communicati on address	NO	Communicati on address
PF01	0x0800	PF34	0x0842	PF67	0x0884
PF02	0x0802	PF35	0x0844	PF68	0x0886
PF03	0x0804	PF36	0x0846	PF69	0x0888
PF04	0x0806	PF37	0x0848	PF70	0x088A
PF05	0x0808	PF38	0x084A	PF71	0x088C
PF06	0x080A	PF39	0x084C	PF72	0x088E
PF07	0x080C	PF40	0x084E	PF73	0x0890
PF08	0x080E	PF41	0x0850	PF74	0x0892
PF09	0x0810	PF42	0x0852	PF75	0x0894
PF10	0x0812	PF43	0x0854	PF76	0x0896
PF11	0x0814	PF44	0x0856	PF77	0x0898
PF12	0x0816	PF45	0x0858	PF78	0x089A
PF13	0x0818	PF46	0x085A	PF79	0x089C
PF14	0x081A	PF47	0x085C	PF80	0x089E
PF15	0x081C	PF48	0x085E	PF81	0x08A0
PF16	0x081E	PF49	0x0860	PF82	0x08A2
PF17	0x0820	PF50	0x0862	PF83	0x08A4
PF18	0x0822	PF51	0x0864	PF84	0x08A6
PF19	0x0824	PF52	0x0866	PF85	0x08A8
PF20	0x0826	PF53	0x0868	PF86	0x08AA
PF21	0x0828	PF54	0x086A	PF87	0x08AC
PF22	0x082A	PF55	0x086C	PF88	0x08AE
PF23	0x082C	PF56	0x086E	PF89	0x08B0
PF24	0x082E	PF57	0x0870	PF90	0x08B2
PF25	0x0830	PF58	0x0872	PF91	0x08B4
PF26	0x0832	PF59	0x0874	PF92	0x08B6
PF27	0x0834	PF60	0x0876	PF93	0x08B8
PF28	0x0836	PF61	0x0878	PF94	0x08BA
PF29	0x0838	PF62	0x087A	PF95	0x08BC
PF30	0x083A	PF63	0x087C	PF96	0x08BE
PF31	0x083C	PF64	0x087E	PF97	0x08C0
PF32	0x083E	PF65	0x0880	PF98	0x08C2
PF33	0x0840	PF66	0x0882	PF99	0x08C4

14.4 Compliance with global standards

14.4.1. Safety instructions

Before installing this equipment, please read this manual carefully to ensure use it correctly. This section explains the safety regulations for users and equipment operation.



DANGER

! Because there is a possibility of electric shock, you should turn off the power for more than 20 minutes, after the charging indicator is off and the voltage test is confirmed, It can be wired or inspected, otherwise it may cause electric shock.

14.4.2. Professional technicians

Arrange a professional technician who has received professional training to install the SDC servo drive.

14.4.3. Compliance with standards

(1) Safety regulations

SDC servo drive complies with IEC/EN61800-5-1 standards

(2) Compliance with EU standards

SDC servo complies with EMC directive(2014/30/EU) and low voltage directive(2014/35/EU)

(3) Compliance with USA/Canada regulations

This servo drive design complies with UL 61800-5-1 及 CSA C22.2 No. 274-17

(a) Installation

The minimum size of the distribution box is 200% of the size of the SDC servo drive. For ventilation of the fan and to keep the ambient temperature below 55°C, only copper wires can be used for wiring. The servo drive should be installed in a metal distribution box.

(b) Overload protection feature

The SDC servo drive has overload protection function. (It is specified based on 120% of the rated current of the servo driver (full load current).)

(c) Motor overheat protection

There is no temperature sensor inside the motor, and the SDC series don't have overheat protection.

(d) Capacitor discharge

After the power is turned off, do not touch the servo and its terminals immediately. The capacitor discharge takes 20 minutes.

(e) About wiring protection

When installing equipment in the United States, branch circuit protection is based on national electrical regulations and local regulations. When installing equipment in Canada, branch circuit protection is based on the Canadian Electrical regulations and provincial regulations.

14.4.4. Correct use method

The equipment used must comply with the specifications (voltage, temperature, etc. , please refer to section 11.1 for details).

(1) Power cable

Refer to section 3. 1. 6 for detailed power cable selection table.

Note 1: When connecting to the terminal block, use the screws provided with the terminal block.

Note 2: The letters in the table indicate crimping tools, please refer to the recommended crimping terminal table for crimping terminals and suitable tools.

Note 3: The cable AWG selection depends on the specifications of the connected servo motor.

(2) Torque of fixed terminal block: Crimp terminals must comply with UL specifications, and insulating sleeves must be used to prevent direct contact.

Drive	Recommended torque(Nt-m)			
	L1, L2	U, V, W	P, C, N	PE
SDC-010A2□	0.8	0.8	0.8	1.4
SDC-020A2□				
SDC-040A2□				
SDC-075A2□				
SDC-100A2□				

(3) Example of non-fuse circuit breaker selection

Drive	UL certified current-limiting circuit breaker	Example
SDC-010A2	240 V, 5 A	NF50-SVFU 5A
SDC-020A2		
SDC-040A2	240 V, 10 A	NF50-SVFU 3P 10A
SDC-075A2	240 V, 15 A	NF50-SVFU 3P 15A
SDC-100A2		

In order to meet the requirements of the North American safety standard UL61800-5-1, be sure to connect a circuit breaker on the input side to prevent accidents caused by short circuits in the internal circuit. Install adequate branch circuit short circuit protection in accordance with applicable regulations and this manual. This product is suitable for circuits with a rated fusing capacity below 5000A and a maximum voltage of 240Vac.

14.4.5. Basic inspection and maintenance

14.4.5.1. Basic inspection

It is recommended that the user do the following various tests regularly. During the test, please carefully check whether the servo drive is powered off and the charging indicator is off, and then perform the following tests:

- ◆ Check whether the screws of the terminal block, driver installation part, servo motor and mechanism connection are loose, if yes, please tighten it.
- ◆ The servo should not be placed where harmful gas exists.
- ◆ Avoid placing conductive objects next to the drive and the drive wiring.
- ◆ Servo motor wiring should avoid excessively long bare area and do not use damaged or broken wire.
- ◆ Insulation should be done at the wiring terminal.
- ◆ Check whether the external AC220V voltage is correct.
- ◆ Check whether the operation switch is OFF.
- ◆ Check whether power wiring and Encoder wiring is correct.

14.4.5.2. Maintenance

Do not disassemble the servo drive by yourself to perform maintenance. Please follow below instruction for regular maintenance:

- ◆ Wipe the servo drive and servo motor regularly to avoid the adhesion of dust.
- ◆ Do not operate for a long time in harsh environments.
- ◆ The vents of the servo drive should be kept clean to avoid dust accumulation.

14.4.5.3. Parts service time

The lifetime of the parts may be changed due to the user's operating environment. When an abnormality is found, it needs to be replaced immediately. Please contact the Shihlin distributor for replacing parts. The service life of the parts is as follows:

Component name	Approximate lifetime	Description
Relay	100,000times	The power capacity will impact its life, the accumulative number of switching is about 100,000 times.
Cooling fan	10,000-30,000 hours(2-3 years)	Continuous operation or placing the servo drive in a place with harmful gas will shorten the service life of the fan, which is about 2 to 3 years. However, if the fan runs with abnormal noise, it needs to be replaced.
Rectified capacitor	10years	If the rectified capacitor is affected by the ripple current, its characteristics will be deteriorated. The service life of the capacitor is affected by the surrounding temperature and use conditions. If the servo is operated in a general environment with air conditioning, the service life is about 10 years.

14.5 Manual version and revision history

Manual version: V1.01

Release month: May. 2021

Release date	Manual version	Revision contents
2021/5/20	V1.00	Initial release
2021/5/16	V1.01	1. Modify PA23 parameter content 2. Support 22bit optical encoder motor (L005~L100)