

AUTOMATION FOR  
SMART MANUFACTURING

# SHIHLIN INVERTER SC3/SE3/SA3/SF3/SS2



OHSAS 18001 ISO 14001 ISO 9001  





## About Shihlin Electric

Shihlin Electric Corp., established in 1955, devoted to research and develop power related products, which cover from Automobile Equipment System, Breaker Switchgear & System, Heavy Electric System, and Factory Automation. Our persistent in the belief of "improvement over time" in running the operation and in corporate development has not only made us a leader in the domestic market, but also performed splendidly in the overseas market. To make our brand awareness highly recognized, we cautious deployment and work hard on overseas marketing and sales.

The setup of overseas branches and factories had compliance with the rapid growth of product demand and to cater to the service of customer worldwide. Shihlin Electric, even with over 60 years of experiences, is still improving itself to better keep up with the globalization. Now, we spare no effort in searching for suitable business partner and expand our brand into local market. We provide not just the qualified product but also excellent service and professional knowledge.

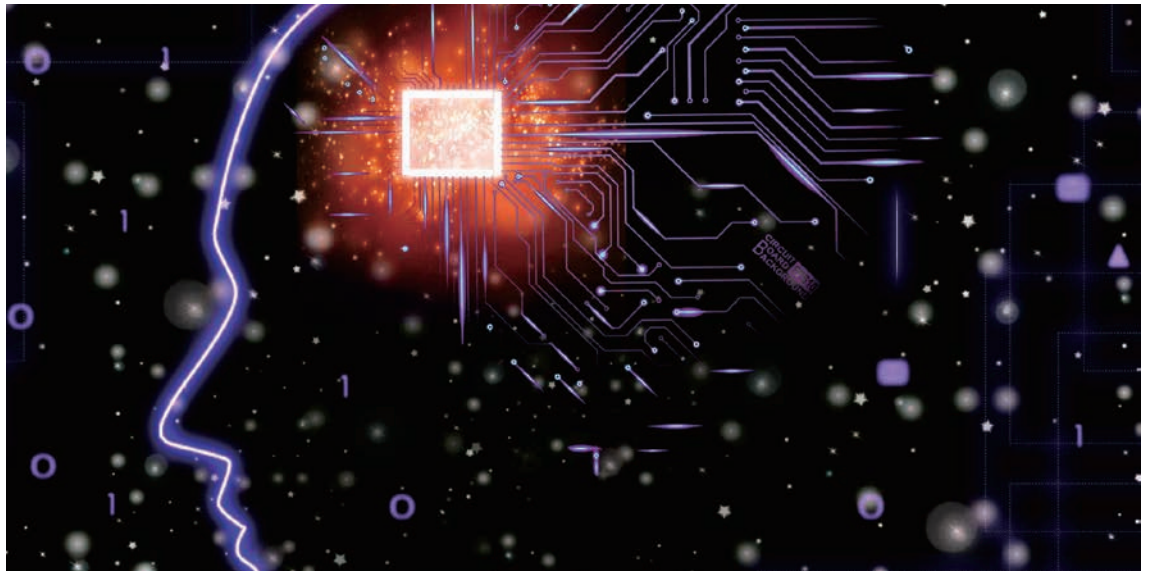
Now, with to the advance of science and technology, the market demand for electrical product would only grow exponentially. We hold great vision for the coming future. As we are in search of excellence, we do will take part in global competition.



## Core Business Units

- \*Transmission & Distribution Electrical Products
- \*Power Control, Switches & Breakers
- \*Factory Automation Products
- \*Automotive Electrical Component Products

# Table of Contents

**SC3 series** 01  
Compact Inverter with Vector Control

**SE3 series** 09  
High Speed Closed Loop/Communication Inverter

**SA3 series** 19  
Advanced Closed Loop Communication Inverter

**SF3 series** 31  
Communication Vector Control Inverter

**SS2 series** 41  
General low kW Vector Control Inverter

**Optional Equipment** 49  
Accessories and Optional Equipment

# SC3 series

Compact Inverter with  
Vector Control

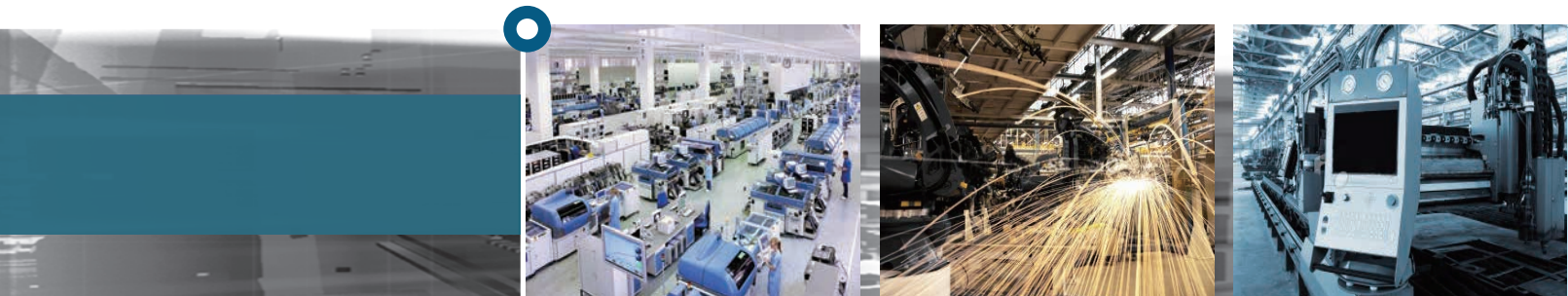

## Product Range

| Model |     | kW<br>(HP)   | 0.2<br>(0.25) | 0.4<br>(0.5) | 0.75<br>(1) | 1.5<br>(2) | 2.2<br>(3) | 3.7<br>(5) | 5.5<br>(7.5) |
|-------|-----|--------------|---------------|--------------|-------------|------------|------------|------------|--------------|
| SC3   | 021 | 1 phase 220V |               |              |             |            |            |            |              |
|       | 023 | 3 phase 220V |               |              |             |            |            |            |              |
|       | 043 | 3 phase 440V |               |              |             |            |            |            |              |

## Main Features

- \* High performance vector control
- \* Built-in operation wheel
- \* Full PCB coating and isolated air duct
- \* Dual RS485 communication interface
- \* Built-in PID controller
- \* Built-in RFI filter
- \* Built-in Modbus communication(up to 115200bps)
- \* Drive PM motor(Customized model)
- \* Built-in proportion linkage function
- \* Built-in 8 sets of programmed operation function
- \* Built-in 5 point V/F curve
- \* Built-in multi-function monitoring
- \* Built-in energy saving algorithm
- \* Built-in low current/overtorque detection
- \* Cooling fan auto on/off in different temperature
- \* 12 sets of alarm record, with detailed information of the latest 2 alarm (with frequency / current / voltage / temperature rising rate /DC bus voltage /operation time record)
- \* Din rail installation
- \* External keypad
- \* Output frequency up to 599Hz
- \* Output short circuit function

## Model Identification

| Series     | Voltage level   | Capacity | Version  |
|------------|---|----------|--|
| SC3 series | 043 : three phase 440V<br>023 : three phase 220V<br>021 : single phase 220V | 0.75kW   | None : General model<br>-xy : Customized or specialized or region difference |

SC3

### Product Features

#### Built-in RFI filter

- A screw switch to turn on/off RFI filter, reduce electromagnetic interference.

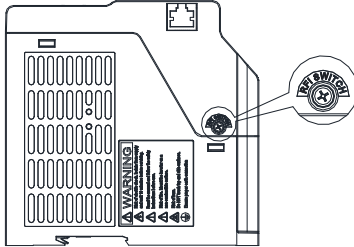

Note: Please refer to manual for installation details.

#### Coating & Isolated Air Duct

- All PCB is coated with insulation material.
- Heat sink is separated and isolated from the PCB, prevent dust/oil from contacting electronic components.

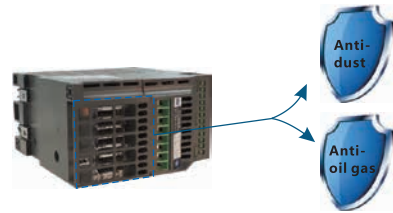

Note: Please do not install the inverter in a heavily polluted environment without any protection.

#### Dual RS485 interface

- Screw terminal for easy connection with multiple machines.
- RJ45 for easy connection with external keypad.



Note: External keypad and RS485 cannot work at the same time.

#### Easy Maintenance

- Fan is removable.
- The position of the fan is on the top, very easy to replace.



#### Optimized Operation Wheel Design

- The position of the operation wheel is lower than the front cover, avoiding all external force from damaging the wheel.



#### Grouping Parameters - Easy Setup

| Group | Parameter Number | Name                         | Setting Range                                |
|-------|------------------|------------------------------|--|
| 01-00 | P.1              | Maximum frequency            | 0.00 ~ 01-02 (P.18) Hz                       |
| 01-01 | P.2              | Minimum frequency            | 0 ~ 120.00Hz                                 |
| 01-02 | P.18             | High-speed maximum frequency | 01-00 (P.1) ~ 599.00Hz                       |
| 01-03 | P.3              | Base frequency               | 50Hz system setting: 0 ~ 599.00Hz            |
|       |                  |                              | 60Hz system setting: 0 ~ 599.00Hz            |
| 01-04 | P.19             | Base voltage                 | 0 ~ 1000.0V                                  |
|       |                  |                              | 99999: Change according to the input voltage |

SC3 series: Similar functions are grouped into same sectors instead of sequence numbers.



SC3

## Electrical Specifications

### 220V Series single-phase

| Frame                   |   | A  |      |      | B   |     |
|-------------------------|---|--|------|------|-----|-----|
| Model SC3-021- □□□ K-xy |   | 0.2  | 0.4  | 0.75 | 1.5 | 2.2 |
| Output                  | Rated output capacity (kVA)             | 0.6  | 1    | 1.5  | 2.5 | 4.2 |
|                         | Rated output current (A)                | 1.8  | 2.7  | 4.5  | 8   | 11  |
|                         | Applicable motor capacity (HP)          | 0.25   | 0.5  | 1    | 2   | 3   |
|                         | Applicable motor capacity (kW)          | 0.2  | 0.4  | 0.75 | 1.5 | 2.2 |
|                         | Overload current rating                 | 150% 60 seconds 200% 1 second (inverse time characteristics) |      |      |     |     |
|                         | Carrier frequency (kHz)                 | 1~15kHz  |      |      |     |     |
|                         | Maximum output voltage                  | Three-phase 200-240V   |      |      |     |     |
| Power supply            | Rated power voltage                     | Single-phase 200-240V 50Hz / 60Hz                            |      |      |     |     |
|                         | Power voltage permissible fluctuation   | Single-phase 170-264V 50Hz / 60Hz                            |      |      |     |     |
|                         | Power frequency permissible fluctuation | ±5%  |      |      |     |     |
|                         | Power source capacity (kVA)             | 0.75   | 1.5  | 2.5  | 3.5 | 6.4 |
| Cooling method          | Self cooling                            | Forced air cooling   |      |      |     |     |
| Weight (kg)             | 0.66                                    | 0.6  | 0.73 | 1.38 | 1.4 |     |

### 220V Series three-phase

| Frame                    |   | A  |      |      |      | B   |      |
|--------------------------|---|--|------|------|------|-----|------|
| Model SC3-023 - □□□ K-xy |   | 0.2  | 0.4  | 0.75 | 1.5  | 2.2 | 3.7  |
| Output                   | Rated output capacity (kVA)             | 0.6  | 1.2  | 2    | 3.2  | 4.2 | 6.7  |
|                          | Rated output current (A)                | 1.8  | 3    | 5    | 8    | 11  | 17.5 |
|                          | Applicable motor capacity (HP)          | 0.25   | 0.5  | 1    | 2    | 3   | 5    |
|                          | Applicable motor capacity (kW)          | 0.2  | 0.4  | 0.75 | 1.5  | 2.2 | 3.7  |
|                          | Overload current rating                 | 150% 60 seconds 200% 1 second (inverse time characteristics) |      |      |      |     |      |
|                          | Carrier frequency (kHz)                 | 1~15kHz  |      |      |      |     |      |
|                          | Maximum output voltage                  | Three-phase 200-240V   |      |      |      |     |      |
| Power supply             | Rated power voltage                     | Three-phase 200-240V 50Hz / 60Hz                             |      |      |      |     |      |
|                          | Power voltage permissible fluctuation   | Three-phase 170-264V 50Hz / 60Hz                             |      |      |      |     |      |
|                          | Power frequency permissible fluctuation | ±5%  |      |      |      |     |      |
|                          | Power source capacity (kVA)             | 0.75   | 1.5  | 2.5  | 4.5  | 6.4 | 10   |
| Cooling method           | Self cooling                            | Forced air cooling   |      |      |      |     |      |
| Weight (kg)              | 0.69                                    | 0.69   | 0.70 | 0.73 | 1.32 | 1.4 |      |

## Electrical Specifications

### 440V Series three-phase

| Frame                   |   | A  |                    |      | B    |      |      |
|-------------------------|---|--|--------------------|------|------|------|------|
| Model SC3-043- □□□ K-xy |   | 0.4  | 0.75               | 1.5  | 2.2  | 3.7  | 5.5  |
| Output                  | Rated output capacity (kVA)             | 1  | 2                  | 3    | 4.6  | 6.9  | 9.2  |
|                         | Rated output current (A)                | 1.5  | 2.6                | 4.2  | 6    | 9    | 12   |
|                         | Applicable motor capacity (HP)          | 0.5  | 1                  | 2    | 3    | 5    | 7.5  |
|                         | Applicable motor capacity (kW)          | 0.4  | 0.75               | 1.5  | 2.2  | 3.7  | 5.5  |
|                         | Overload current rating                 | 150% 60 seconds 200% 1 second (inverse time characteristics) |                    |      |      |      |      |
|                         | Carrier frequency (kHz)                 | 1~15kHz  |                    |      |      |      |      |
|                         | Maximum output voltage                  | Three-phase 380-480V   |                    |      |      |      |      |
| Power supply            | Rated power voltage                     | Three-phase 380-480V 50Hz / 60Hz                             |                    |      |      |      |      |
|                         | Power voltage permissible fluctuation   | Three-phase 323-528V 50Hz / 60Hz                             |                    |      |      |      |      |
|                         | Power frequency permissible fluctuation | ±5%  |                    |      |      |      |      |
|                         | Power source capacity (kVA)             | 1.5  | 2.5                | 4.5  | 6.9  | 10.4 | 11.5 |
|                         | Cooling method                          | Self cooling   | Forced air cooling |      |      |      |      |
| Weight (kg)             | 0.74                                    | 0.74   | 0.81               | 1.37 | 1.37 | 1.42 |      |



SC3

## Common Specifications

|   |                                   |  |
|---|-----------------------------------|--|
| Control method                                    |                                   | SVPWM, V/F control, General flux vector control  |
| Output frequency range                            |                                   | 0~599.00Hz   |
| Frequency setting resolution                      | Digital setting                   | Within 100Hz, the resolution is 0.01Hz<br>Above 100Hz, the resolution is 0.1Hz.  |
|   | Analog setting                    | DC 0~5V or 4~20mA signal: 11 bit,<br>DC 0~10V signal: 12 bit.  |
| Output frequency accuracy                         | Digital setting                   | Maximum target frequency±0.01%.  |
|   | Analog setting                    | Maximum target frequency±0.1%.   |
| Starting torque                                   |                                   | Under General flux vector control: 180% / 3Hz, 200% / 5Hz  |
| V/F characteristics                               |                                   | Constant torque curve, variable torque curve, five-point VF curve  |
| Acceleration / deceleration curve characteristics |                                   | Linear acceleration / deceleration curve, S shape acceleration /deceleration curve 1 & 2 & 3   |
| Drive motor                                       |                                   | Induction motor (IM)   |
| Stalling protection                               |                                   | The stalling protection level can be set from 0~250%. Default value 150%   |
| Target frequency setting                          |                                   | Built-in keypad setting, DC 0~5V/10V signal, DC 4~20 mA signal, multi-speed stage level setting, communication setting.  |
| Built-in keypad                                   | Operation monitoring              | Output frequency, output current, output voltage, PN voltage, electronic thermal accumulation rate, temperature rising accumulation rate, output power, analog input signal value, digital input and output terminal status...; alarm history 12 sets with operation details of the latest two set.  |
|   | LED indicator(6)                  | Frequency monitoring indicator, voltage monitoring indicator, current monitoring indicator, motor running indicator, mode switch indicator, PU mode indicator.   |
| Communication function                            |                                   | RS485 communication, choose between Shihlin / Modbus communication protocol, baud rate up to 115200bps.  |
| Protection mechanism / alarm function             |                                   | Output short circuit protection, over-current protection, over-voltage protection, under-voltage protection, motor over-heat protection (06-00(P.9)), IGBT module over-heat protection, communication error protection, PID error protection, memory error protection, CPU error protection, stall prevention, module over-heat protection, input power fail protection, terminal 3-5 disconnect protection, over torque protection, current leakage to ground protection, hardware detect circuit error protection. |
| Environment                                       | Ambient temperature               | -10 ~ +50°C(non-freezing), side by side installation-10~ +40°C(non-freezing).  |
|   | Ambient humidity                  | Below 90%Rh (non-condensing).  |
|   | Storage temperature               | -20 ~ +65°C  |
|   | Surrounding environment           | Indoor, no corrosive gas, no flammable gas, no flammable powder.   |
|   | Altitude                          | Altitude below 2000 m, when altitude is above 1000 m, derate the rated current 2% per 100 m  |
|   | Vibration                         | Vibration below 5.9m/s <sup>2</sup> (0.6G)   |
|   | Grade of protection               | IP20   |
|   | Over voltage level                | II   |
|   | Degree of environmental pollution | 2  |
| Class of protection                               | Class I                           |  |
| International certification                       |                                   | CE   |

### Wiring Diagram

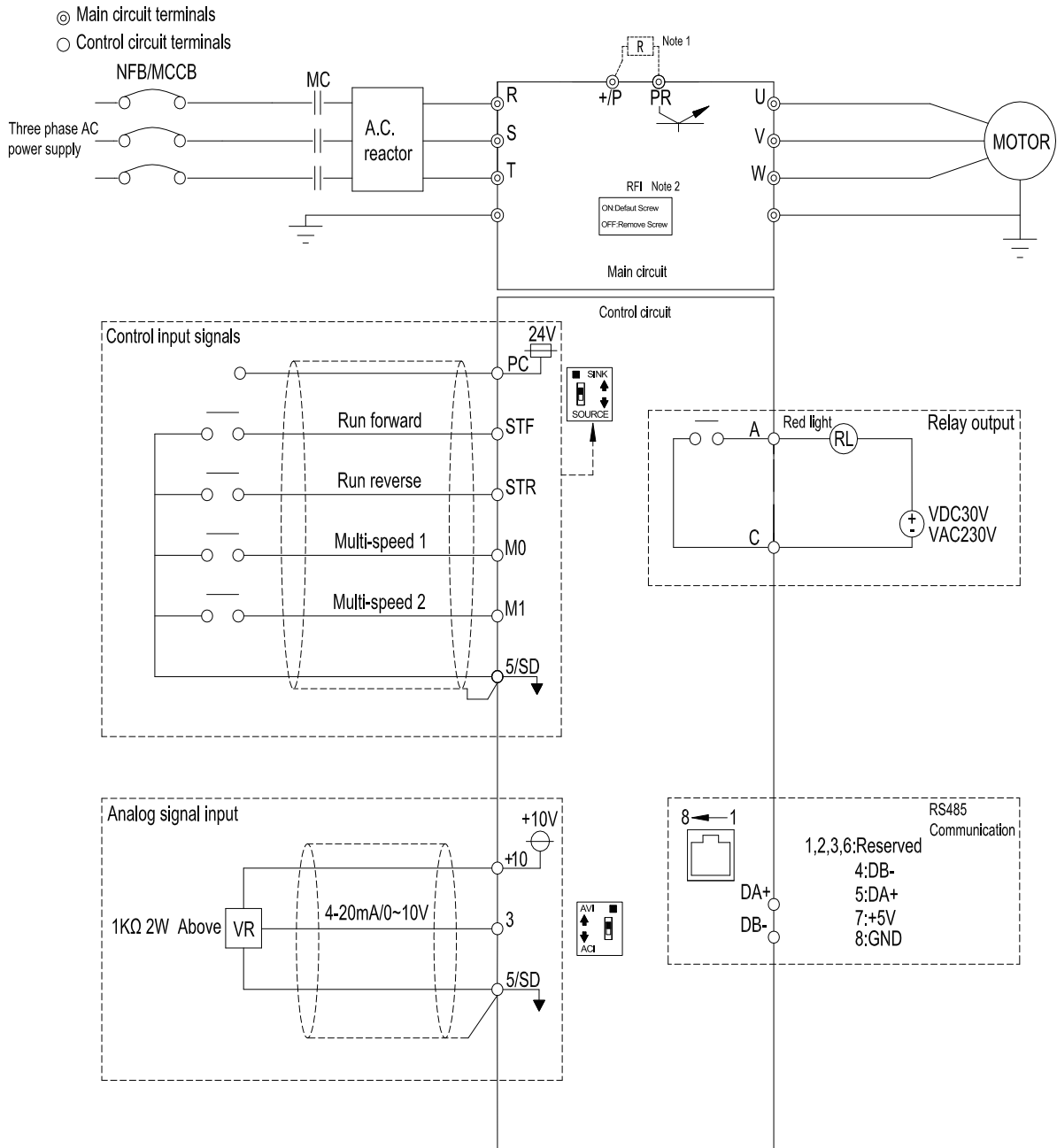

#### NOTE

1. There is no +P and PR terminal in frame A (SC3-043-0.4K~1.5K, SC3-023-0.2K~1.5K, SC3-021-0.2K~0.75K.)
2. All series includes built-in RFI filters, in order to comply with CE regulations, please refer to related parts in this manual.



SC3

## Dimensions

Unit: mm

### Frame A

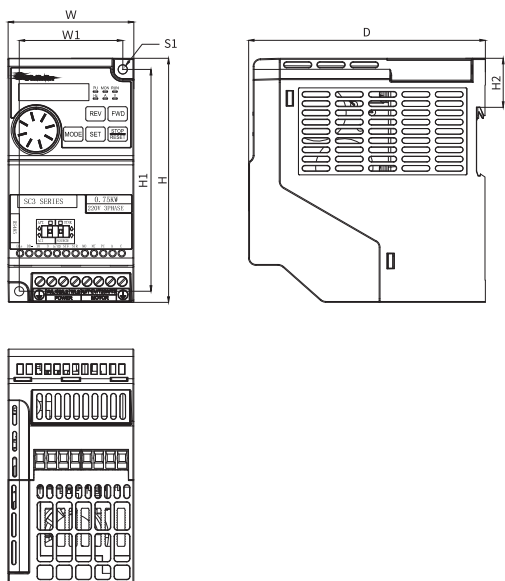

#### Frame A

| Model type    | W (mm) | W1 (mm) | H (mm) | H1 (mm) | H2 (mm) | D (mm) | S1 (mm) |
|---------------|--------|---------|--------|---------|---------|--------|---------|
| SC3-021-0.2K  | 68     | 56      | 132    | 120     | 26.5    | 128    | 5       |
| SC3-021-0.4K  |        |         |        |         |         |        |         |
| SC3-021-0.75K |        |         |        |         |         |        |         |
| SC3-023-0.2K  |        |         |        |         |         |        |         |
| SC3-023-0.4K  |        |         |        |         |         |        |         |
| SC3-023-0.75K |        |         |        |         |         |        |         |
| SC3-023-1.5K  |        |         |        |         |         |        |         |
| SC3-043-0.4K  |        |         |        |         |         |        |         |
| SC3-043-0.75K |        |         |        |         |         |        |         |
| SC3-043-1.5K  |        |         |        |         |         |        |         |

### Frame B

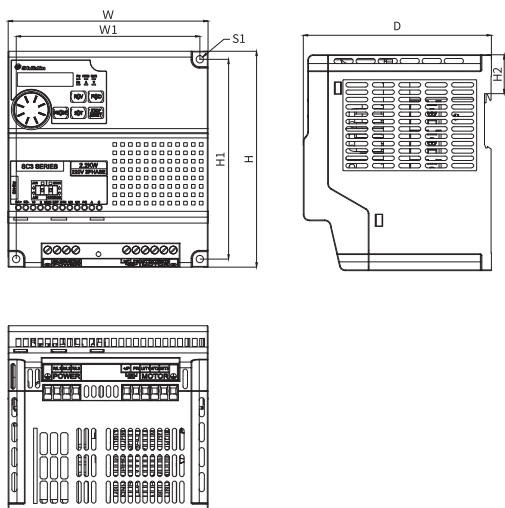

#### Frame B

| Model type   | W (mm) | W1 (mm) | H (mm) | H1 (mm) | H2 (mm) | D (mm) | S1 (mm) |
|--------------|--------|---------|--------|---------|---------|--------|---------|
| SC3-021-1.5K | 136    | 125     | 147    | 136     | 26.5    | 128    | 5       |
| SC3-021-2.2K |        |         |        |         |         |        |         |
| SC3-023-2.2K |        |         |        |         |         |        |         |
| SC3-023-3.7K |        |         |        |         |         |        |         |
| SC3-043-2.2K |        |         |        |         |         |        |         |
| SC3-043-3.7K |        |         |        |         |         |        |         |
| SC3-043-5.5K |        |         |        |         |         |        |         |

# SE3 series

High Speed Closed Loop/  
Communication Inverter

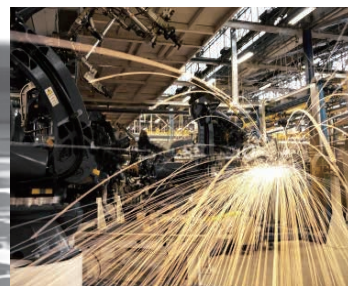

## Power Range

| Model |     | kW (HP)      | 0.4 (0.5) | 0.75 (1) | 1.5 (2) | 2.2 (3) | 3.7 (5) | 5.5 (7.5) | 7.5 (10) | 11 (15) | 15 (20) | 18.5 (25) | 22 (30) |
|-------|-----|--------------|-----------|----------|---------|---------|---------|-----------|----------|---------|---------|-----------|---------|
| SE3   | 021 | 1 phase 220V | ■         |          |         |         |         |           |          |         |         |           |         |
|       | 023 | 3 phase 220V | ■         |          |         |         |         |           |          |         |         |           |         |
|       | 043 | 3 phase 440V | ■         |          |         |         |         |           |          |         |         |           |         |

## Product Features

### High Performance Vector Control Technology

- High starting torque: Sensorless vector control (SVC) 200% 0.5Hz, and closed-loop vector control (FOC + PG) 180% 0Hz.

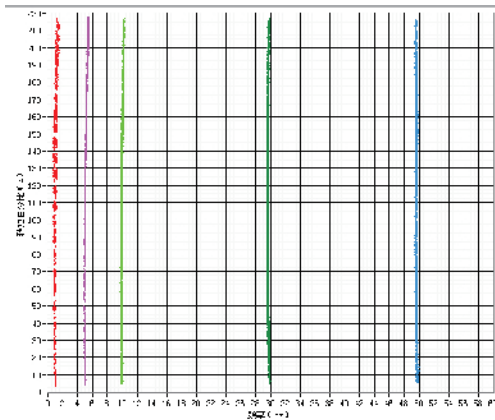

### Up to 1500Hz High-Speed Frequency Output

- Support high speed spindle function, which can be applied to complicated and precise machining process. The application includes high-speed drilling machine, engraving machine, centrifuge equipment.

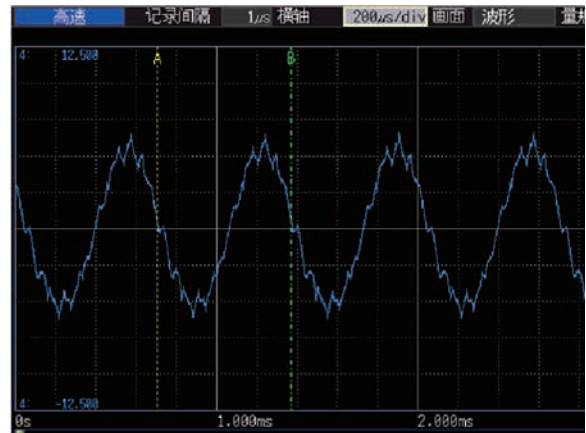

### High Performance Synchronous Motor Control Technology

- Support induction motor (IM) and synchronous motor (IPM and SPM) control.



### Support Multiple High-speed Bus Connections

- Equipped with high-speed communications: CANopen, Profibus, DeviceNet, EtherCAT, MODBUS TCP.



### Product Features

#### Multiple Control Modes for Various Applications

- Position / Speed / Torque / Tension control mode.
- Combination mode (e.g. speed+torque) can be achieved via I/O switch.
- Advanced position control functions: Homing commands, zero speed, Pr/Pt mode(with optional PG cards).

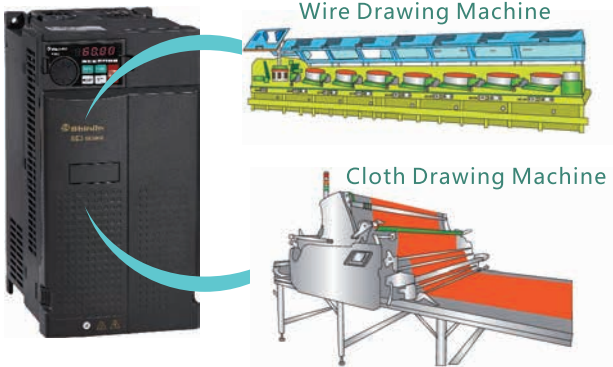

#### Low-noise Carrier Wave Control (Soft-PWM)

- Motor noise is controlled so that the metallic sound is transformed into a more pleasing buzz.
- Low noise operations to reduce the interference exerted upon external radio frequencies.

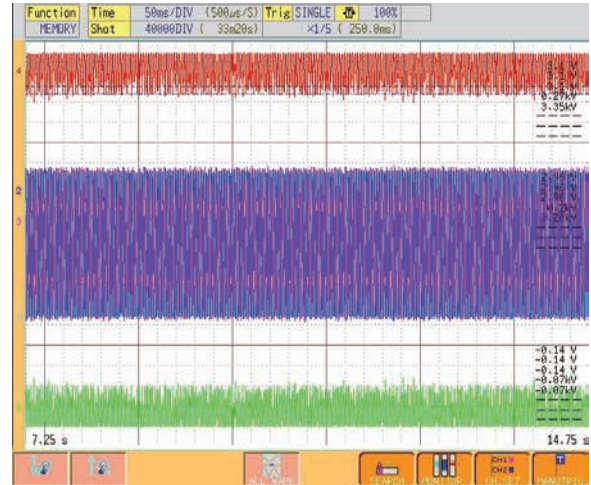

#### Excellent Overload Endurance

- With a current overload capability of 150% for 60 seconds and 200% for 3 seconds, the setting is suitable for handling large sudden load changes applications such as tooling machinery.

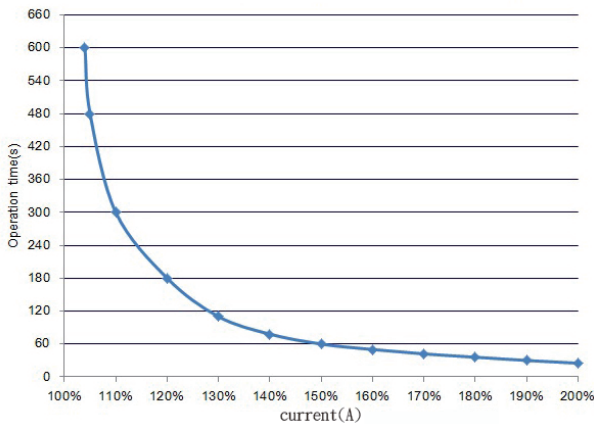

#### Built-in RFI filter

- Reduce electromagnetic interference.

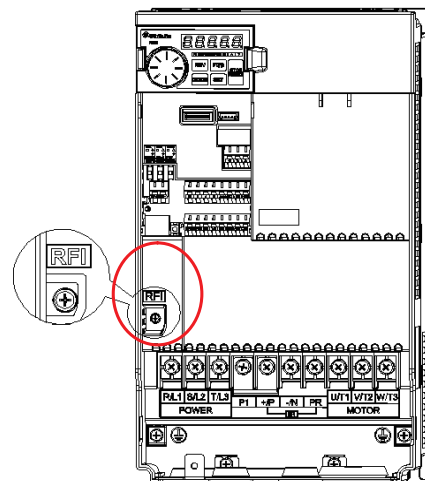

## Product Features

### Isolated Air Channel

- Fan wind channels are sealed and isolated from the heat dissipation system and electrical parts. Dust will not be able to infiltrate the interior of the machine through the fans.

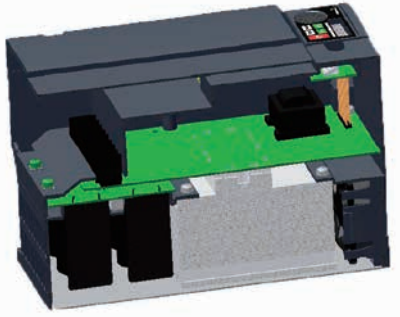

### Complete Protection Functions

- Phase failure protection, overvoltage protection, overcurrent protection, undervoltage protection, output short-circuit protection, ground fault protection, motor overheat protection, IGBT module overheat protection, communication abnormality protection.

### LED Digital Keypad

1. 5-digit 7-segment display
2. Optimized operation JOG Dial



### Quick Connect to External Keypad and Easy Wiring

- Standard RJ45 network and DA+ DB- terminals are equipped for multi-machine communication.

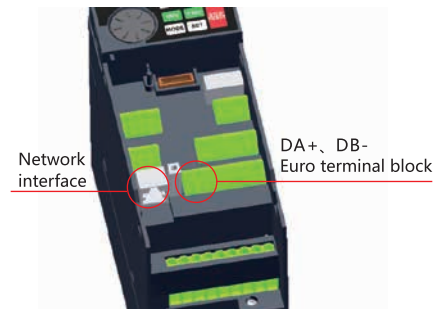

### 12 Sets of Alarm Records

- Complete alarm system for recording the output frequency, output current, output voltage, accumulated count of temperature increase, PN voltage, total operation time, operational status, alarm output time. A total of 12 alarm code, 12 groups of alarm code.

|       |       |                    |      |      |     |
|-------|-------|--------------------|------|------|-----|
| P.288 | 06-40 | Alarm code query   | 0~12 | 0    | 176 |
| P.289 | 06-41 | Alarm code display | Read | Read | 176 |
| P.290 | 06-42 | Alarm code query   | 0~10 | 0    | 176 |
| P.291 | 06-43 | Alarm code display | Read | Read | 176 |

### Built-in PLC Functions

- Provide PLC programming software, easy for editing.
- Applicable for programming small number of points, and support multiple functions.

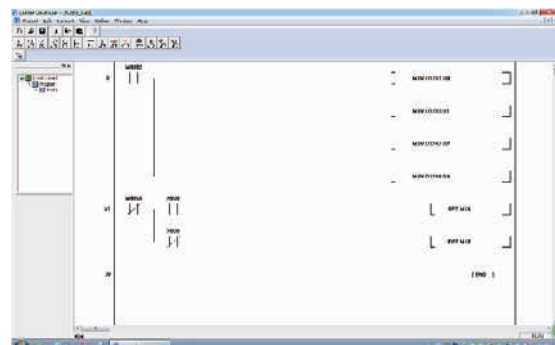

### Product Features

#### Grouping Parameters - Easy Setup

| Group | Parameter Number | Name  | Setting Range  | Default |
|-------|------------------|---|--|---------|
| 02-10 | P.60             | Terminal 2-5 filter time  | 0 ~ 2000ms   | 30ms    |
| 02-11 | P.139            | Terminal 2-5 voltage signal bias rate                           | -100.0%~100.0%   | 0.0%    |
| 02-12 | P.192            | Terminal 2-5 minimum input positive voltage                     | 0 ~ 10.00V   | 0.00V   |
| 02-13 | P.193            | Terminal 2-5 maximum input positive voltage                     | 0 ~ 10.00V   | 10.00V  |
| 02-14 | P.194            | Percentage corresponds to terminal 2-5 minimum positive voltage | -100.0% ~ 100.0%<br>-400.0% ~ 400.0%(02-00(P.500)=2/14/15/16/17) | 0.0%    |

SE3 series: Similar functions are grouped into same sectors instead of sequence numbers.

#### Easy Maintenance

- Minimize dustfall by changing the location of exhaust fan.
- Removable cooling fan for service and regular maintenance.



### Model Identification

| SE3        | 043   | 0.75K    | XY   |
|------------|---|----------|--|
| Series     | Voltage level   | Capacity | Version  |
| SE3 series | 043 : three phase 440V<br>023 : three phase 220V<br>021 : single phase 220V | 0.75kW   | None : General model<br>-xy : Customized or specialized or region difference |



## Electrical Specifications

### 220V series one-phase/three-phase

| Frame                   |   | A  |   | B                  |      |      |
|-------------------------|---|--|---|--------------------|------|------|
| Model SE3-021- □ -xy    |   | 0.4K   | 0.75K   | 1.5K               | 2.2K |      |
| Output                  | HD                                      | Rated output capacity (kVA)                    | 1   | 1.5                | 3.2  | 4.2  |
|                         |   | Rated output current (A)                       | 2.7   | 4.5                | 8    | 11   |
|                         |   | Applicable motor capacity (HP)                 | 0.5   | 1                  | 2    | 3    |
|                         |   | Applicable motor capacity(kW)                  | 0.4   | 0.75               | 1.5  | 2.2  |
|                         |   | Overload current rating                        | 150% 60 seconds 200% 3 seconds (inverse time characteristics) |                    |      |      |
|                         | Carrier frequency (kHz)                 | 1~15kHz  |   |                    |      |      |
|                         | ND                                      | Rated output capacity (kVA)                    | 1.2   | 2                  | 3.4  | 4.8  |
|                         |   | Rated output current (A)                       | 3   | 5                  | 8.5  | 12.5 |
|                         |   | Applicable motor capacity (HP)                 | 0.5   | 1                  | 2    | 3    |
|                         |   | Applicable motor capacity (kW)                 | 0.4   | 0.75               | 1.5  | 2.2  |
| Overload current rating |   | 120% 60 seconds (inverse time characteristics) |   |                    |      |      |
| Carrier frequency (kHz) | 1~15kHz                                 |  |   |                    |      |      |
| Maximum output voltage  |   | Three-phase 200-240V                           |   |                    |      |      |
| Power supply            | Rated power voltage                     | One-phase 200-240V 50Hz / 60Hz                 |   |                    |      |      |
|                         | Power voltage permissible fluctuation   | One -phase 170-264V 50Hz / 60Hz                |   |                    |      |      |
|                         | Power frequency permissible fluctuation | ±5%  |   |                    |      |      |
|                         | Power source capacity (kVA)             | 1.5  | 2.5   | 4.5                | 6.9  |      |
| Cooling method          |   | Self cooling                                   |   | Forced air cooling |      |      |
| Weight(kg)              |   | 1.0  | 1.0   | 1.5                | 1.5  |      |

| Frame                   |   | A   |  |      | B    |      | C    |      | D    |      |      |
|-------------------------|---|---|--|------|------|------|------|------|------|------|------|
| Model SE3-023- □ -xy    |   | 0.4K  | 0.75K  | 1.5K | 2.2K | 3.7K | 5.5K | 7.5K | 11K  | 15K  |      |
| Output                  | HD                                      | Rated output capacity (kVA)                                   | 1.2  | 2    | 3.2  | 4.2  | 6.7  | 9.5  | 12.5 | 18.3 | 24.7 |
|                         |   | Rated output current (A)                                      | 3  | 5    | 8    | 11   | 17.5 | 25   | 33   | 49   | 65   |
|                         |   | Applicable motor capacity (HP)                                | 0.5  | 1    | 2    | 3    | 5    | 7.5  | 10   | 15   | 20   |
|                         |   | Applicable motor capacity(kW)                                 | 0.4  | 0.75 | 1.5  | 2.2  | 3.7  | 5.5  | 7.5  | 11   | 15   |
|                         |   | Overload current rating                                       | 150% 60 seconds 200% 3seconds (inverse time characteristics) |      |      |      |      |      |      |      |      |
|                         | Carrier frequency (kHz)                 | 1~15kHz   |  |      |      |      |      |      |      |      |      |
|                         | ND                                      | Rated output capacity (kVA)                                   | 1.3  | 2.1  | 3.4  | 4.8  | 7.4  | 10.3 | 13.7 | 19.4 | 26.3 |
|                         |   | Rated output current (A)                                      | 3.2  | 5.5  | 8.5  | 12.5 | 19.5 | 27   | 36   | 51   | 69   |
|                         |   | Applicable motor capacity (HP)                                | 0.5  | 1    | 2    | 3    | 5    | 7.5  | 10   | 15   | 20   |
|                         |   | Applicable motor capacity (kW)                                | 0.4  | 0.75 | 1.5  | 2.2  | 3.7  | 5.5  | 7.5  | 11   | 15   |
| Overload current rating |   | 120% 60 seconds 150% 3 seconds (inverse time characteristics) |  |      |      |      |      |      |      |      |      |
| Carrier frequency (kHz) | 1~15kHz                                 |   |  |      |      |      |      |      |      |      |      |
| Maximum output voltage  |   | Three-phase 200-240V  |  |      |      |      |      |      |      |      |      |
| Power supply            | Rated power voltage                     | Three-phase 200-240V 50Hz /60Hz                               |  |      |      |      |      |      |      |      |      |
|                         | Power voltage permissible fluctuation   | Three-phase 170-264V 50Hz/ 60Hz                               |  |      |      |      |      |      |      |      |      |
|                         | Power frequency permissible fluctuation | ±5%   |  |      |      |      |      |      |      |      |      |
|                         | Power source capacity (kVA)             | 1.5   | 2.5  | 4.5  | 6.4  | 10   | 12   | 17   | 20   | 28   |      |
| Cooling method          |   | Forced air cooling  |  |      |      |      |      |      |      |      |      |
| Weight(kg)              |   | 1.0   | 1.0  | 1.0  | 1.5  | 1.5  | 4.0  | 4.1  | 5.7  | 5.8  |      |

**Note:**

The test conditions of rated output current, rated output capacity and inverter power consumption are:the carrier frequency (P.72) is at the set value; the inverter output voltage is at 220V; the output frequency is at 60Hz, and the ambient temperature is 40°C .

### Electrical Specifications

#### 440V series three-phase

| Frame                   |   | A  |   |      | B    |      | C    |      |      | D    |       |      |      |
|-------------------------|---|--|---|------|------|------|------|------|------|------|-------|------|------|
| Model SE3-043- □ -xy    |   | 0.4K   | 0.75K   | 1.5K | 2.2K | 3.7K | 5.5K | 7.5K | 11K  | 15K  | 18.5K | 22K  |      |
| Output                  | HD                                      | Rated output capacity (kVA)                    | 1   | 2    | 3    | 4.6  | 6.9  | 10   | 14   | 18   | 25    | 29   | 34   |
|                         |   | Rated output current (A)                       | 1.5   | 2.7  | 4.2  | 6    | 9    | 12   | 17   | 24   | 32    | 38   | 45   |
|                         |   | Applicable motor capacity (HP)                 | 0.5   | 1    | 2    | 3    | 5    | 7.5  | 10   | 15   | 20    | 25   | 30   |
|                         |   | Applicable motor capacity(kW)                  | 0.4   | 0.75 | 1.5  | 2.2  | 3.7  | 5.5  | 7.5  | 11   | 15    | 18.5 | 22   |
|                         |   | Overload current rating                        | 150% 60 seconds 200% 3 seconds (inverse time characteristics) |      |      |      |      |      |      |      |       |      |      |
|                         | Carrier frequency (kHz)                 | 1~15kHz  |   |      |      |      |      |      |      |      |       |      |      |
|                         | ND                                      | Rated output capacity (kVA)                    | 1.4   | 2.3  | 3.5  | 5    | 8    | 12   | 15.6 | 21.3 | 27.4  | 31.6 | 37.3 |
|                         |   | Rated output current (A)                       | 1.8   | 3    | 4.6  | 6.5  | 10.5 | 15.7 | 20.5 | 28   | 36    | 41.5 | 49   |
|                         |   | Applicable motor capacity (HP)                 | 0.5   | 1    | 2    | 3    | 5    | 7.5  | 10   | 15   | 20    | 25   | 30   |
|                         |   | Applicable motor capacity (kW)                 | 0.4   | 0.75 | 1.5  | 2.2  | 3.7  | 5.5  | 7.5  | 11   | 15    | 18.5 | 22   |
| Overload current rating |   | 120% 60 seconds (inverse time characteristics) |   |      |      |      |      |      |      |      |       |      |      |
| Carrier frequency (kHz) | 1~15kHz                                 |  |   |      |      |      |      |      |      |      |       |      |      |
| Maximum output voltage  |   | Three-phase 380-480V                           |   |      |      |      |      |      |      |      |       |      |      |
| Power supply            | Rated power voltage                     |  | Three-phase 380-480V 50Hz / 60Hz                              |      |      |      |      |      |      |      |       |      |      |
|                         | Power voltage permissible fluctuation   |  | Three-phase 323-528V 50Hz / 60Hz                              |      |      |      |      |      |      |      |       |      |      |
|                         | Power frequency permissible fluctuation |  | ±5%   |      |      |      |      |      |      |      |       |      |      |
|                         | Power source capacity (kVA)             |  | 1.5   | 2.5  | 4.5  | 6.9  | 10.4 | 11.5 | 16   | 20   | 27    | 32   | 41   |
| Cooling method          |   | Self cooling                                   | Forced air cooling  |      |      |      |      |      |      |      |       |      |      |
| Weight(kg)              |   | 1.0  | 1.0   | 1.0  | 1.5  | 1.5  | 3.9  | 4.0  | 4.0  | 5.7  | 5.8   | 5.8  |      |

**Note:**

The test conditions of rated output current, rated output capacity and inverter power consumption are: the carrier frequency (P.72) is at the set value; the inverter output voltage is at 440V; the output frequency is at 60Hz, and the ambient temperature is 40°C .



## Common Specifications

|   |                                       |  |
|---|---------------------------------------|--|
| Control method                                    |                                       | SVPWM control, V/F control, close-loop V/F control (VF+PG), general flux vector control, sensorless vector control (SVC), close-loop vector control (FOC+PG), torque control (TQC+PG).   |
| Output frequency range                            |                                       | 0~1500Hz   |
| Frequency setting resolution                      | Digital setting                       | The resolution is 0.01Hz.  |
|   | Analog setting                        | 0.01Hz/60Hz(terminal 2: -10 ~ +10V / 13bit)<br>0.15Hz/60Hz(terminal 2: 0 ~ ±10V / 12bit)<br>0.03Hz/60Hz(terminal 2: 0 ~ 5V / 11bit)<br>0.06Hz/60Hz(terminal 4: 0~10V, 4-20mA / 12bit)<br>0.12Hz/60Hz(terminal 4: 0 ~ 5V / 11bit)   |
| Output frequency accuracy                         | Digital setting                       | Maximum target frequency±0.01%.  |
|   | Analog setting                        | Maximum target frequency±0.1%.   |
| Speed control range                               |                                       | IM: When SVC, 1:200; when FOC+PG, 1:1000.<br>PM: When SVC, 1:20; when FOC+PG, 1:1000.  |
| Start torque                                      |                                       | 200% 0.5 Hz  |
| V/F characteristics                               |                                       | Constant torque curve, variable torque curve, five-point curve, VF separation  |
| Acceleration / deceleration curve characteristics |                                       | Linear acceleration / deceleration curve, S shape acceleration /deceleration curve   |
| Drive motor                                       |                                       | Induction motor(IM), permanent magnet motor(SPM, IPM)  |
| Stalling protection                               |                                       | The stalling protection level can be set to 0~250%   |
| Target frequency setting                          |                                       | Keypad setting, DC 0~5V / 10V signal, DC -10~+10V signal, DC 4~20 mA signal, multiple speed stage level setting, communication setting, HDI setting.   |
| PID control                                       |                                       | Please refer to parameter description  |
| Built-in simple PLC                               |                                       | Supports 21 basic instructions and 14 application instructions, including PC editing software;   |
| Parameter unit                                    | Operation monitoring                  | Output frequency, output current, output voltage, PN voltage, output torque, electronic thermal accumulation rate, temperature rising accumulation rate, output power, Analog value input signal, digital input and output terminal status... ; alarm signal and alarm history 12 groups at most |
|   | LED indicator (7)                     | Forward rotation indicator, reverse rotation indicator, frequency monitoring indicator, mode switch indicator ,PU control indicator, PLC indicator and run indicator   |
| Communication function                            |                                       | Built-in Shihlin / Modbus communication protocol, can select MODBUS TCP, CANopen, Profibus, DeviceNet, EtherCAT card   |
| Protection mechanism / alarm function             |                                       | Output short circuit protection, Over-current protection, over-voltage protection, under-voltage protection, motor over-heat protection, IGBT module over-heat protection, communication abnormality protection,   |
| Environment                                       | Ambient temperature                   | Heavy load :-10 ~ +50°C (non-freezing) · Light load:-10 ~ +40°C (non-freezing), please refer to 3.4.2 Class of protection and operation temperature for details.   |
|   | Ambient humidity                      | Below 90%Rh (non-condensing).  |
|   | Storage temperature                   | -20 ~ +65°C.   |
|   | Surrounding environment               | Indoor, no corrosive gas, no flammable gas, no flammable powder.   |
|   | Altitude                              | Altitude below 2000 m, when altitude is above 1000 m, derate the rated current 2% per 100 m  |
|   | Vibration                             | Vibration below 5.9m/s <sup>2</sup> (0.6G).  |
|   | Grade of protection                   | IP20   |
|   | The degree of environmental pollution | 2  |
| Class of protection                               |                                       | Class I  |
| International certification                       |                                       | CE   |

### Wiring Diagram

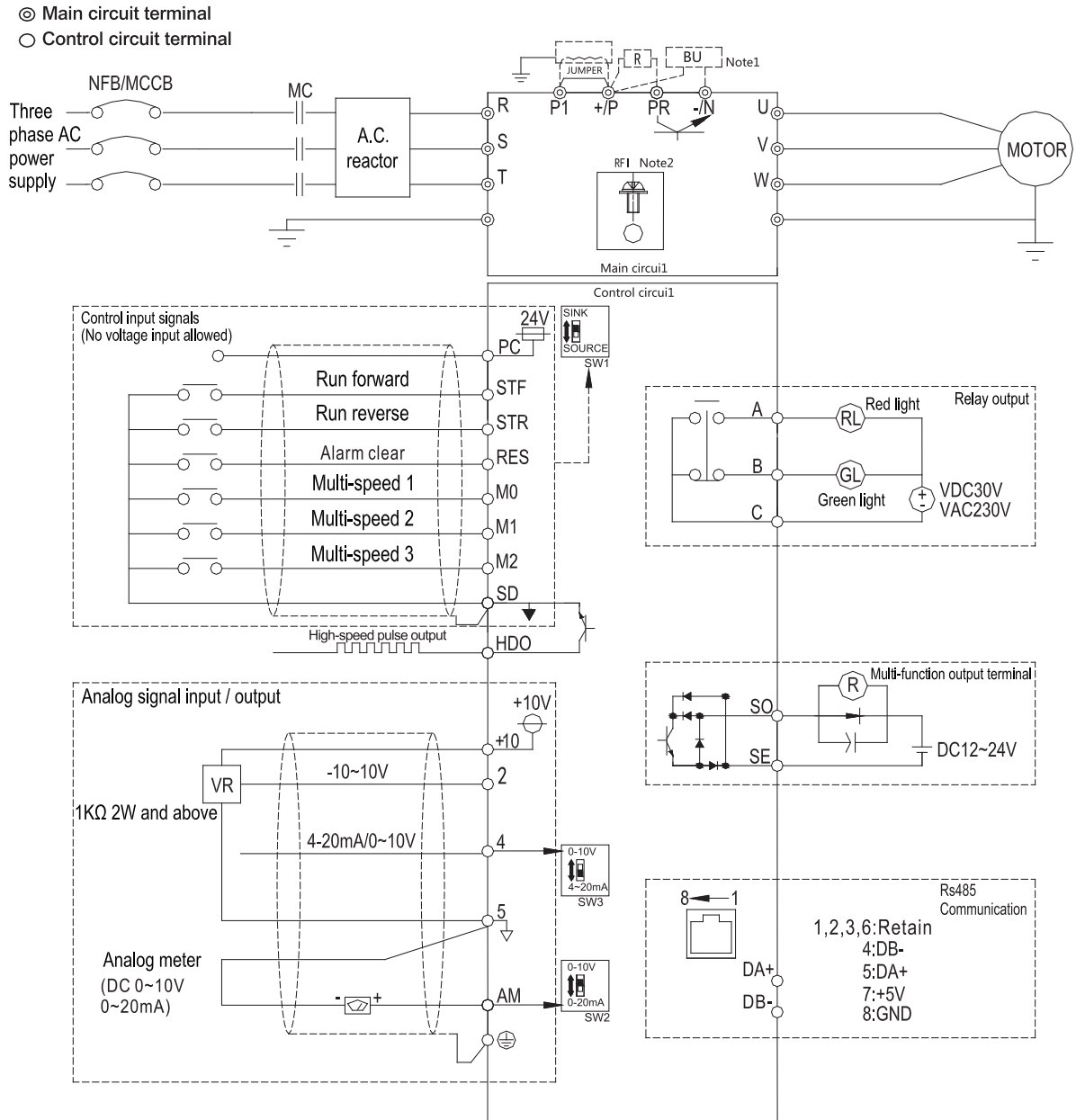

#### NOTE

1. Make sure 10, SD, SE, 5 and PC are not shorted to each other.
2. The DC reactor between +/P and P1 is optional, please short +/P and P1 when DC reactor is not used.

## Dimensions

Unit: mm

### Frame A

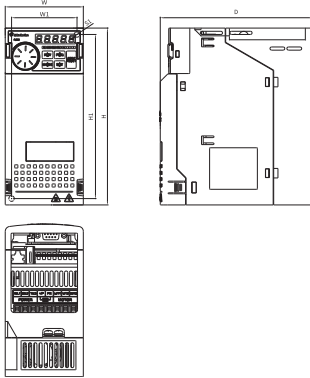

#### Frame A

| Model type        | W (mm) | W1 (mm) | H (mm) | H1 (mm) | D (mm) | S1 (mm) |
|-------------------|--------|---------|--------|---------|--------|---------|
| SE3-043-0.4~1.5K  | 74.0   | 62.0    | 167.0  | 155.0   | 144.0  | 5.2     |
| SE3-023-0.4~1.5K  |        |         |        |         |        |         |
| SE3-021-0.4~0.75K |        |         |        |         |        |         |

### Frame B

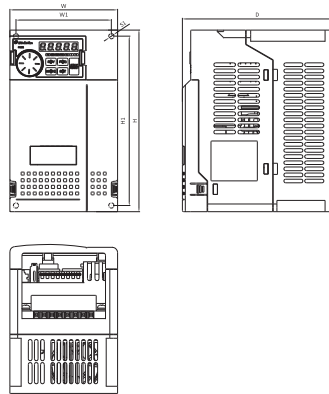

#### Frame B

| Model type       | W (mm) | W1 (mm) | H (mm) | H1 (mm) | D (mm) | S1 (mm) |
|------------------|--------|---------|--------|---------|--------|---------|
| SE3-043-2.2~3.7K | 105.0  | 93.0    | 178.0  | 166.0   | 146.0  | 5.2     |
| SE3-023-2.2~3.7K |        |         |        |         |        |         |
| SE3-021-1.5~2.2K |        |         |        |         |        |         |

### Frame C

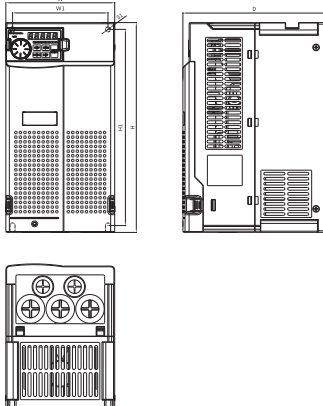

#### Frame C

| Model type       | W (mm) | W1 (mm) | H (mm) | H1 (mm) | D (mm) | S1 (mm) |
|------------------|--------|---------|--------|---------|--------|---------|
| SE3-043-5.5~11K  | 141.0  | 123.6   | 270.0  | 252.6   | 185.0  | 6.5     |
| SE3-023-5.5~7.5K |        |         |        |         |        |         |

### Frame D

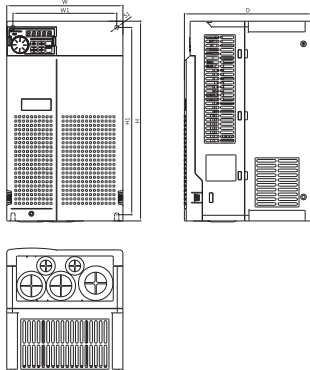

#### Frame D

| Model type     | W (mm) | W1 (mm) | H (mm) | H1 (mm) | D (mm) | S1 (mm) |
|----------------|--------|---------|--------|---------|--------|---------|
| SE3-043-15~22K | 175.0  | 156.4   | 300.0  | 281.4   | 191.8  | 6.2     |
| SE3-023-11~15K |        |         |        |         |        |         |

# SA3 series

Advanced Closed Loop  
Communication Inverter

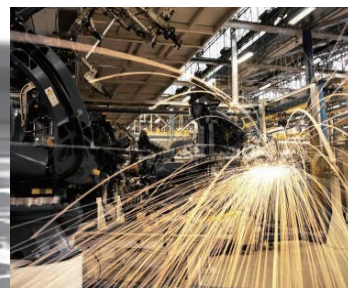

## Product Range

| Model |         | kW (HP)      | 0.75 (1) | 1.5 (2)           | 2.2 (3) | 3.7 (5) | 5.5 (7.5) | 7.5 (10) | 11 (15) | 15 (20) | 18.5 (25) | 22 (30) | 30 (40) | 37 (50) | 45 (60) | 55 (75) | 75 (100) | 90 (120) | 110 (150) | 132 (175) | 160 (215) | 185 (250) | 220 (300) | 250 (335) | 280 (375) | 315 (420) | 355 (475) |  |
|-------|---------|--------------|----------|-------------------|---------|---------|-----------|----------|---------|---------|-----------|---------|---------|---------|---------|---------|----------|----------|-----------|-----------|-----------|-----------|-----------|-----------|-----------|-----------|-----------|--|
| SA3   | SA3-023 | 3 phase 220V | 150%60s  | [Performance bar] |         |         |           |          |         |         |           |         |         |         |         |         |          |          |           |           |           |           |           |           |           |           |           |  |
|       |         |              | 200%3s   | [Performance bar] |         |         |           |          |         |         |           |         |         |         |         |         |          |          |           |           |           |           |           |           |           |           |           |  |
|       | SA3-043 | 3 phase 440V | 150%60s  | [Performance bar] |         |         |           |          |         |         |           |         |         |         |         |         |          |          |           |           |           |           |           |           |           |           |           |  |
|       |         |              | 200%3s   | [Performance bar] |         |         |           |          |         |         |           |         |         |         |         |         |          |          |           |           |           |           |           |           |           |           |           |  |
|       |         |              | 120%60s  | [Performance bar] |         |         |           |          |         |         |           |         |         |         |         |         |          |          |           |           |           |           |           |           |           |           |           |  |

## Product Features

### High Performance Vector Control Technology

- Vector control and Sensorless vector control.
- High starting torque: Sensorless vector control (SVC) 150% 0.3Hz, and closed-loop vector control (FOC + PG) 180% 0Hz.

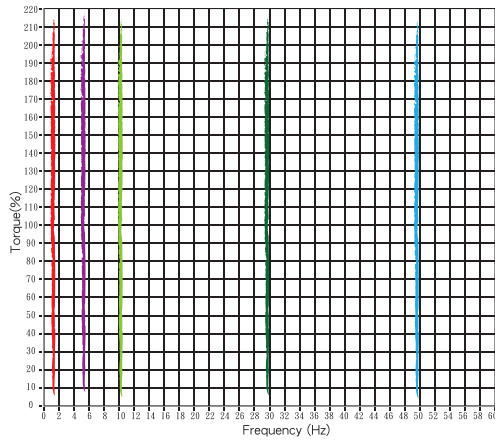

### High Response Performance

- Speed accuracy: less than 1% with 0 to 100% load variation.
- For applications with sudden load changes such as cranes and metal processing machinery.

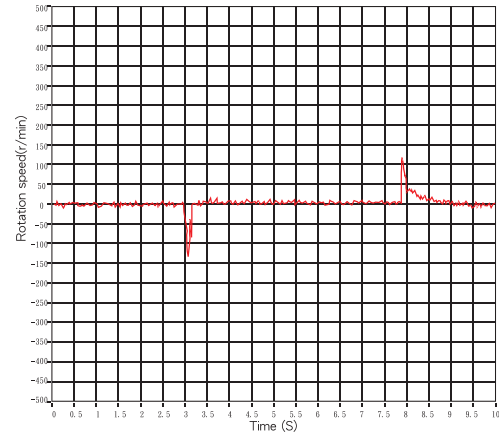

### Excellent Overload Endurance

- With a current overload capability of 150% for 60 seconds and 200% for 3 seconds, the setting is suitable for handling large sudden load changes applications such as tooling machinery.

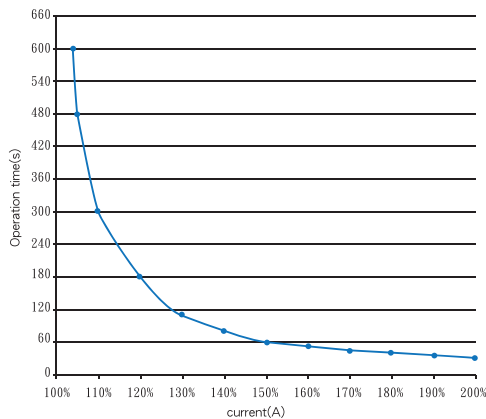

### 4-Quadrant Torque Control and Limits

- Parameters or analog signals can be used to simply establish limits for 4 torque items.

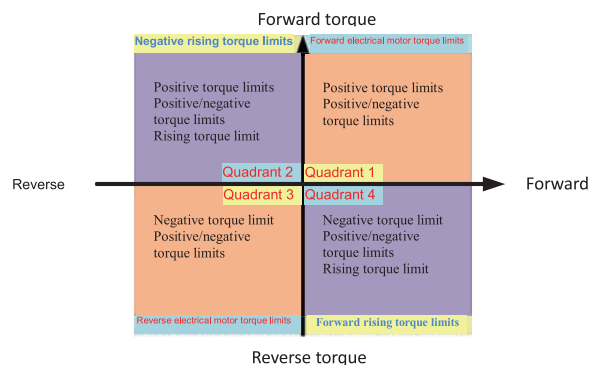

### Product Features

#### Temporary Compensation at Low Voltage

- When temporary shut-down occurs, output frequency will be controlled to maintain DC bus voltage of the inverter to decelerate the motor.
- When power resumes, inverter will control the motor to accelerate to its previous speed.
- Applicable for machines that are not able to commence free-run while decelerating.

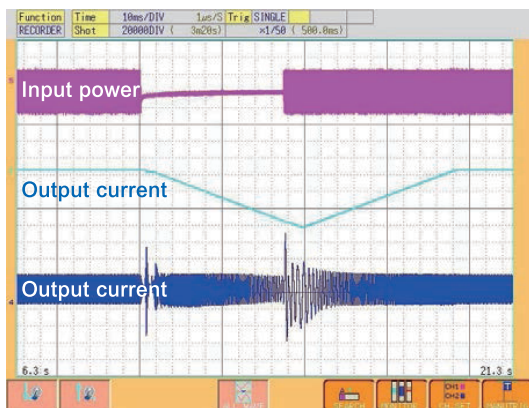

#### Magnetic Flux Brake

- When the motor is stopping, the magnetic flux will be transmitted to the motor coil to shorten deceleration time without relying on regenerative resistance.

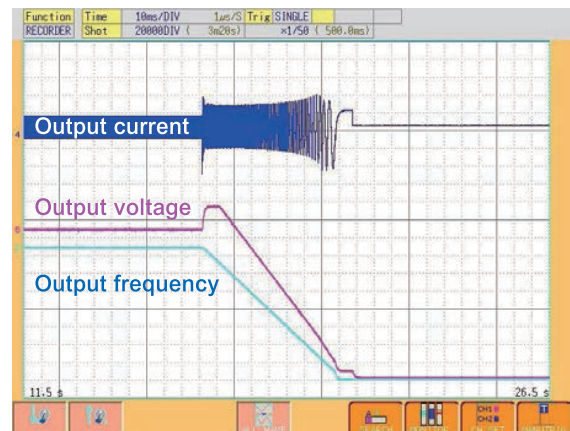

#### Regeneration Avoidance Functions

- By adjusting output frequency and voltage, DC bus voltage can be kept at a specified value and prevent overvoltage.

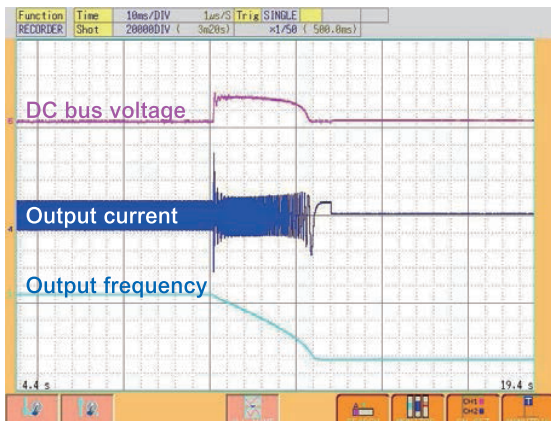

#### Low-noise Carrier Wave Control (Soft-PWM)

- Motor noise is controlled so that the metallic sound is transformed into a more pleasing buzz.
- Low noise operations to reduce the interference exerted upon external radio frequencies.

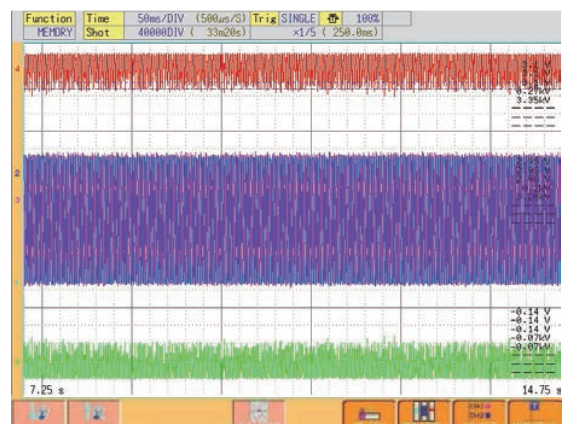



SA3

## Product Features

### Advanced Synchronous Motors Control Technology

- Support both induction and permanent magnet motors with open-loop control.



### LCD Operation Interface

- Support 2 display styles.
- Able to simultaneously display 6 sets of operational data.
- Calendar support.
- Offer both English and Chinese language interfaces.
- Capable of storing 3 sets of parameters.
- Support shuttle settings.



### Isolated Air Channel

- Fan wind channels are sealed and isolated from the heat dissipation system and electrical parts. Dust will not be able to infiltrate the interior of the machine through the fans.

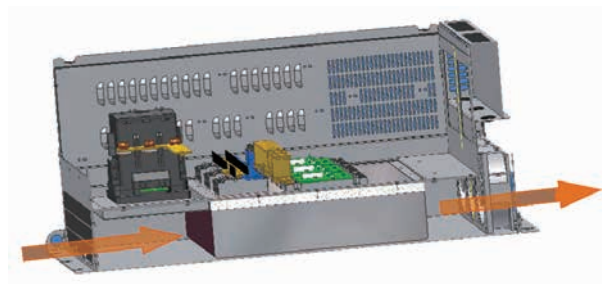

### Multiple Control Modes for Various Applications

- Position / Speed / Torque / Tension control mode
- Combination mode (e.g. speed+torque) can be achieved via I/O switch.
- Advanced position control functions: Homing commands, zero speed, Pr/Pt mode(with optional PG cards).
- Support open-loop tension control, feeding disruption inspection and automatic spool replacement functions.

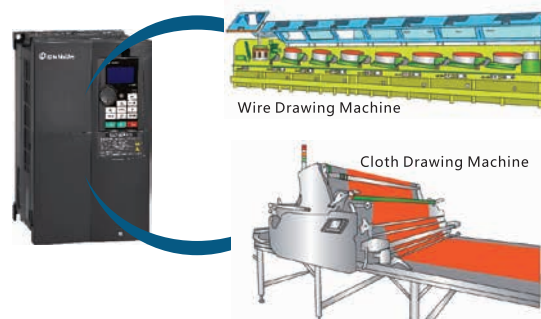

### Product Features

#### Multiple I/O Terminals

- Include 10 sets of multi-functional combinational logic input terminals (with high-speed pulse inputs \*1)
- Include 5 sets of multi-functional combinational output terminals (including electric relay output \*2, transistor output \*2, and high-speed pulse output \*1).
- Include 3 sets of analog input signals (with -10~+10V\*1 and 4~20mA/0~10V\*2).
- Include 2 sets of analog output signals (0~20mA/0~10V\*2).
- 1 set of safety switch (S1~SC).

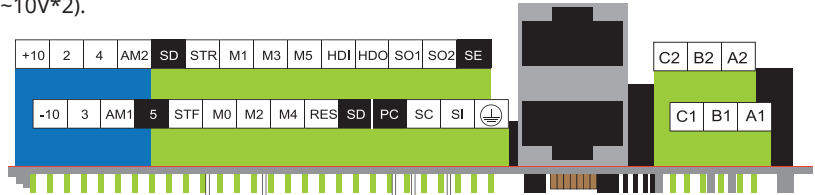

#### Built-in PLC Functions

- Provide PLC programming software, easy for editing.
- Applicable for programming small number of points, and support multiple functions.

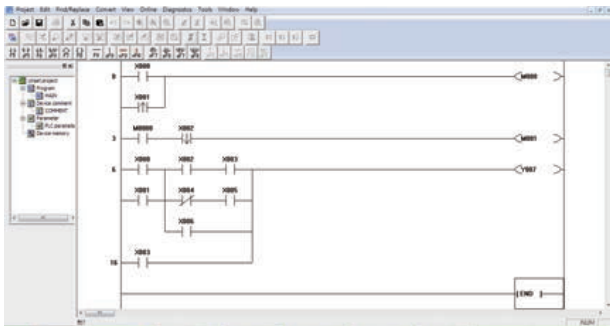

| Item                          | SA3 PLC functions                        |  |
|-------------------------------|--|--|
| Programming Language          | Ladder diagram + Command                 |  |
| Basic commands                | 21                                       |  |
| Applicable commands           | 14                                       |  |
| Processing speed              | Basic commands                           | 1 μs   |
|                               | Applicable commands                      | 10 μs  |
| Hidden program capacity       | 400 steps(0-399 steps)                   |  |
| I/O configuration             | Input(X)                                 | 22 points(X0-X25, octal)                       |
|                               | Output(Y)                                | 20 points(Y0-Y23, octal)                       |
| Supporting electric relay (M) | General                                  | 160 points, MO-M159                            |
|                               | Battery backed                           | 80 points, M160-M239                           |
| Timer(T)                      | Special                                  | 64 points, M8000-M8063                         |
|                               | 100ms                                    | 8 points, TO-T7, timer range: 0-6553.5 seconds |
| Counter(C)                    | 8 points, CO-C7, counting range: 0-65535 |  |
| Data register                 | General                                  | 32 points, D0-D31                              |
|                               | Battery backed                           | 16 points, D32-D47                             |
|                               | Special                                  | 64 points, D8000-D8063                         |

#### Through-the-wall Installation Support Provided for the Entire Series

- Improve heat dissipation, reduce heat generation within the cabinet, and improve protection for the cabinet contents.

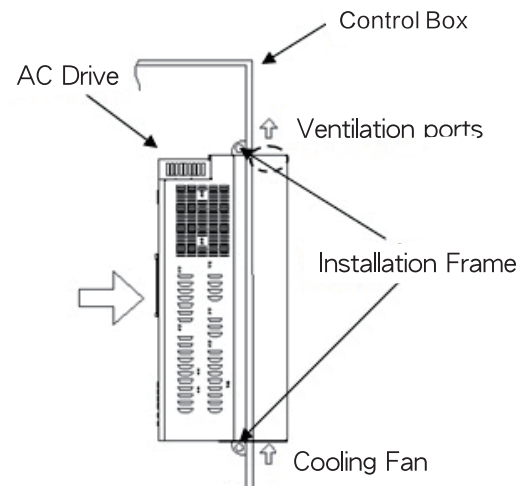

#### 12 Sets of Alarm Records

- Complete alarm system for recording the output frequency, output current, output voltage, accumulated count of temperature increase, PN voltage, total operation time, operational status, alarm output time(only when used with PU301C).

#### Improved Protection

- Output phase failure protection, output short circuit protection, ground leakage protection, low voltage protection, motor overheating signal (PTC), and electrolytic capacitor life inspection.

#### Built-in RFI filter

- Reduce electromagnetic interference.

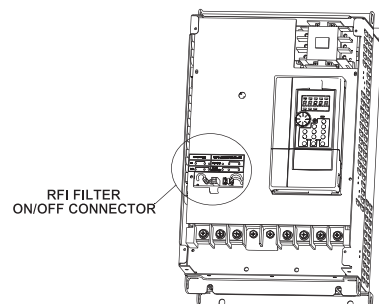



## Model Identification

**SA3**      **043 0.75K/1.5KF**      **XY**

| Series     | Voltage level                                    | Capacity                  | Version  |
|------------|--|---------------------------|--|
| SA3 series | 043 : three phase 440V<br>023 : three phase 220V | HD : 0.75kW<br>ND : 1.5kW | None : General model<br>-xy : Customized or specialized or region difference |

## Electrical Specifications

### 220V Three-phase Series

| Frame                                   |  | A   |               |               |               | B             |              |             | C             |               | D           |             | E           |             | F           |             | G            |               |  |
|---|--|---|---------------|---------------|---------------|---------------|--------------|-------------|---------------|---------------|-------------|-------------|-------------|-------------|-------------|-------------|--------------|---------------|--|
| Model SA3-023- □ -xy                    |  | 075K<br>1.5KF   | 1.5K<br>2.2KF | 2.2K<br>3.7KF | 3.7K<br>5.5KF | 5.5K<br>7.5KF | 7.5K<br>11KF | 11K<br>15KF | 15K<br>18.5KF | 18.5K<br>22KF | 22K<br>30KF | 30K<br>37KF | 37K<br>45KF | 45K<br>55KF | 55K<br>75KF | 75K<br>90KF | 90K<br>110KF | 110K<br>132KF |  |
| Output                                  | Rated output capacity (kVA)                    | 2   | 3.2           | 4.2           | 6.7           | 9.5           | 12.5         | 18.3        | 24.7          | 28.6          | 34.3        | 45.7        | 55          | 65          | 82          | 110         | 132          | 165           |  |
|   | Rated output current (A)                       | 5   | 8             | 11            | 17.5          | 25            | 33           | 49          | 65            | 75            | 90          | 120         | 145         | 170         | 215         | 288         | 346          | 432           |  |
|   | Applicable motor capacity (HP)                 | 1   | 2             | 3             | 5             | 7.5           | 10           | 15          | 20            | 25            | 30          | 40          | 50          | 60          | 75          | 100         | 120          | 145           |  |
|   | Applicable motor capacity (kW)                 | 0.75  | 1.5           | 2.2           | 3.7           | 5.5           | 7.5          | 11          | 15            | 18.5          | 22          | 30          | 37          | 45          | 55          | 75          | 90           | 110           |  |
|   | Overload current rating                        | 150% 60 seconds 200% 3 seconds (inverse time characteristics) |               |               |               |               |              |             |               |               |             |             |             |             |             |             |              |               |  |
|   | Carrier frequency (kHz)                        | 1~15kHz   |               |               |               |               |              |             |               |               | 1~9kHz      |             |             |             |             |             |              |               |  |
|   | Rated output capacity (kVA)                    | 3.2   | 4.2           | 6.7           | 9.5           | 12.5          | 18.3         | 24.7        | 28.6          | 34.3          | 45.7        | 55          | 65          | 82          | 110         | 132         | 165          | 193           |  |
|   | Rated output current (A)                       | 8   | 11            | 17.5          | 25            | 33            | 49           | 65          | 75            | 90            | 120         | 145         | 170         | 215         | 288         | 346         | 432          | 506           |  |
|   | Applicable motor capacity (HP)                 | 2   | 3             | 5             | 7.5           | 10            | 15           | 20          | 25            | 30            | 40          | 50          | 60          | 75          | 100         | 120         | 145          | 175           |  |
|   | Applicable motor capacity (kW)                 | 1.5   | 2.2           | 3.7           | 5.5           | 7.5           | 11           | 15          | 18.5          | 22            | 30          | 37          | 45          | 55          | 75          | 90          | 110          | 132           |  |
| Overload current rating                 | 120% 60 seconds (inverse time characteristics) |   |               |               |               |               |              |             |               |               |             |             |             |             |             |             |              |               |  |
| Carrier frequency (kHz)                 | 1~15kHz  |   |               |               |               |               |              |             |               | 1~9kHz        |             |             |             |             |             |             |              |               |  |
| Maximum output voltage                  | Three-phase 200-240V                           |   |               |               |               |               |              |             |               |               |             |             |             |             |             |             |              |               |  |
| Rated power voltage                     | Three-phase 200-240V 50Hz / 60Hz               |   |               |               |               |               |              |             |               |               |             |             |             |             |             |             |              |               |  |
| Power voltage permissible fluctuation   | Three-phase 170-264V 50Hz / 60Hz               |   |               |               |               |               |              |             |               |               |             |             |             |             |             |             |              |               |  |
| Power frequency permissible fluctuation | ±5%  |   |               |               |               |               |              |             |               |               |             |             |             |             |             |             |              |               |  |
| Power source capacity (kVA)             | 2.5  | 4.5   | 6.4           | 10            | 12            | 17            | 20           | 28          | 34            | 41            | 52          | 65          | 79          | 100         | 110         | 132         | 165          |               |  |
| Cooling method                          | Self cooling                                   | Forced air cooling  |               |               |               |               |              |             |               |               |             |             |             |             |             |             |              |               |  |
| Weight(kg)                              | 3.15   | 3.15  | 3.15          | 3.15          | 6             | 6             | 6            | 10.6        | 10.6          | 33            | 33          | 33          | 42.7        | 42.7        | 56.5        | 89.2        | 90.2         |               |  |

Note:

The test conditions of rated output current, rated output capacity and inverter power consumption are: the carrier frequency (P.72) is at the set value; the inverter output voltage is at 220V; the output frequency is at 60Hz, and the ambient temperature is 40°C.

### Electrical Specifications

#### 440 V Three-phase Series

| Frame                   |   | A  |   |               |               |               | B            |             |               | C             |             |             | D           |    |
|-------------------------|---|--|---|---------------|---------------|---------------|--------------|-------------|---------------|---------------|-------------|-------------|-------------|----|
| Model SA3-043- □ -xy    |   | 0.75K<br>1.5KF                                 | 1.5K<br>2.2KF   | 2.2K<br>3.7KF | 3.7K<br>5.5KF | 5.5K<br>7.5KF | 7.5K<br>11KF | 11K<br>15KF | 15K<br>18.5KF | 18.5K<br>22KF | 22K<br>30KF | 30K<br>37KF | 37K<br>45KF |    |
| Output                  | HD                                      | Rated output capacity (kVA)                    | 2   | 3             | 4.6           | 6.9           | 10           | 14          | 18            | 25            | 29          | 34          | 46          | 56 |
|                         |   | Rated output current (A)                       | 3.0   | 4.2           | 6             | 9             | 12           | 17          | 24            | 32            | 38          | 45          | 60          | 73 |
|                         |   | Applicable motor capacity (HP)                 | 1   | 2             | 3             | 5             | 7.5          | 10          | 15            | 20            | 25          | 30          | 40          | 50 |
|                         |   | Applicable motor capacity(kW)                  | 0.75  | 1.5           | 2.2           | 3.7           | 5.5          | 7.5         | 11            | 15            | 18.5        | 22          | 30          | 37 |
|                         |   | Overload current rating                        | 150% 60 seconds 200% 3 seconds (inverse time characteristics) |               |               |               |              |             |               |               |             |             |             |    |
|                         | Carrier frequency (kHz)                 | 1~15kHz  |   |               |               |               |              |             |               |               |             |             |             |    |
|                         | ND                                      | Rated output capacity (kVA)                    | 3   | 4.6           | 6.9           | 10            | 14           | 18          | 25            | 29            | 34          | 46          | 56          | 69 |
|                         |   | Rated output current (A)                       | 4.2   | 6             | 9             | 12            | 17           | 24          | 32            | 38            | 45          | 60          | 73          | 91 |
|                         |   | Applicable motor capacity (HP)                 | 2   | 3             | 5             | 7.5           | 10           | 15          | 20            | 25            | 30          | 40          | 50          | 60 |
|                         |   | Applicable motor capacity (kW)                 | 1.5   | 2.2           | 3.7           | 5.5           | 7.5          | 11          | 15            | 18.5          | 22          | 30          | 37          | 45 |
| Overload current rating |   | 120% 60 seconds (inverse time characteristics) |   |               |               |               |              |             |               |               |             |             |             |    |
| Carrier frequency (kHz) | 1~15kHz                                 |  |   |               |               |               |              |             |               |               |             |             |             |    |
| Maximum output voltage  |   | Three-phase 380-480V                           |   |               |               |               |              |             |               |               |             |             |             |    |
| Power supply            | Rated power voltage                     | Three-phase 380-480V 50Hz / 60Hz               |   |               |               |               |              |             |               |               |             |             |             |    |
|                         | Power voltage permissible fluctuation   | Three-phase 342-528V 50Hz / 60Hz               |   |               |               |               |              |             |               |               |             |             |             |    |
|                         | Power frequency permissible fluctuation | ±5%  |   |               |               |               |              |             |               |               |             |             |             |    |
|                         | Power source capacity (kVA)             | 2.5  | 4.5   | 6.9           | 10.4          | 11.5          | 16           | 20          | 27            | 32            | 41          | 52          | 65          |    |
| Cooling method          |   | Self cooling                                   | Forced air cooling  |               |               |               |              |             |               |               |             |             |             |    |
| Weight(kg)              |   | 3.15   | 3.15  | 3.15          | 3.15          | 3.15          | 6            | 6           | 6             | 9.8           | 9.8         | 9.8         | 33          |    |

| Frame                   |   | D  |  |             | E            | F             | G             |               |               |               | H             |               |               |     |
|-------------------------|---|--|--|-------------|--------------|---------------|---------------|---------------|---------------|---------------|---------------|---------------|---------------|-----|
| Model SA3-043- □ -xy    |   | 45K<br>55KF                                    | 55K<br>75KF  | 75K<br>90KF | 90K<br>110KF | 110K<br>132KF | 132K<br>160KF | 160K<br>185KF | 185K<br>220KF | 220K<br>250KF | 250K<br>280KF | 280K<br>315KF | 315K<br>355KF |     |
| Output                  | HD                                      | Rated output capacity (kVA)                    | 69   | 84          | 114          | 137           | 168           | 198           | 236           | 295           | 367           | 402           | 438           | 491 |
|                         |   | Rated output current (A)                       | 91   | 110         | 150          | 180           | 220           | 260           | 310           | 340           | 425           | 480           | 530           | 620 |
|                         |   | Applicable motor capacity (HP)                 | 60   | 75          | 100          | 120           | 150           | 175           | 215           | 250           | 300           | 335           | 375           | 420 |
|                         |   | Applicable motor capacity(kW)                  | 45   | 55          | 75           | 90            | 110           | 132           | 160           | 185           | 220           | 250           | 280           | 315 |
|                         |   | Overload current rating                        | 150% 60 seconds 200% 3seconds (inverse time characteristics) |             |              |               |               |               |               |               |               |               |               |     |
|                         | Carrier frequency (kHz)                 | 1~9kHz   |  |             |              |               |               |               |               |               |               |               |               |     |
|                         | ND                                      | Rated output capacity (kVA)                    | 84   | 114         | 137          | 168           | 198           | 236           | 295           | 367           | 402           | 438           | 491           | 544 |
|                         |   | Rated output current (A)                       | 110  | 150         | 180          | 220           | 260           | 310           | 340           | 425           | 480           | 530           | 620           | 683 |
|                         |   | Applicable motor capacity (HP)                 | 75   | 100         | 120          | 150           | 175           | 215           | 250           | 300           | 335           | 375           | 420           | 475 |
|                         |   | Applicable motor capacity (kW)                 | 55   | 75          | 90           | 110           | 132           | 160           | 185           | 220           | 250           | 280           | 315           | 355 |
| Overload current rating |   | 120% 60 seconds (inverse time characteristics) |  |             |              |               |               |               |               |               |               |               |               |     |
| Carrier frequency (kHz) | 1~9kHz                                  |  |  |             |              |               |               |               |               |               |               |               |               |     |
| Maximum output voltage  |   | Three-phase 380-480V                           |  |             |              |               |               |               |               |               |               |               |               |     |
| Power supply            | Rated power voltage                     | Three-phase 380-480V 50Hz / 60Hz               |  |             |              |               |               |               |               |               |               |               |               |     |
|                         | Power voltage permissible fluctuation   | Three-phase 342-528V 50Hz / 60Hz               |  |             |              |               |               |               |               |               |               |               |               |     |
|                         | Power frequency permissible fluctuation | ±5%  |  |             |              |               |               |               |               |               |               |               |               |     |
|                         | Power source capacity (kVA)             | 79   | 100  | 110         | 137          | 165           | 198           | 247           | 295           | 367           | 402           | 438           | 491           |     |
| Cooling method          |   | Self cooling                                   | Forced air cooling   |             |              |               |               |               |               |               |               |               |               |     |
| Weight(kg)              |   | 33   | 33   | 33          | 42.7         | 42.7          | 56.5          | 84            | 84            | 84            | 84            | 123           | 123           |     |

**Note:**

The test conditions of rated output current, rated output capacity and inverter power consumption are: the carrier frequency (P.72) is at the set value; the inverter output voltage is at 440V; the output frequency is at 60Hz, and the ambient temperature is 40°C.



SA3

## Common Specifications

|   |                                       |  |
|---|---------------------------------------|--|
| Control method                                    |                                       | SVPWM control, V/F control, close-loop V/F control (VF+PG), general flux vector control, sensorless vector control (SVC), close-loop vector control (FOC+PG), torque control (TQC+PG).   |
| Output frequency range                            |                                       | 0~599.00Hz   |
| Frequency setting resolution                      | Digital setting                       | The resolution is 0.01Hz.  |
|   | Analog setting                        | 0.01Hz/60Hz (terminal 2: -10 ~ +10V / 13bit)<br>0.015Hz/60Hz (terminal 2: 0 ~ ±10V / 12bit; terminal 3: 0~10V, 4-20mA / 12bit)<br>0.03Hz/60Hz (terminal 2, 3: 0 ~ 5V / 11bit)<br>0.06Hz/60Hz (terminal 4: 0~10V, 4-20mA /10bit)<br>0.12Hz/60Hz (terminal 4: 0 ~ 5V /9bit)  |
| Output frequency accuracy                         | Digital setting                       | Maximum target frequency ± 0.01%.  |
|   | Analog setting                        | Maximum target frequency ± 0.1%.   |
| Speed control range                               |                                       | IM: When SVC, 1:200; when FOC+PG, 1:1000.<br>PM: When SVC, 1:20; when FOC+PG, 1:1000.  |
| Start torque                                      |                                       | 150% 0.3Hz (SVC), 180% 0Hz (FOC+PG).   |
| V/F characteristics                               |                                       | Constant torque curve, variable torque curve, five-point curve, VF separation  |
| Acceleration / deceleration curve characteristics |                                       | Linear acceleration / deceleration curve, S shape acceleration / deceleration curve1 & 2 & 3   |
| Drive motor                                       |                                       | Induction motor (IM), permanent magnet motor(SPM, IPM)   |
| Stalling protection                               |                                       | The stalling protection level can be set to 0~400% (06-01(P.22)). The default value is 150%.   |
| Target frequency setting                          |                                       | Keypad setting, DC 0~5V/10V signal, DC -10~+10V signal, DC 4~20 mA signal, multi-speed stage level setting, communication setting, HDI setting.  |
| PID control                                       |                                       | Please refer to 08-00~08-01 ~ 08-04~08-14 / P.170~P.182 in chapter 4.  |
| Built-in simple PLC                               |                                       | Supports 21 basic instructions and 14 application instructions, including PC editing software;   |
| Operation Panel                                   | Operation monitoring                  | Output frequency, output current, output voltage, PN voltage, output torque, electronic thermal accumulation rate, temperature rising accumulation rate, output power, analog value input signal, digital input and output terminal status...; alarm history 12 groups at most, the last group of alarm message is recorded.   |
|   | LED indicator (10)                    | Forward rotation indicator, reverse rotation indicator, frequency monitoring indicator, voltage monitoring indicator, current monitoring dedicator, NET dedicator, PU control indicator, EXT indicator, PLC indicator and MON monitoring indicator.  |
| Communication function                            |                                       | RS-485 communication, can select Shihlin/Modbus communication protocol, communication speed up to 115200bps, built-in CanOpen protocol (with CP301 expansion card), double RJ-45 connectors (the connector can also be connected to keypad)  |
| Protection mechanism / alarm function             |                                       | Output short circuit protection, Over-current protection, over-voltage protection, under-voltage protection, motor over-heat protection (06-00(P.9)), IGBT module over-heat protection, communication abnormality protection, PTC temperature protection etc, electrolytic capacitor overheat, input and output phase failure, to-earth (ground) leakage currents protection, circuit error detection...   |
| Environment                                       | Ambient temperature                   | Heavy duty : -10 ~ +50°C (non-freezing), Light duty : -10 ~ +40°C (non-freezing), please refer to 3.4.5 Class of protection and operation temperature for details.   |
|   | Ambient humidity                      | Below 90%Rh (non-condensing).  |
|   | Storage temperature                   | -20 ~ +65°C  |
|   | Surrounding environment               | Indoor, no corrosive gas, no flammable gas, no flammable powder.   |
|   | Altitude                              | Altitude below 3000 meters, when altitude is above 1,000 m, derate the rated current 2% per 100 m<br>Note 1: According to the safety regulation EN61800-5-1, which is required to declare in CE certification, this series of inverters can be installed in an environment of over-voltage class II when the altitude is less than 3000m. When the altitude is less than 2000m, can be installed in harsher conditions that meet the requirements of over-voltage class III. |
|   | Vibration                             | Vibration below 5.9m/s <sup>2</sup> (0.6G)   |
|   | Grade of protection                   | Frame A, B, C, IP20 / NEMA TYPE 1, Frame D and above IP00 / UL OPEN TYPE (optional IP20 accessories can be added).   |
|   | The degree of environmental pollution | 2  |
| Class of protection                               |                                       | Class I  |
| International certification                       |                                       | CE   |

### Wiring Diagram

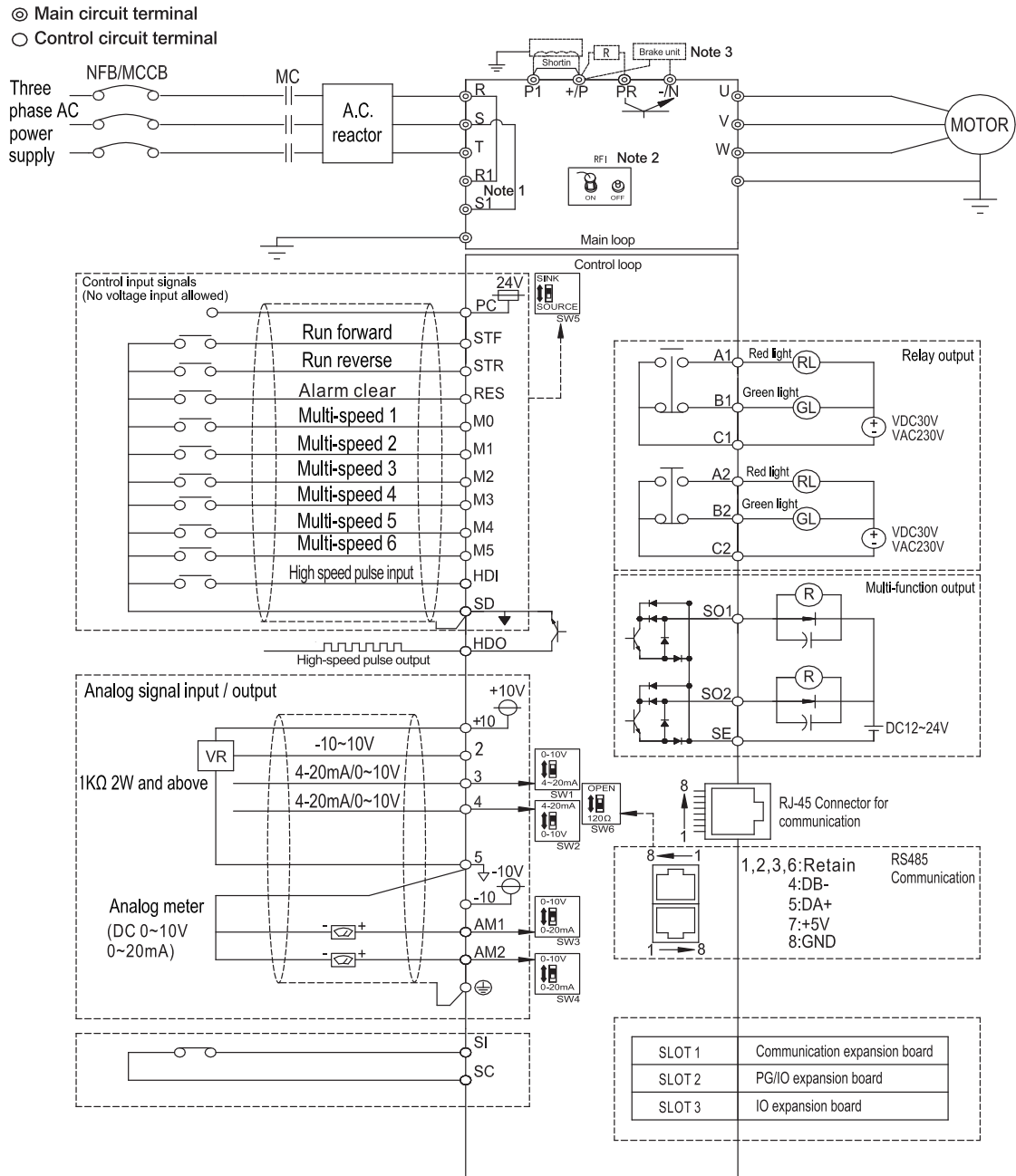

#### NOTE

- R1 S1 terminal is only for frame D~H.
- +/P PR is for frame A B C, for frame D and above need to add brake unit.
- The DC reactor between + / P and P1 is optional, please short + / P and P1 when DC reactor is not used.



SA3

## Dimensions

Unit: mm

Frame A

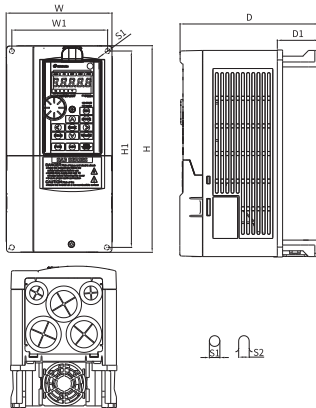

Frame A

| Model type          | W (mm) | W1 (mm) | H (mm) | H1 (mm) | D (mm) | D1 (mm) | S1 (mm) | S2 (mm) |
|---------------------|--------|---------|--------|---------|--------|---------|---------|---------|
| SA3-043-0.75K/1.5KF | 130.0  | 116.0   | 250.0  | 236.0   | 170.0  | 51.3    | 6.2     | 6.2     |
| SA3-043-1.5K/2.2KF  |        |         |        |         |        |         |         |         |
| SA3-043-2.2K/3.7KF  |        |         |        |         |        |         |         |         |
| SA3-043-3.7K/5.5KF  |        |         |        |         |        |         |         |         |
| SA3-043-5.5K/7.5KF  |        |         |        |         |        |         |         |         |
| SA3-023-0.75K/1.5KF |        |         |        |         |        |         |         |         |
| SA3-023-1.5K/2.2KF  |        |         |        |         |        |         |         |         |
| SA3-023-2.2K/3.7KF  |        |         |        |         |        |         |         |         |
| SA3-023-3.7K/5.5KF  |        |         |        |         |        |         |         |         |

Frame B

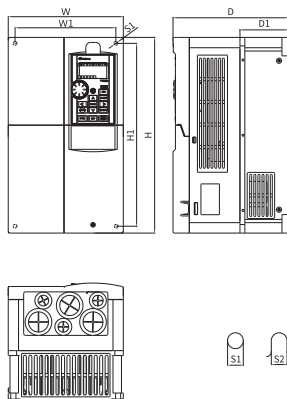

Frame B

| Model type         | W (mm) | W1 (mm) | H (mm) | H1 (mm) | D (mm) | D1 (mm) | S1 (mm) | S2 (mm) |
|--------------------|--------|---------|--------|---------|--------|---------|---------|---------|
| SA3-043-7.5K/11KF  | 190.0  | 173.0   | 320.0  | 303.0   | 190.0  | 80.5    | 8.5     | 8.5     |
| SA3-043-11K/15KF   |        |         |        |         |        |         |         |         |
| SA3-043-15K/18.5KF |        |         |        |         |        |         |         |         |
| SA3-023-5.5K/7.5KF |        |         |        |         |        |         |         |         |
| SA3-023-7.5K/11KF  |        |         |        |         |        |         |         |         |
| SA3-023-11K/15KF   |        |         |        |         |        |         |         |         |

Frame C

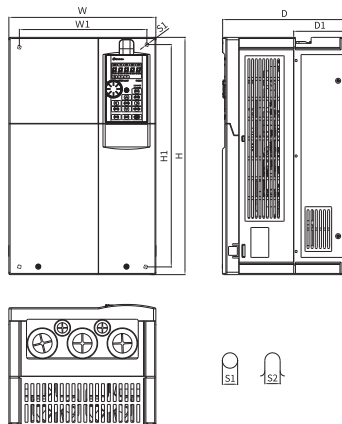

Frame C

| Model type         | W (mm) | W1 (mm) | H (mm) | H1 (mm) | D (mm) | D1 (mm) | S1 (mm) | S2 (mm) |
|--------------------|--------|---------|--------|---------|--------|---------|---------|---------|
| SA3-043-18.5K/22KF | 250.0  | 231.0   | 400.0  | 381.0   | 210.0  | 89.5    | 8.5     | 8.5     |
| SA3-043-22K/30KF   |        |         |        |         |        |         |         |         |
| SA3-043-30K/37KF   |        |         |        |         |        |         |         |         |
| SA3-023-15K/18.5KF |        |         |        |         |        |         |         |         |
| SA3-023-18.5K/22KF |        |         |        |         |        |         |         |         |

### Dimensions

Unit : mm

Frame D

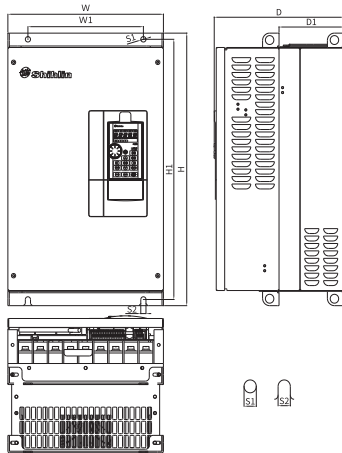

Frame D

| Model type       | W (mm) | W1 (mm) | H (mm) | H1 (mm) | D (mm) | D1 (mm) | S1 (mm) | S2 (mm) |
|------------------|--------|---------|--------|---------|--------|---------|---------|---------|
| SA3-043-37K/45KF | 330.0  | 245.0   | 550.0  | 525.0   | 275.0  | 137.5   | 11.0    | 11.0    |
| SA3-043-45K/55KF |        |         |        |         |        |         |         |         |
| SA3-043-55K/75KF |        |         |        |         |        |         |         |         |
| SA3-043-75K/90KF |        |         |        |         |        |         |         |         |
| SA3-023-22K/30KF |        |         |        |         |        |         |         |         |
| SA3-023-30K/37KF |        |         |        |         |        |         |         |         |
| SA3-023-37K/45KF |        |         |        |         |        |         |         |         |

Frame E

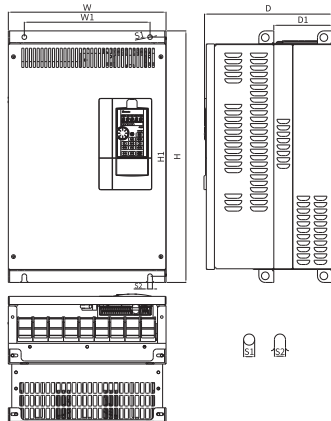

Frame E

| Model type         | W (mm) | W1 (mm) | H (mm) | H1 (mm) | D (mm) | D1 (mm) | S1 (mm) | S2 (mm) |
|--------------------|--------|---------|--------|---------|--------|---------|---------|---------|
| SA3-043-90K/110KF  | 370.0  | 295.0   | 589.0  | 560.0   | 300.0  | 137.5   | 11.0    | 11.0    |
| SA3-043-110K/132KF |        |         |        |         |        |         |         |         |
| SA3-023-45K/55KF   |        |         |        |         |        |         |         |         |
| SA3-023-55K/75KF   |        |         |        |         |        |         |         |         |

Frame F

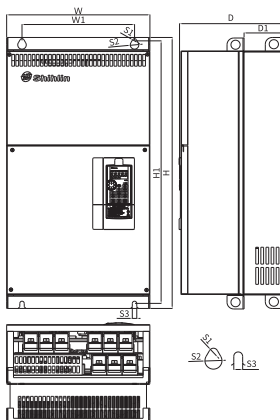

Frame F

| Model type         | W (mm) | W1 (mm) | H (mm) | H1 (mm) | D (mm) | D1 (mm) | S1 (mm) | S2 (mm) | S3 (mm) |
|--------------------|--------|---------|--------|---------|--------|---------|---------|---------|---------|
| SA3-043-132K/160KF | 420.0  | 340.0   | 800.0  | 770.0   | 300.0  | 145.5   | 13.0    | 25.0    | 13.0    |
| SA3-023-75K/90KF   |        |         |        |         |        |         |         |         |         |



SA3

## Dimensions

Unit: mm

### Frame G

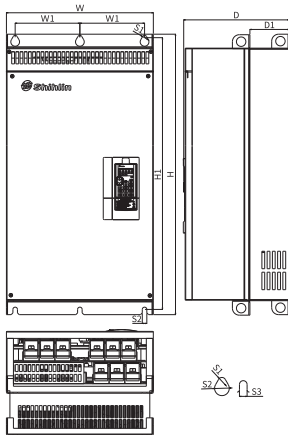

#### Frame G

| Model type         | W (mm) | W1 (mm) | H (mm) | H1 (mm) | D (mm) | D1 (mm) | S1 (mm) | S2 (mm) | S3 (mm) |
|--------------------|--------|---------|--------|---------|--------|---------|---------|---------|---------|
| SA3-043-160K/185KF | 500.0  | 180.0   | 870.0  | 850.0   | 360.0  | 150.0   | 13.0    | 25.0    | 13.0    |
| SA3-043-185K/220KF |        |         |        |         |        |         |         |         |         |
| SA3-043-220K/250KF |        |         |        |         |        |         |         |         |         |
| SA3-043-250K/280KF |        |         |        |         |        |         |         |         |         |
| SA3-023-90K/110KF  |        |         |        |         |        |         |         |         |         |
| SA3-023-110K/132KF |        |         |        |         |        |         |         |         |         |

### Frame H

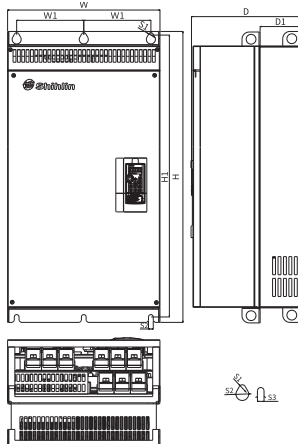

#### Frame H

| Model type         | W (mm) | W1 (mm) | H (mm) | H1 (mm) | D (mm) | D1 (mm) | S1 (mm) | S2 (mm) | S3 (mm) |
|--------------------|--------|---------|--------|---------|--------|---------|---------|---------|---------|
| SA3-043-280K/315KF | 600.0  | 230.0   | 1000.0 | 980.0   | 400.0  | 181.5   | 13.0    | 25.0    | 13.0    |
| SA3-043-315K/355KF |        |         |        |         |        |         |         |         |         |

# SF3 series

Communication  
Vector Control Inverter

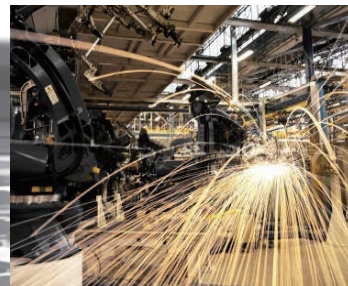

## Product Range

| Model |         | kW (HP)      | 3.7 (5) | 5.5 (7.5)  | 7.5 (10) | 11 (15) | 15 (20) | 18.5 (25) | 22 (30) | 30 (40) | 37 (50) | 45 (60) | 55 (75) | 75 (100) | 90 (120) | 110 (150) | 132 (175) | 160 (215) | 185 (250) | 220 (300) | 250 (335) | 280 (375) | 315 (420) | 355 (475) |
|-------|---------|--------------|---------|--|----------|---------|---------|-----------|---------|---------|---------|---------|---------|----------|----------|-----------|-----------|-----------|-----------|-----------|-----------|-----------|-----------|-----------|
| SF3   | SF3-043 | 3 phase 440V | 150%60s | [Diagram showing connections for various models] |          |         |         |           |         |         |         |         |         |          |          |           |           |           |           |           |           |           |           |           |
|       |         |              | 200%3s  |  |          |         |         |           |         |         |         |         |         |          |          |           |           |           |           |           |           |           |           |           |
|       |         |              | 120%60s |  |          |         |         |           |         |         |         |         |         |          |          |           |           |           |           |           |           |           |           |           |

## Model Identification

**SF3**      **043**    **5.5K/3.7KG**      **XY**

| Series     | Voltage level          | Capacity             | Version  |
|------------|------------------------|----------------------|--|
| SF3 series | 043 : three phase 440V | ND:5.5kW<br>HD:3.7kW | None : General model<br>-xy : Customized or specialized or region difference |

## Product Features

### Multi-Pump Control

- Multi-Pump Control (with EB308R), with multiple relays to support pump control. Controlling maximum of 7 pumps at the same time for 1 inverter.

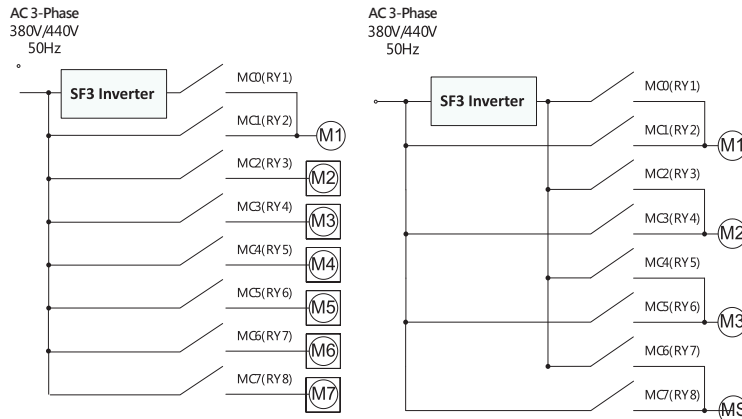

### PC Communication Software

- This provides remote control of multiple inverters for parameters setup, copy and monitoring.

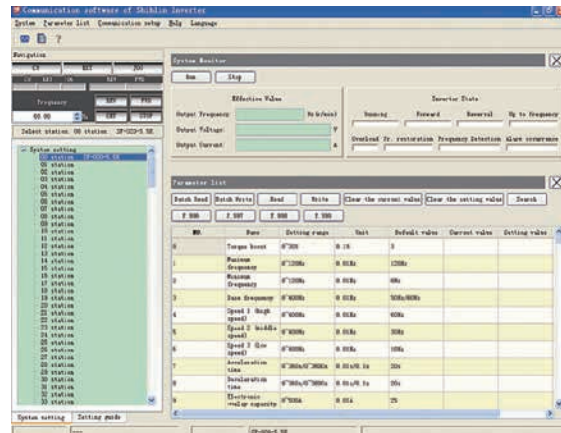

# Product

### 1. Isolated Air Channel

- Ventilation (air flow path) is isolated from the surface of thermal dissipation units and electrical parts. Dust will not be able to infiltrate the interior of the inverter through the fans.

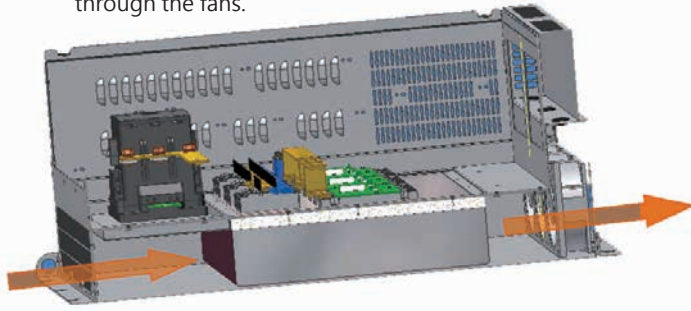

Note: Even though the cooling duct is complete isolated, but if the inverter is installed at the environment where lots of dust or oil gas with out protection, the dust will still pass into inverter.

### 2. Enhanced PCB Coating

- Protect drive and ensure its operation safety and stability.
- Compliance with international standards IEC 60721-3-3 class 3C2.



- Moisture proof
- Corrosion proof
- Dust proof

### 3. Terminal Block for Quick Wiring

- Standard RJ45 internet connection with DA+, DB- Euroblock, easy connection for multi-machine communication.
- Support maximum 100kHz pulse input(HDI) and output(HDI) signal.

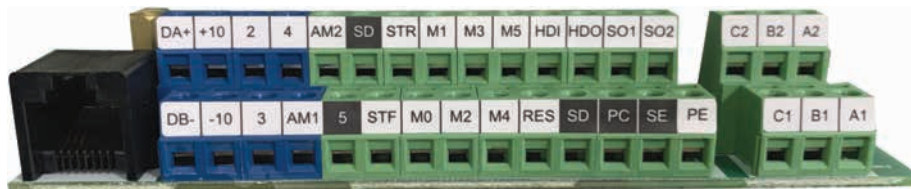

Quick switch for application needs

|        |        |        |        |         |        |
|--------|--------|--------|--------|---------|--------|
| 0-10V  | 4-20mA | 0-10V  | 0-10V  | DEFAULT | SINK   |
| 4-20mA | 0-10V  | 0-20mA | 0-20mA | ↑       | ↓      |
| SW1    | SW2    | SW3    | SW4    | SW5     | SOURCE |





SF3

# Features



## 4. LCD Operation Interface

- Support 2 display styles.
- Able to simultaneously display 6 sets of operational data.
- Calendar support.
- Offer both English and Chinese language interfaces.
- Capable of storing 3 sets of parameters.
- Support shuttle settings.



English display interface

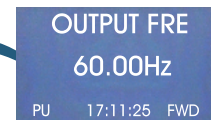

Chinese display interface

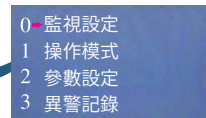

## 6. Built-in RFI Filter

- Reduce electromagnetic interference.

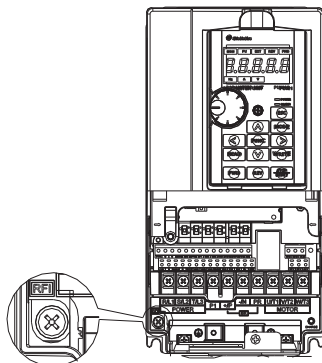

## 5. Through-the-Wall Installation Support Provided for the Entire Series

- Improve heat dissipation, reduce heat generation within the cabinet, and improve protection for the cabinet contents.

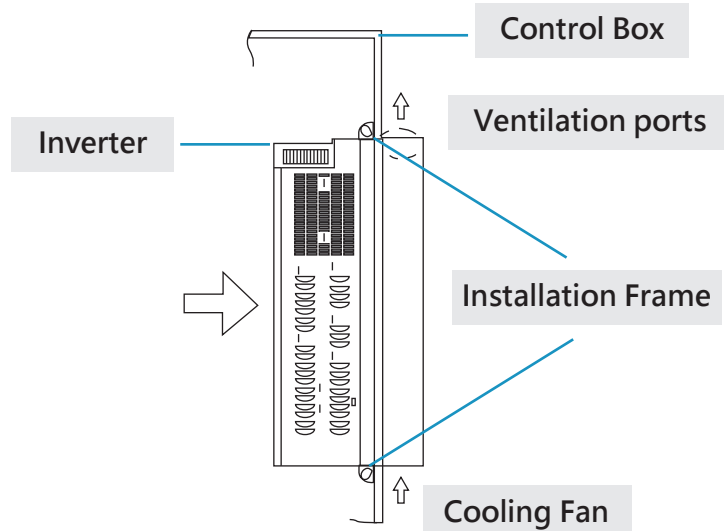

### Electrical Specifications

#### 440V three-phase

| Frame                   |  | A                              |  | B      |       |         | C       |       |         | D     |       |       |       |     |
|-------------------------|--|--------------------------------|--|--------|-------|---------|---------|-------|---------|-------|-------|-------|-------|-----|
| Model SF3-043- □ K □ KG |  | 5.5/3.7                        | 7.5 /5.5                                       | 11/7.5 | 15/11 | 18.5/15 | 22/18.5 | 30/22 | 37/30   | 45/37 | 55/45 | 75/55 | 90/75 |     |
| Output                  | HD   | Rated output capacity (kVA)    | 10   | 14     | 18    | 25      | 29      | 34    | 46      | 56    | 69    | 84    | 114   | 137 |
|                         |  | Rated output current (A)       | 13   | 18     | 24    | 32      | 38      | 45    | 60      | 73    | 91    | 110   | 150   | 180 |
|                         |  | Applicable motor capacity (HP) | 7.5  | 10     | 15    | 20      | 25      | 30    | 40      | 50    | 60    | 75    | 100   | 120 |
|                         |  | Applicable motor capacity(kW)  | 5.5  | 7.5    | 11    | 15      | 18.5    | 22    | 30      | 37    | 45    | 55    | 75    | 90  |
|                         |  | Overload current rating        | 120% 60 seconds (inverse time characteristics) |        |       |         |         |       |         |       |       |       |       |     |
|                         |  | Carrier frequency (kHz)        | 1~15kHz  |        |       |         |         |       | 1~10kHz |       |       |       |       |     |
|                         | ND   | Rated output capacity (kVA)    | 6.9  | 10     | 14    | 18      | 25      | 29    | 34      | 46    | 56    | 69    | 84    | 114 |
|                         |  | Rated output current (A)       | 9  | 13     | 18    | 24      | 32      | 38    | 45      | 60    | 73    | 91    | 110   | 150 |
|                         |  | Applicable motor capacity (HP) | 5  | 7.5    | 10    | 15      | 20      | 25    | 30      | 40    | 50    | 60    | 75    | 100 |
|                         |  | Applicable motor capacity (kW) | 3.7  | 5.5    | 7.5   | 11      | 15      | 18.5  | 22      | 30    | 37    | 45    | 55    | 75  |
|                         |  | Overload current rating        | 150% 60 seconds (inverse time characteristics) |        |       |         |         |       |         |       |       |       |       |     |
|                         |  | Carrier frequency (kHz)        | 1~15kHz  |        |       |         |         |       |         |       |       |       |       |     |
| Maximum output voltage  |  | Three-phase 380-480V           |  |        |       |         |         |       |         |       |       |       |       |     |
| Power supply            | Rated power voltage                            |                                | Three-phase 380-480V 50Hz/60Hz                 |        |       |         |         |       |         |       |       |       |       |     |
|                         | Allowable fluctuating range of power voltage   |                                | Three-phase 342-528V 50Hz/60Hz                 |        |       |         |         |       |         |       |       |       |       |     |
|                         | Allowable fluctuating range of power frequency |                                | ±5%  |        |       |         |         |       |         |       |       |       |       |     |
|                         | Power capacity (kVA)                           |                                | 10.4   | 11.5   | 16    | 20      | 27      | 32    | 41      | 52    | 65    | 79    | 100   | 110 |
| Cooling method          |  | Forced air cooling             |  |        |       |         |         |       |         |       |       |       |       |     |
| Weight(kg)              |  | 3                              | 3  | 6      | 6     | 6       | 10      | 10    | 10      | 11    | 25    | 26    | 30    |     |

| Frame                   |  | E                              |  | F         |           | G         |           |           | H         |           |     |  |
|-------------------------|--|--------------------------------|--|-----------|-----------|-----------|-----------|-----------|-----------|-----------|-----|--|
| Model SF3-043- □ K □ KG |  | 110 / 90                       | 132 / 110                                      | 160 / 132 | 185 / 160 | 220 / 185 | 250 / 220 | 280 / 250 | 315 / 280 | 355 / 315 |     |  |
| Output                  | HD   | Rated output capacity (kVA)    | 168  | 198       | 236       | 295       | 367       | 402       | 438       | 491       | 544 |  |
|                         |  | Rated output current (A)       | 220  | 260       | 310       | 340       | 425       | 480       | 530       | 620       | 683 |  |
|                         |  | Applicable motor capacity (HP) | 150  | 175       | 215       | 250       | 300       | 355       | 375       | 420       | 475 |  |
|                         |  | Applicable motor capacity(kW)  | 110  | 132       | 160       | 185       | 220       | 250       | 280       | 315       | 355 |  |
|                         |  | Overload current rating        | 120% 60 seconds (inverse time characteristics) |           |           |           |           |           |           |           |     |  |
|                         |  | Carrier frequency (kHz)        | 1~9kHz   |           |           |           |           |           |           |           |     |  |
|                         | ND   | Rated output capacity (kVA)    | 137  | 168       | 198       | 236       | 295       | 367       | 402       | 438       | 491 |  |
|                         |  | Rated output current (A)       | 180  | 220       | 260       | 310       | 340       | 425       | 480       | 530       | 620 |  |
|                         |  | Applicable motor capacity (HP) | 120  | 150       | 175       | 215       | 250       | 300       | 335       | 375       | 420 |  |
|                         |  | Applicable motor capacity (kW) | 90   | 110       | 132       | 160       | 185       | 220       | 250       | 280       | 315 |  |
|                         |  | Overload current rating        | 150% 60 seconds (inverse time characteristics) |           |           |           |           |           |           |           |     |  |
|                         |  | Carrier frequency (kHz)        | 1~10kHz  |           |           |           |           |           |           |           |     |  |
| Maximum output voltage  |  | Three-phase 380-480V           |  |           |           |           |           |           |           |           |     |  |
| Power supply            | Rated power voltage                            |                                | Three-phase 380-480V 50Hz/60Hz                 |           |           |           |           |           |           |           |     |  |
|                         | Allowable fluctuating range of power voltage   |                                | Three-phase 342-528V 50Hz/60Hz                 |           |           |           |           |           |           |           |     |  |
|                         | Allowable fluctuating range of power frequency |                                | ±5%  |           |           |           |           |           |           |           |     |  |
|                         | Power capacity (kVA)                           |                                | 137  | 165       | 198       | 247       | 295       | 367       | 402       | 438       | 491 |  |
| Cooling method          |  | Forced air cooling             |  |           |           |           |           |           |           |           |     |  |
| Weight(kg)              |  | 38                             | 39   | 56        | 56        | 93        | 93        | 93        | 120       | 120       |     |  |

**Note:**

The test conditions of rated output current, rated output capacity and inverter power consumption are: carrier frequency (P.72) is default setting; inverter output voltage is at 440V; output frequency is at 60Hz, and surrounding temperature is 40°C.



SF3

## Common Specifications

|   |                                       |  |
|---|---------------------------------------|--|
| Control method                                    |                                       | SVPWM, V/F, general flux vector control, sensorless vector control (SVC).  |
| Output frequency range                            |                                       | 0~599Hz  |
| Frequency setting resolution                      | Digital setting                       | The resolution is 0.01 Hz when the frequency is set within 100 Hz;<br>The resolution is 0.1 Hz when the frequency is set at above 100 Hz.  |
|   | Analog setting                        | 11bit, DC 0~+5V or 4~20mA signal setting; 12bit, DC 0~+10V signal setting  |
| Output frequency accuracy                         | Digital setting                       | Maximum target frequency±0.01%.  |
|   | Analog setting                        | Maximum target frequency±0.1%.   |
| Speed control range                               |                                       | IM: When SVC, 1:200 , PM: When SVC,1:20.   |
| Start torque                                      |                                       | 150% 0.5Hz (SVC)。  |
| V/F characteristics                               |                                       | Constant torque curve, variable torque curve, five-point curve, VF separation.   |
| Acceleration / deceleration curve characteristics |                                       | Linear acceleration /deceleration curve, S pattern acceleration / deceleration curve1 & 2 & 3.   |
| Drive motor                                       |                                       | Induction motor(IM), permanent magnet synchronous motor (SPM, IPM).  |
| Current stall protection                          |                                       | The stall protection level can be set to 0~200%(06-01(P.22)). The default value is 120%(HD) /150%(ND).   |
| Target frequency setting                          |                                       | TKeypad setting, DC 0~5V/10V signal, DC -10~+10V signal, DC 4~20 mA signal, multi- speed stage level setting, communication setting, HDI setting.  |
| PID control                                       |                                       | Please refer to SF3 user manual.   |
| Built-in simple PLC                               |                                       | Supports 21 basic instructions and 14 application instructions, including PC editing software please refer to manual at build-in PLC chapter.  |
| Operation panel                                   | Operation monitoring                  | Output frequency, output current, output voltage, PN voltage, output torque, electronic thermal accumulation rate, temperature rising accumulation rate, output power, analog value input signal, external terminal status... ; at most 12 groups of alarm records, the last group of alarm message is recorded.   |
|   | LED indicator (8)                     | Forward rotation indicator, reverse rotation indicator, frequency monitoring indicator, voltage monitoring indicator, current monitoring indicator, mode switch indicator, PU control indicator and external terminal control indicator.   |
| Communication                                     |                                       | RS-485 communication, can select Shihlin/Modbus communication protocol, communication speed up to 115200bps, CANOpen protocol (with optional CP301 expanded board).  |
| Protection mechanism / alarm function             |                                       | Output short circuit protection, over-current protection, over-voltage protection, under-voltage protection, motor over-heat protection (06-00(P.9)), IGBT module over-heat protection, communication abnormality protection, PTC temperature protection etc. capacitor overheat, input and output phase loss, to-earth(ground) current leakage protection, circuit error detection... |
| Environment                                       | Ambient temperature                   | -10 ~ +40°C (non-freezing)   |
|   | Ambient humidity                      | Below 90%Rh (non-condensing).  |
|   | Storage temperature                   | -20 ~ +65°C。   |
|   | Surrounding environment               | Indoor, no corrosive gas, no flammable gas, no flammable powder.   |
|   | Altitude                              | Altitude below 2000 m, but when altitude is above 1000 m, 2% of the rated current needs to be decreased per 1000 rising  |
|   | Vibration                             | Vibration below 5.9m/s <sup>2</sup> (0.6G).  |
|   | Grade of protection                   | IP20 for frames A, B and C, IP00 for frame D and above (IP20 accessories shall be optional)  |
|   | The degree of environmental pollution | 2  |
| Class of protection                               |                                       | Class I  |
| International certification                       |                                       | CE   |

### Wiring Diagram

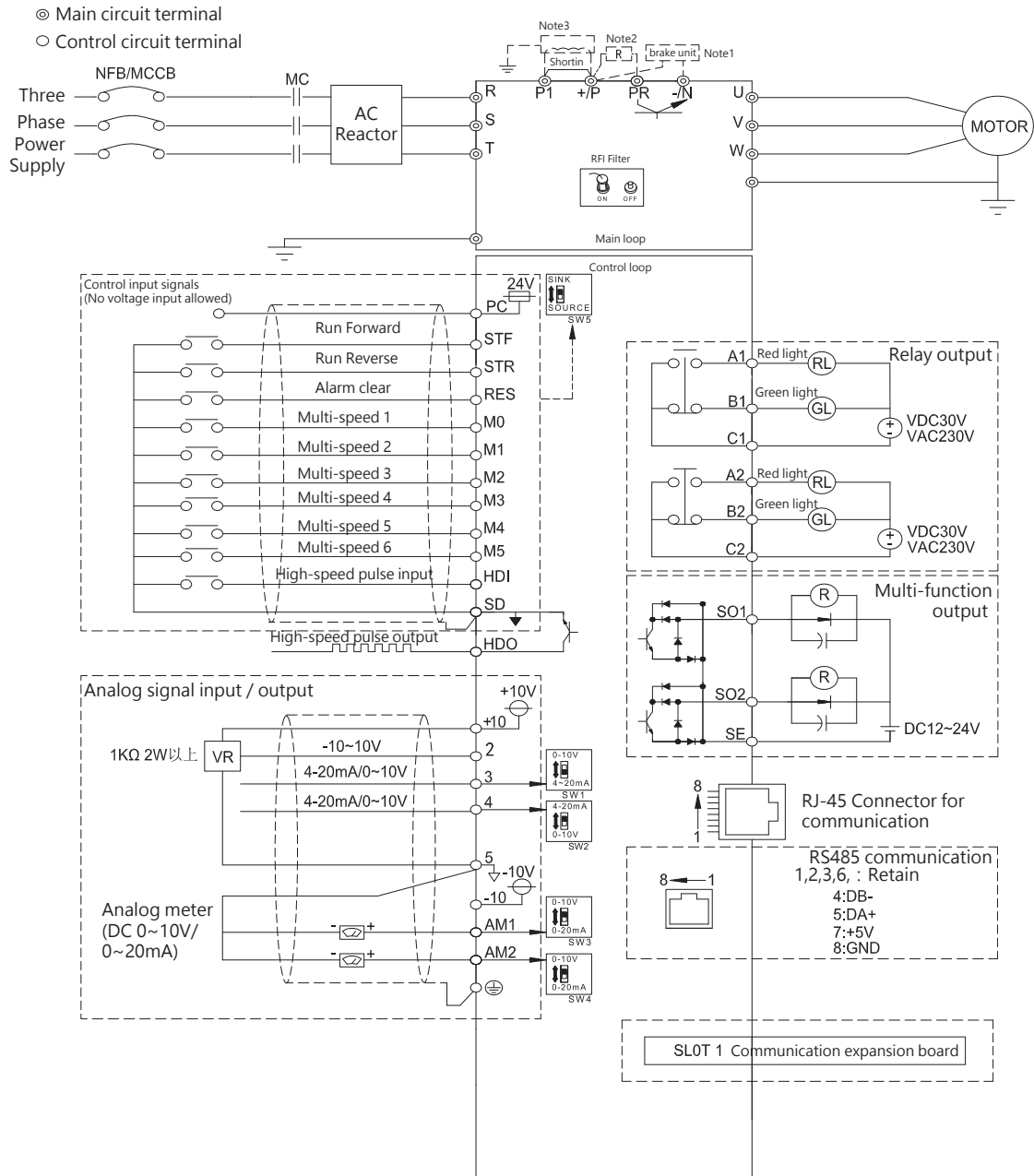

#### NOTE

1. Braking resistor wiring method between +P/PR is only for frame A, B and C. For frame D, E, G and H, the braking resistor is connect between (+P)/(-N).
2. DC reactor can be added between +P and P1. When DC reactor is not in used, short those terminals.
3. When adding DC reactor, the jumper between +P and P1 must be removed.



SF3

## Dimensions

Unit: mm

### Frame A

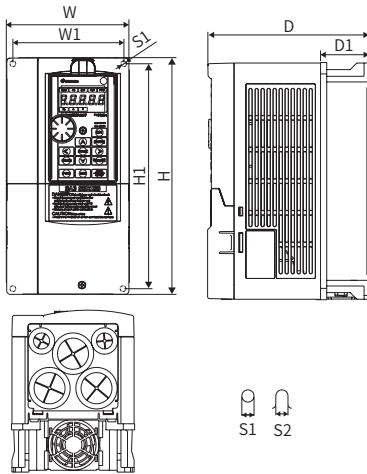

#### Frame A

| Model type         | W (mm) | W1 (mm) | H (mm) | H1 (mm) | D (mm) | D1 (mm) | S1 (mm) | S2 (mm) |
|--------------------|--------|---------|--------|---------|--------|---------|---------|---------|
| SF3-043-5.5K/3.7KG | 130.0  | 116.0   | 250.0  | 236.0   | 170.0  | 51.3    | 6.2     | 6.2     |
| SF3-043-7.5K/5.5KG |        |         | 236.0  | 250.0   |        |         |         |         |

### Frame B

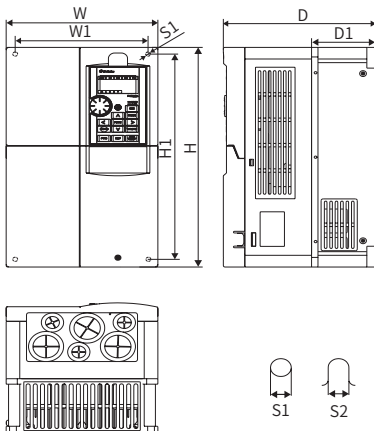

#### Frame B

| Model type         | W (mm) | W1 (mm) | H (mm) | H1 (mm) | D (mm) | D1 (mm) | S1 (mm) | S2 (mm) |
|--------------------|--------|---------|--------|---------|--------|---------|---------|---------|
| SF3-043-11K/7.5KG  | 190.0  | 173.0   | 320.0  | 303.0   | 190.0  | 80.5    | 8.5     | 8.5     |
| SF3-043-15K/11KG   |        |         | 303.0  | 320.0   |        |         |         |         |
| SF3-043-18.5K/15KG |        |         | 320.0  | 303.0   |        |         |         |         |

### Frame C

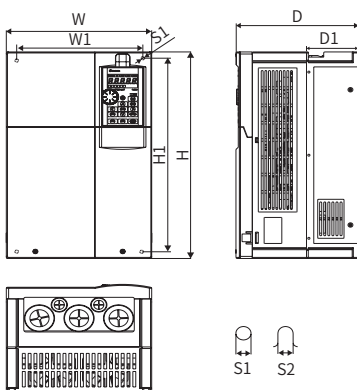

#### Frame C

| Model type         | W (mm) | W1 (mm) | H (mm) | H1 (mm) | D (mm) | D1 (mm) | S1 (mm) | S2 (mm) |
|--------------------|--------|---------|--------|---------|--------|---------|---------|---------|
| SF3-043-22K/18.5KG | 250.0  | 231.0   | 400.0  | 381.0   | 210.0  | 89.5    | 8.5     | 8.5     |
| SF3-043-30K/22KG   |        |         | 381.0  | 400.0   |        |         |         |         |
| SF3-043-37K/30KG   |        |         | 400.0  | 381.0   |        |         |         |         |
| SF3-043-45K/37KG   |        |         | 381.0  | 400.0   |        |         |         |         |

### Dimensions

Unit: mm

Frame D

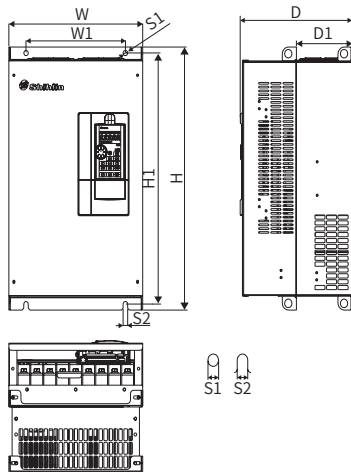

Frame D

| Model type       | W (mm) | W1 (mm) | H (mm) | H1 (mm) | D (mm) | D1 (mm) | S1 (mm) | S2 (mm) |
|------------------|--------|---------|--------|---------|--------|---------|---------|---------|
| SF3-043-55K/45KG | 330.0  | 245.0   | 550.0  | 525.0   | 275.0  | 137.5   | 11.0    | 11.0    |
| SF3-043-75K/55KG |        |         |        |         |        |         |         |         |
| SF3-043-90K/75KG |        |         |        |         |        |         |         |         |

Frame E

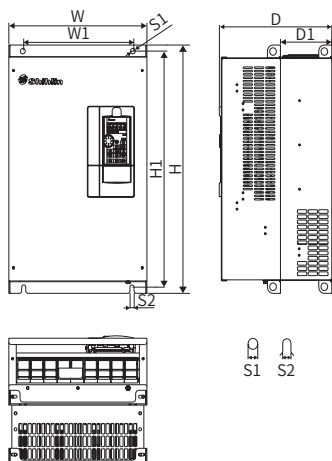

Frame E

| Model type         | W (mm) | W1 (mm) | H (mm) | H1 (mm) | D (mm) | D1 (mm) | S1 (mm) | S2 (mm) |
|--------------------|--------|---------|--------|---------|--------|---------|---------|---------|
| SF3-043-110K/90KG  | 370.0  | 295.0   | 589.0  | 560.0   | 300.0  | 137.5   | 11.0    | 11.0    |
| SF3-043-132K/110KG |        |         |        |         |        |         |         |         |

Frame F

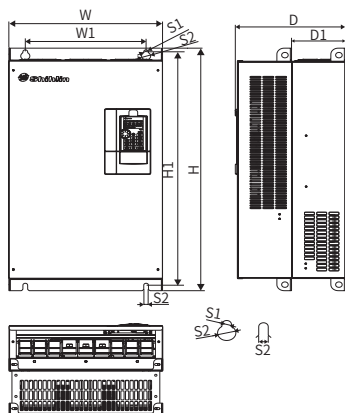

Frame F

| Model type         | W (mm) | W1 (mm) | H (mm) | H1 (mm) | D (mm) | D1 (mm) | S1 (mm) | S2 (mm) | S3 (mm) |
|--------------------|--------|---------|--------|---------|--------|---------|---------|---------|---------|
| SF3-043-160K/132KG | 420.0  | 330.0   | 800.0  | 770.0   | 300.0  | 145.5   | 13.0    | 25.0    | 13.0    |
| SF3-043-185K/160KG |        |         |        |         |        |         |         |         |         |



SF3

## Dimensions

Unit: mm

### Frame G

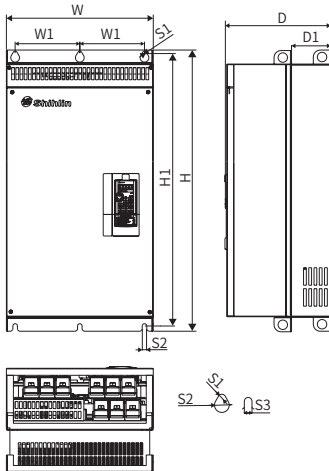

### Frame G

| Model type         | W (mm) | W1 (mm) | H (mm) | H1 (mm) | D (mm) | D1 (mm) | S1 (mm) | S2 (mm) | S3 (mm) |
|--------------------|--------|---------|--------|---------|--------|---------|---------|---------|---------|
| SF3-043-220K/185KG | 500.0  | 180.0   | 870.0  | 850.0   | 360.0  | 150.0   | 13.0    | 25.0    | 13.0    |
| SF3-043-250K/220KG |        |         |        |         |        |         |         |         |         |
| SF3-043-280K/250KG |        |         |        |         |        |         |         |         |         |

### Frame H

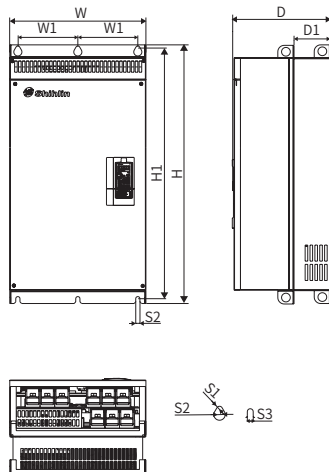

### Frame H

| Model type         | W (mm) | W1 (mm) | H (mm) | H1 (mm) | D (mm) | D1 (mm) | S1 (mm) | S2 (mm) | S3 (mm) |
|--------------------|--------|---------|--------|---------|--------|---------|---------|---------|---------|
| SF3-043-315K/280KG | 600.0  | 230.0   | 1000.0 | 980.0   | 400.0  | 181.5   | 13.0    | 25.0    | 13.0    |
| SF3-043-355K/315KG |        |         |        |         |        |         |         |         |         |

### Keypad Dimensions

PU301、PU301C

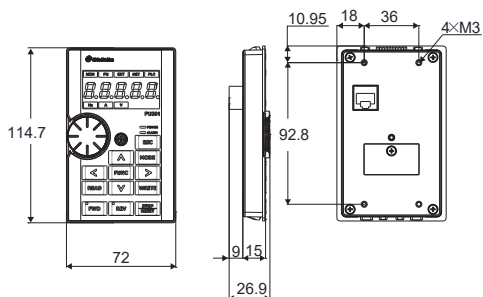

### Flat Spring Installation

SMK301 (PU301, PU301C Mounting kit)

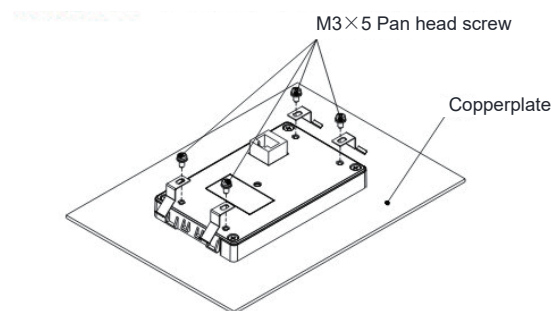

# SS2 series

General low kW  
Vector Control Inverter

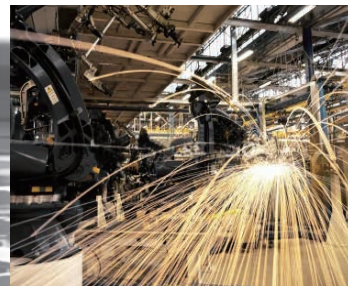

## Product Range

| Model |     | kW<br>(HP)   | 0.4<br>(0.5) | 0.75<br>(1) | 1.5<br>(2) | 2.2<br>(3) | 3.7<br>(5) | 5.5<br>(7.5) |  |
|-------|-----|--------------|--------------|-------------|------------|------------|------------|--------------|--|
| SS2   | 021 | 1 phase 220V | ■            |             |            | ■          |            |              |  |
|       | 023 | 3 phase 220V | ■            |             |            |            |            | ■            |  |
|       | 043 | 3 phase 440V | ■            |             |            |            |            |              |  |

## Main Features

- \* Built-in shuttle knob to adjust output frequency and set parameters easily
- \* Built-in RS485 communication interface
- \* Support MODBUS and Shihlin communication protocol
- \* Built-in proportion linkage control function to support multi inverters connection
- \* Maximum 650Hz frequency output
- \* Support DIN rail mount
- \* The resolution of frequency setting: digital 0.01Hz ; analog 1/1000
- \* The accuracy of output frequency: 0.01%
- \* Multi-function input/output terminals
- \* Support 2 analog setting types: 0-10V and 4-20mA

## Model Identification

| Series     | Voltage level   | Capacity | Version  |
|------------|---|----------|--|
| SS2 series | 043 : three phase 440V<br>023 : three phase 220V<br>021 : single phase 220V | 0.75kW   | None : General model<br>-xy : Customized or specialized or region difference |

**SS2**

### Product Features

#### General Flux Vector Control Technique

- General flux vector control technique.
- A 32-bit RISC CPU for high-speed computation.
- Starting torque, 150%3Hz.

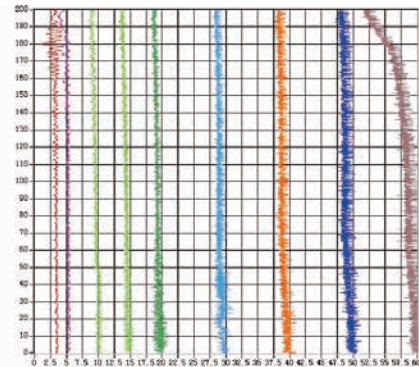

- Speed accuracy is within 1% (0%~100% loading changes).

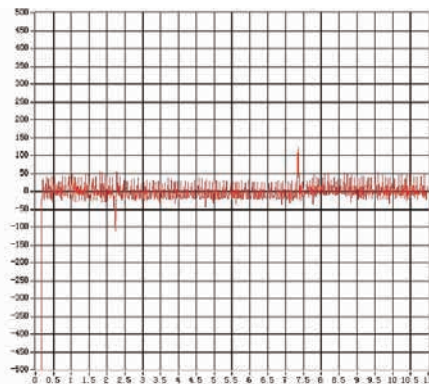

- Motor parameter auto-tuning function.
- Stalling protection level reaches to 250%.

#### High Performance And Function

- The maximum output frequency up to 650Hz.
- Soft-PWM functions for eliminating motor noises and preventing the temperature of IGBT module too high.
- Built-in energy-saving control function, inverter will control the output voltage automatically in order to reduce the output power losses when inverter is running.
- Cooling fan operation method is selectable.

#### Built-in Proportion Linkage Function

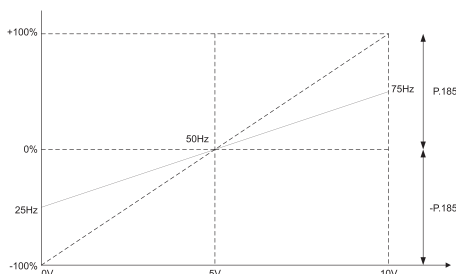

#### PID Feedback Control Function

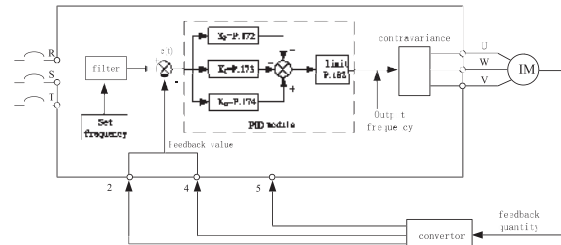

#### Triangular Wave Function (traverse)

- This is suitable for operations that need traversing and winding movements such as textile operations.

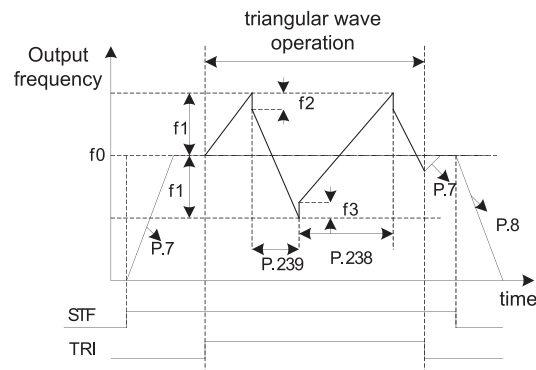

- f0 : Setting value of frequency
- f1 : Generated amplitude for setting frequency ( $f_0 \times P.235$ )
- f2 : Compensation from acceleration to deceleration ( $f_1 \times P.236$ )
- f3 : Compensation from deceleration to acceleration ( $f_1 \times P.237$ )

#### Built-in Frequency And Parameter Setting Knob





SS2

## Product Features

### PWM Control Function

- The operating frequency can be controlled with the PWM signals output from PLC.
- The terminal M2 can be set as PWM signal input.

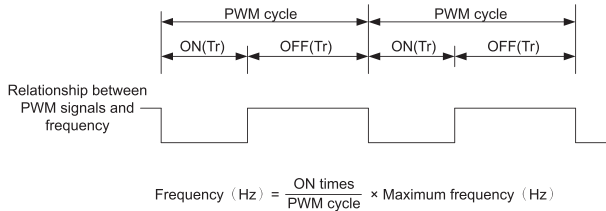

### Programmed Operation Mode With Manual Operation

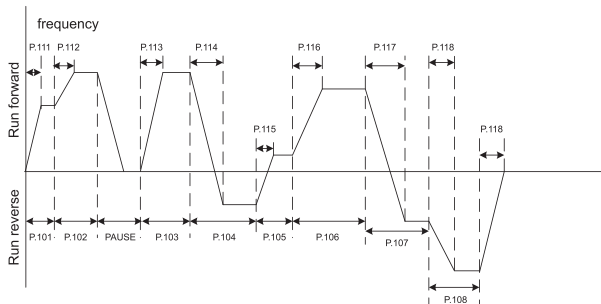

### Equipped With Grid Power Frequency Switching Mechanism

- It provides automatic switch between the grid power and frequency conversion.
- If the motor is running at rated frequency, using grid power frequency has a much better efficiency.

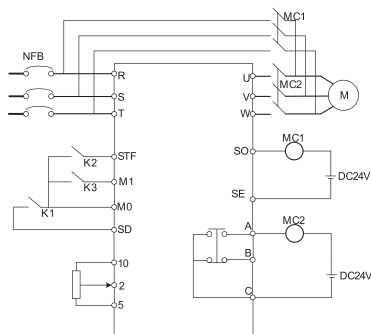

### Easy To Install Design

- Din rail design for multiple inverters side by side installation.



- Built-in standard RJ45 port for RS485 communication.
- Screwless terminal blocks designed



- The cooling fan is removable and easy to clean.



### Electric Specifications

#### 220V Series Single-Phase

| Model SS2-021- □□□ K      |   | 0.4K  | 0.75K              | 1.5K | 2.2K |
|---------------------------|---|---|--------------------|------|------|
| Applicable Motor Capacity | HP                                      | 0.5   | 1                  | 2    | 3    |
|                           | kW                                      | 0.4   | 0.75               | 1.5  | 2.2  |
| Output                    | Rated output capacity kVA (Note)        | 0.95  | 1.5                | 2.5  | 4.2  |
|                           | Rated output current A (Note)           | 2.7   | 4.5                | 8    | 11   |
|                           | Overload current rating                 | 150% 60 seconds; 200% 1 second (inverse time characteristics) |                    |      |      |
|                           | Maximum output voltage                  | 3 Phase 200~240V AC   |                    |      |      |
| Power supply              | Rated power voltage                     | Single phase 200~240V 50Hz/ 60Hz                              |                    |      |      |
|                           | Power voltage permissible fluctuation   | Single phase 170~264V 50Hz / 60Hz                             |                    |      |      |
|                           | Power frequency permissible fluctuation | ±5%   |                    |      |      |
|                           | Power source capacity kVA               | 1.5   | 2.5                | 3.5  | 6.4  |
|                           | Cooling Method                          | Self-cooling  | Forced air cooling |      |      |
| Inverter weight (kg)      |   | 1.2   | 1.2                | 1.6  | 1.7  |

#### 220V Series Three-Phase

| Model SS2-023- □□□ K      |   | 0.4   | 0.75               | 1.5 | 2.2 | 3.7  |
|---------------------------|---|---|--------------------|-----|-----|------|
| Applicable Motor Capacity | HP                                      | 0.5   | 1                  | 2   | 3   | 5    |
|                           | kW                                      | 0.4   | 0.75               | 1.5 | 2.2 | 3.7  |
| Output                    | Rated output capacity kVA (Note)        | 1.2   | 2                  | 3.2 | 4.2 | 6.7  |
|                           | Rated output current A (Note)           | 3   | 5                  | 8   | 11  | 17.5 |
|                           | Overload current rating                 | 150% 60 seconds; 200% 1 second (inverse time characteristics) |                    |     |     |      |
|                           | Maximum output voltage                  | 3 Phase 200~240V AC   |                    |     |     |      |
| Power supply              | Rated power voltage                     | 3 Phase 200~240V 50Hz/60Hz                                    |                    |     |     |      |
|                           | Power voltage permissible fluctuation   | 3 Phase 170~264V 50Hz/60Hz                                    |                    |     |     |      |
|                           | Power frequency permissible fluctuation | ±5%   |                    |     |     |      |
|                           | Power source capacity kVA               | 1.5   | 2.5                | 4.5 | 6.4 | 10   |
|                           | Cooling Method                          | Self-cooling  | Forced air cooling |     |     |      |
| Inverter weight (kg)      |   | 1.1   | 1.2                | 1.2 | 1.6 | 1.7  |

#### 440V Series Three-Phase

| Model SS2-043- □□□ K      |   | 0.4   | 0.75         | 1.5                | 2.2 | 3.7  | 5.5  |
|---------------------------|---|---|--------------|--------------------|-----|------|------|
| Applicable Motor Capacity | HP                                      | 0.5   | 1            | 2                  | 3   | 5    | 7.5  |
|                           | kW                                      | 0.4   | 0.75         | 1.5                | 2.2 | 3.7  | 5.5  |
| Output                    | Rated output capacity kVA (Note)        | 1   | 2            | 3                  | 4.6 | 6.9  | 9.2  |
|                           | Rated output current A (Note)           | 1.5   | 2.6          | 4.2                | 6   | 9    | 12   |
|                           | Overload current rating                 | 150% 60 Seconds; 200% 1 Second (inverse time characteristics) |              |                    |     |      |      |
|                           | Maximum output voltage                  | Three-phase 380~480V  |              |                    |     |      |      |
| Power supply              | Rated power voltage                     | 3 Phase 380~480V 50Hz / 60Hz                                  |              |                    |     |      |      |
|                           | Power voltage permissible fluctuation   | 323~528V 50Hz/60Hz  |              |                    |     |      |      |
|                           | Power frequency permissible fluctuation | ±5%   |              |                    |     |      |      |
|                           | Power source capacity kVA               | 1.5   | 2.5          | 4.5                | 6.9 | 10.4 | 13.8 |
|                           | Cooling Method                          | Self-cooling  | Self-cooling | Forced air cooling |     |      |      |
| Inverter weight (kg)      |   | 1.1   | 1.1          | 1.2                | 1.6 | 1.7  | 1.7  |

**Note:**

The test conditions of rated output current, rated output capacity and inverter power consumption are: the carrier frequency (P.72) is at factory setting value; the inverter output voltage is at 220V/440V; the output frequency is at 60Hz, and the ambient temperature is 50°C.



## Common Specifications

|   |                                 |   |  |
|---|---------------------------------|---|--|
| Control Method                                    |                                 | SVPWM control, V/F control, general flux vector control.  |  |
| Output Frequency Range                            |                                 | 0.1~650Hz (The starting frequency setting range is between 0 and 60Hz).   |  |
| Frequency Resolution                              | Digital setting                 | If the frequency value is set below 100Hz, the resolution will be 0.01Hz.<br>If the frequency value is set above 100Hz, the resolution will be 0.1Hz.   |  |
|   | Analog setting                  | When setting the signal DC 0~5V, the resolution will be 1/500;<br>When setting the signal DC 0~10V or 4~20mA, the resolution will be 1/1000.  |  |
| Output Frequency Accuracy                         | Digital setting                 | Maximum target frequency±0.01%.   |  |
|   | Analog setting                  | Maximum target frequency±0.5%.  |  |
| Voltage / Frequency output Characteristics        |                                 | Base voltage (P.19), base frequency (P.3) can be arbitrarily set.<br>Constant torque model and applicable load model can be selected (P.14).  |  |
| Starting Torque                                   |                                 | 150% 3Hz, 200% 5Hz: when using the general flux vector control.   |  |
| Torque Boost                                      |                                 | The torque boost setting range between 0 and 30% (P.0), auto boost, slip compensation.  |  |
| Acceleration / Deceleration Curve Characteristics |                                 | The resolution (0.01s/0.1s) of acceleration/deceleration time (P.7, P.8) is switched by P.21. The setting range has 0~360s or 0~3600s for selection. And different acceleration/deceleration curve model can be selected by P.29.     |  |
| DC Braking  |                                 | The DC braking action frequency range between 0 and 120Hz (P.10); the DC braking time is 0~60 Seconds (P.11); and the DC braking voltage is 0~30% (P.12).<br>Linear braking and idling braking selection (P.71).                      |  |
| Stall current protection                          |                                 | The stalling protection level can be set between 0 and 250% (P.22).   |  |
| Target Frequency Setting                          |                                 | Operation panel setting, DC 0~5V signal setting, DC 0~10V signal setting, DC 4~20mA signal setting, Multi-speed stage levels setting, communication setting, pulse frequency setting.   |  |
| PID Control                                       |                                 | Please refer to P.170~P.183 in Chapter 5.   |  |
| Multifunction Control Terminals                   |                                 | Motor starting (STF, STR), the second function (RT), '16-speed operation' (RL, RM, RH, REX), external thermal relay (OH), reset (RES), etc. (can be set by the user (P.80~P.84, P.86))  |  |
| Multiple Output Terminals                         | Multi-function output terminals | SO, SE  | P.40 Inverter running (RUN), output frequency detection (FU), Up to output frequency(SU), overload detection (OL), zero current detection (OMD), alarm (ALARM), Section detection (PO1), Periodical detection (PO2), and Pause detection (PO3), Inverter output (BP), Commercial power-supply output (GP). |
|   | Multi-function output relay     | A, B, C   |  |
|   | Analog output                   | AM, 5   |  |
| Operation Panel                                   | Running status monitoring       |   | Output frequency monitoring, output current monitoring, and output voltage monitoring, alarm record  |
|   | HELP mode                       |   | Alarm history monitoring.  |
|   | LED indicator (6)               |   | Run indicator, frequency monitoring indicator, voltage monitoring indicator, current monitoring indicator, mode switching indicator, and PU control indicator.   |
| Communication Function                            |                                 | RS485   | Build-in RS485 communication, RJ-45 connector.   |
| Protection Mechanism / Alarm function             |                                 | Output short circuit protection, Over-current protection, (+P)-(-N) over-voltage protection, under-voltage protection, motor over heat protection (P.9), IGBT module over-heat protection, communication abnormality protection, etc. |  |
| Environmental Condition                           | Ambient temperature             |   | -10 ~ +50C (non-freezing), installation side by side -10~ +40°C.   |
|   | Ambient humidity                |   | Below 90%Rh (non-condensing)   |
|   | Storage temperature             |   | -20 ~ +65°C  |
|   | Surrounding environment         |   | Indoor, no corrosive gas, no flammable gas, no flammable dust  |
|   | Altitude and vibration          |   | Altitude:below 1000 m, Vibration:below 5.9m/s <sup>2</sup> (0.6G).   |
|   | Enclosure Rating                |   | IP20   |
|   | Pollution level                 |   | 2  |
| Class of protection                               |                                 | Class 1   |  |
| Certification                                     |                                 | CE  |  |

### Wiring Diagram

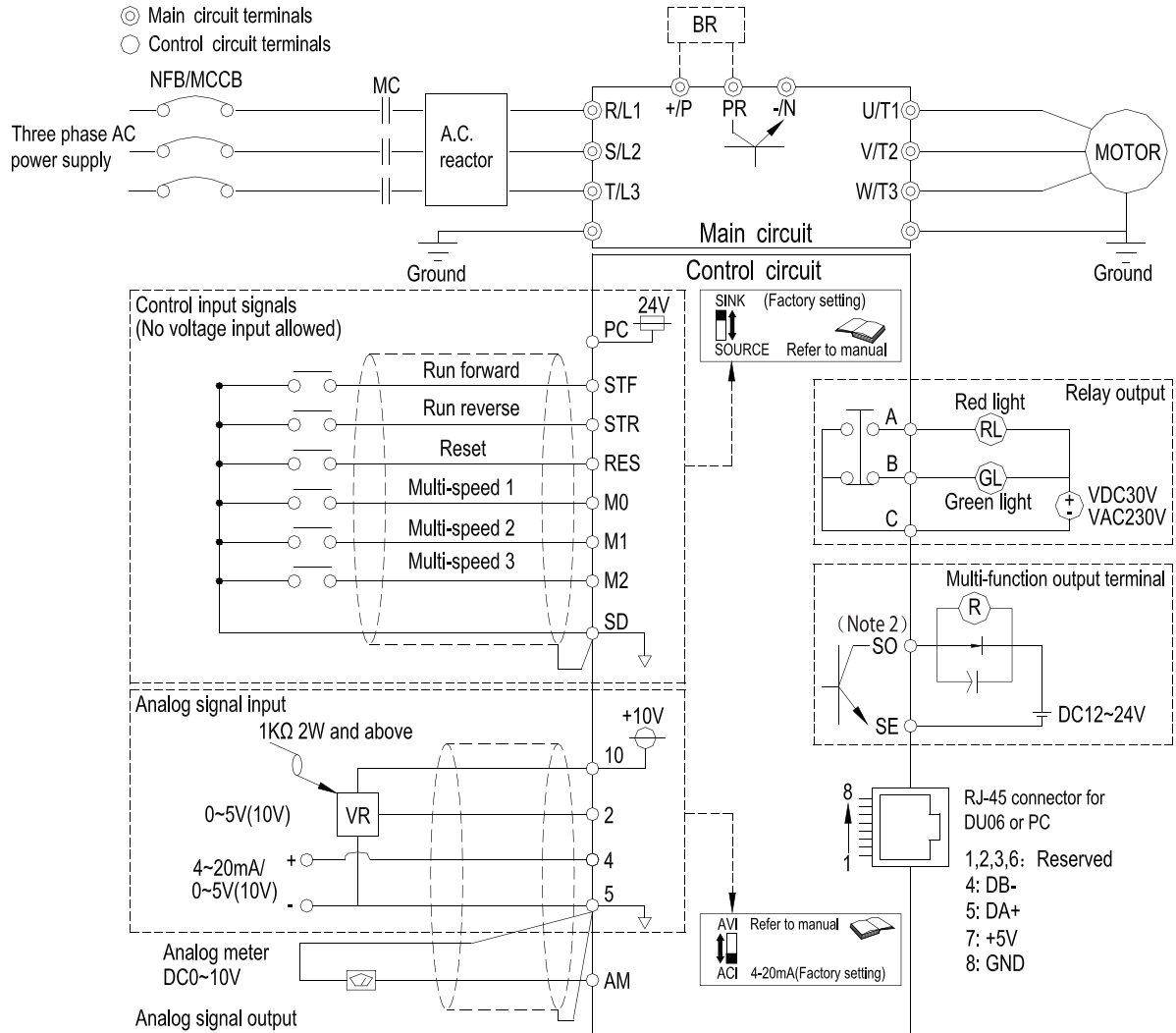

#### NOTE

1. For the usage of the external thermal relay, please refer to P.80~P.84, P.86 in Chapter 5 (OH) on the manual.
2. Make sure not to short circuit the PC and SD.
3. In the above figure, dotted line area, please refer to 3.5.7 on the manual.
4. The SO terminal can select to FM or 10X function, please refer to P.64, P.74.
5. For single-phase series inverters, there is no T/L3 terminal, and the corresponding wiring (dotted line) doesn't need to be connected.



SS2

## Dimensions

### Frame A

Unit: mm

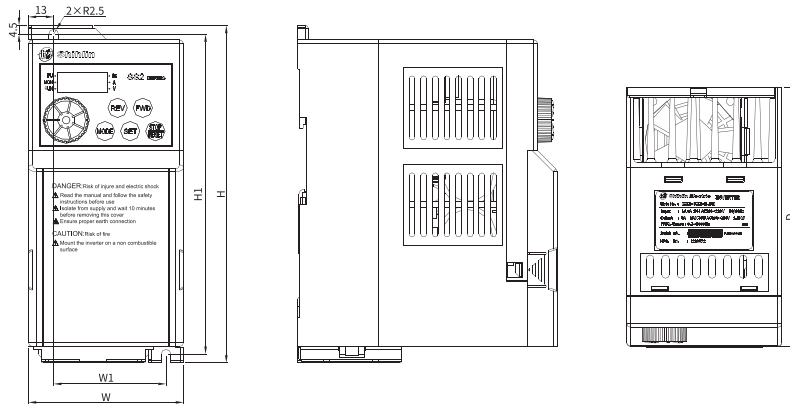

#### Frame A

| Model         | H (mm) | H1 (mm) | W (mm) | W1 (mm) | D (mm) |
|---------------|--------|---------|--------|---------|--------|
| SS2-021-0.4K  | 174    | 165     | 80     | 58      | 134    |
| SS2-021-0.75K |        |         |        |         |        |
| SS2-023-0.4K  |        |         |        |         |        |
| SS2-023-0.75K |        |         |        |         |        |
| SS2-023-1.5K  |        |         |        |         |        |
| SS2-043-0.4K  |        |         |        |         |        |
| SS2-043-0.75K |        |         |        |         |        |
| SS2-043-1.5K  |        |         |        |         |        |

### Frame B

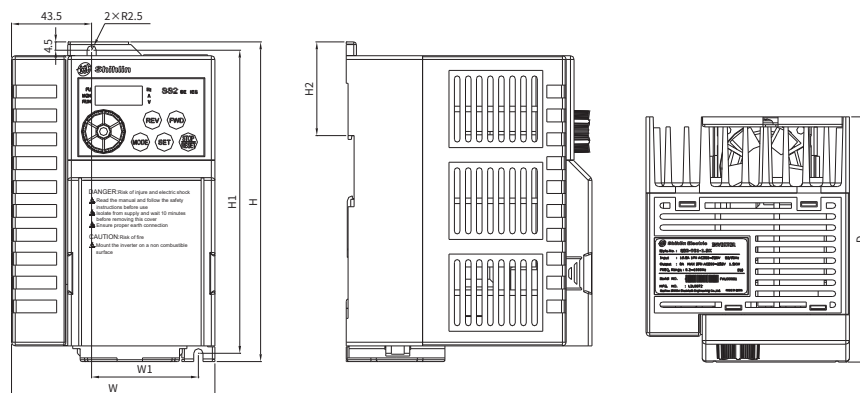

#### Frame B

| Model        | H (mm) | H1 (mm) | W (mm) | W1 (mm) | D (mm) |
|--------------|--------|---------|--------|---------|--------|
| SS2-021-1.5K | 174    | 165     | 110.5  | 58      | 134    |
| SS2-021-2.2K |        |         |        |         |        |
| SS2-023-2.2K |        |         |        |         |        |
| SS2-023-3.7K |        |         |        |         |        |
| SS2-043-2.2K |        |         |        |         |        |
| SS2-043-3.7K |        |         |        |         |        |
| SS2-043-5.5K |        |         |        |         |        |

# Applications

## Applications

Simple



**SC3**  
(0.2~5.5kW)



Mixer Machine



Conveyer Belt

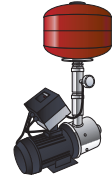

Constant pressure  
Water supply

Normal



**SS2**  
(0.4~5.5kW)

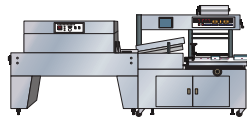

Packing Machine

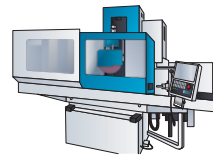

Grinding Machine

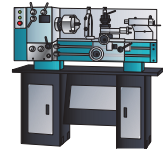

Desktop type lathe

Big  
&  
Simple



**SF3**  
(3.7~355kW)



Wire drawing machine

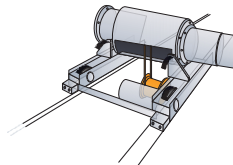

Crane



Air Compressor

High  
Speed  
Spindle



**SE3**  
(0.4~22kW)

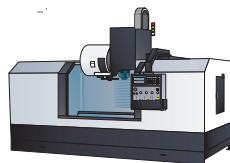

CNC tooling Machine



Polishing Machine

Closed  
Loop or  
Advanced



**SA3**  
(0.75~315kW)



Mechanical Press

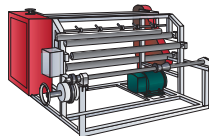

Textile Equipment



Wood cutting

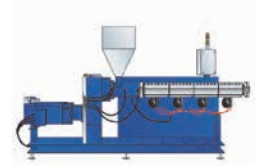

Extrusion Machine

## Optional Equipment - SF3 / SE3 / SA3 Series

### PD302

Profibus communication expansion card



### DN301

DeviceNet communication expansion card



### CP301

CANopen communication expansion card



### EP301

Ethernet communication expansion card



### EB362R

I/O expansion card

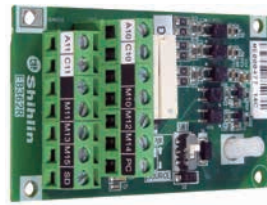

### EB308R

I/O expansion card

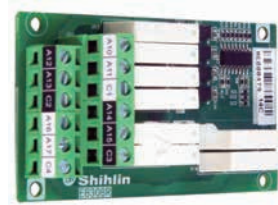

### EC301

EtherCAT communication expansion card



### PG301C (SE3/SA3 Only)

Encoder feedback card (supports open collector type output)



### PG301L (SE3/SA3 Only)

Encoder feedback card (supports differential type output)

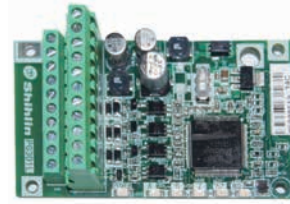

### PG302L (SE3/SA3 Only)

Encoder feedback card (supports Resolver signal)



### CMK301 (SE3 Only)

For installing expansion card on SE3



### Braking Unit(BKU)



# keypad

## Keypad

PU301(SC3/SE3/SA3/SF3)



PU301C(SA3/SF3)



PU302(SE3)



DU06(SS2/SC3)



DU10(SS2/SC3)



DU09S(SFG)





# SHIHLIN ELECTRIC & ENGINEERING

Transmission & Distribution, Electrical Products, Power Control, Switches & Breaker, Factory Automation, Automotive Electrical Components

## Factory Automation Overseas Sales Division

3F, No.9, Sec. 1, Chang-an E. Rd., Zhongshan Dist., Taipei City 10441, Taiwan

T. +886-2-2541-9822 F. +886-2-2581-2665

e-mail: [automation@seec.com.tw](mailto:automation@seec.com.tw)

<http://automation.seec.com.tw>

## Headquarters

16F, No.88, Sec. 6, Zhongshan N. Rd., Shilin Dist., Taipei City 11155, Taiwan

T. +886-2-2834-2662 F. +886-2-2836-6187

<http://www.seec.com.tw>

Distributor

B210223E.INV-BO3